



Unit II

Charging, Starting & Ignition System

By,
Mr. A J Bhosale
Asst. Professor
Dept. of Automobile Engineering
Govt. College of Engineering and Research, Avsari (Kd)



❖ Syllabus:

- Magnetos Constant current & voltage systems, Current & voltage regulator, Semi-conductor type regulator, Alternator with regulator, starting system with layout, selection of motor, matching battery, Drive mechanisms, Ignition coil, Distributor, Cam angle & Contact angle gap, Spark Advance mechanisms, Ballast Resistance, Limitations of coil ignition, Electronic Ignition system, Spark plugs, types, construction & characteristics.

❖ Requirements of the charging system

- Supply the current demands made by all loads.
- Supply whatever charge current the battery demands.
- Operate at idle speed.
- Supply constant voltage under all conditions.
- Have an efficient power-to-weight ratio.
- Be reliable, quiet, and have resistance to contamination.
- Require low maintenance.
- Provide an indication of correct operation.

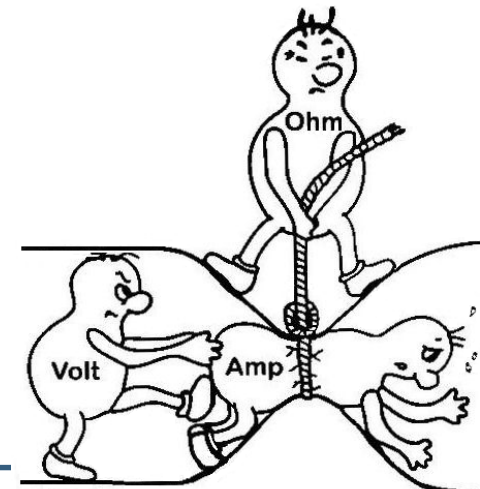

Methods of Generating Electric Current:

1. DC Generator (Dynamo and Magneto)
2. AC Generator (Alternator)

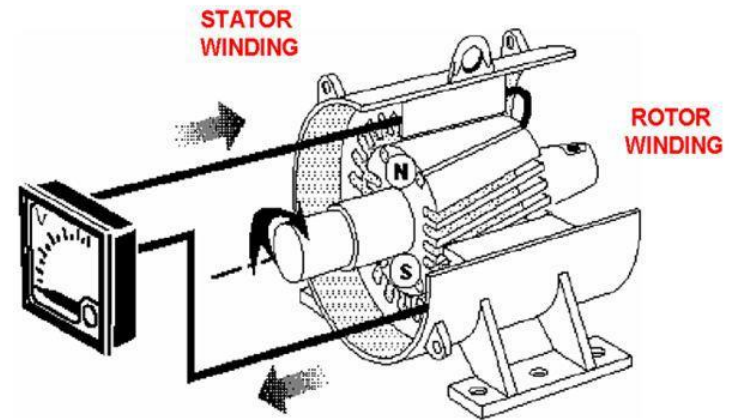
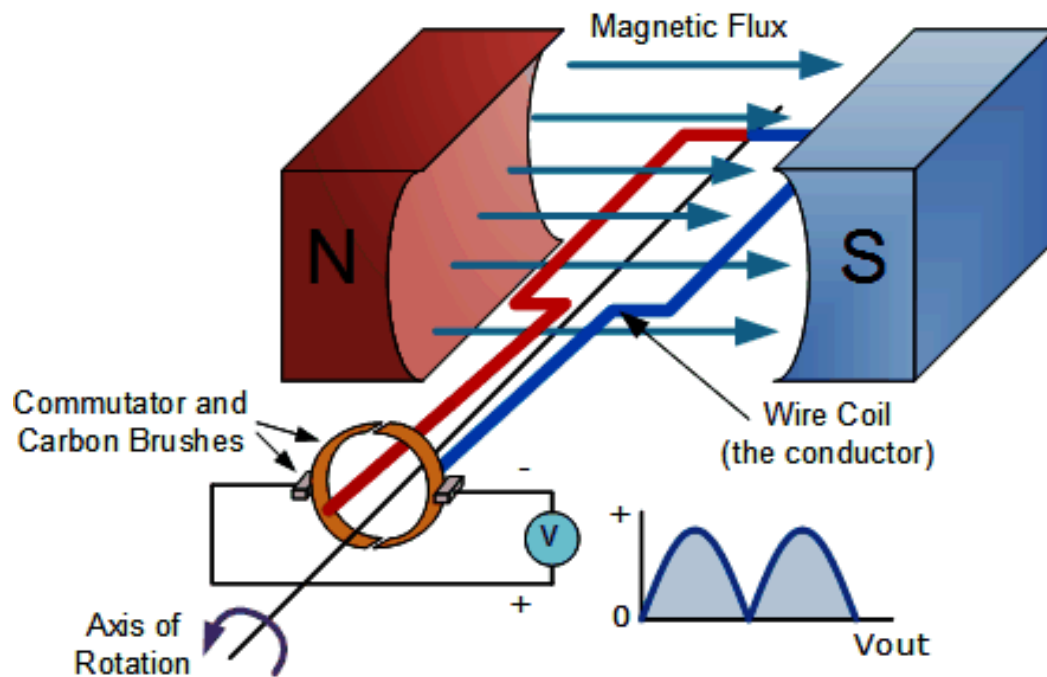

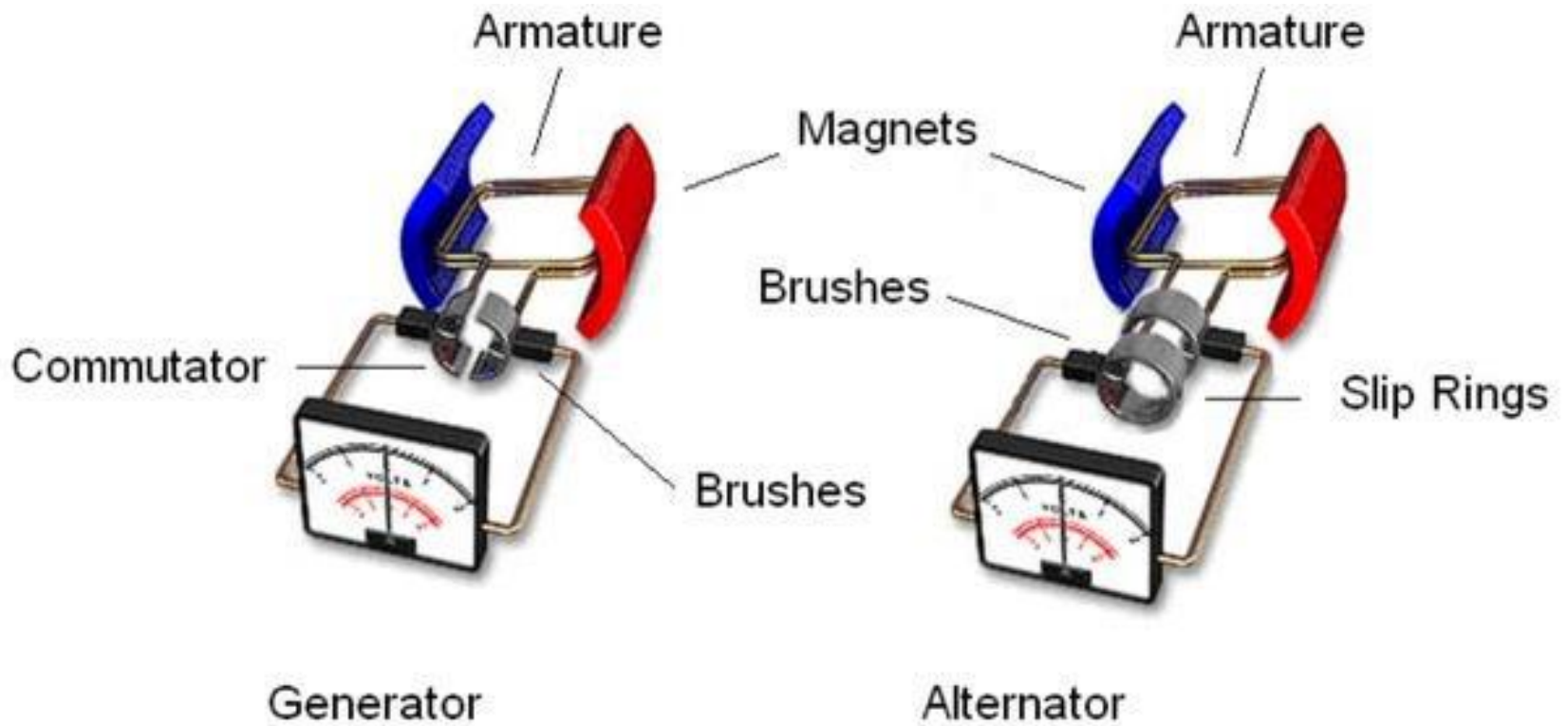

❖ Current and Voltage Regulator:

- To prevent the vehicle battery from being overcharged the regulated system voltage should be kept below the gassing voltage of the lead-acid battery. A figure of 14.2 ± 0.2 V is used for all 12 V charging systems.
- The output of an alternator without regulation would rise linearly in proportion with engine speed.
- Alternator output is also proportional to magnetic field strength and this, in turn, is proportional to the field current.
- Accurate voltage control is vital with the ever-increasing use of electronic systems. It has also enabled the wider use of sealed batteries, as the possibility of over-charging is minimal

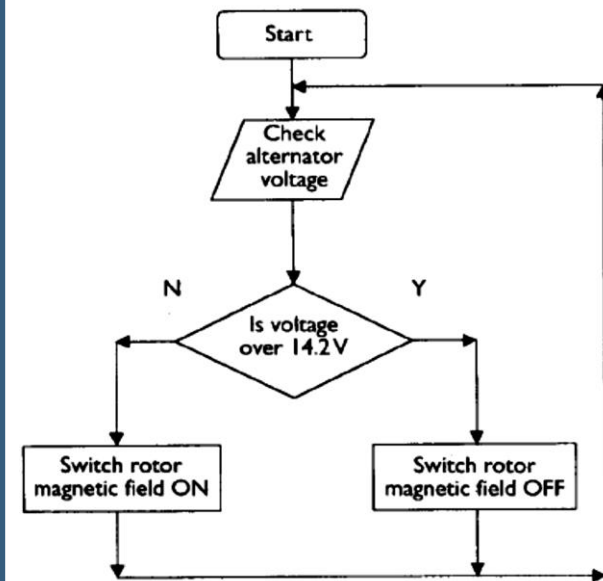



- A voltage regulator is an electromagnetic device. It operates in the same way as cutout relay.
- The voltage regulator prevents generation of excessive voltage, thus avoiding the damage to the electronic devices and overcharging of the battery.
- The current regulator limits the current and thus output of the generator is prevented from increasing beyond the rated output.
- The voltage produced depends on
 - The physical thing,
 - The speed of rotation
 - **The strength of magnetic field**

❖ Constant Current System:

- In this system, the shift of the magnetic field by armature reaction is made use of in controlling the output of generator.
- Referred as third brush regulation.
- In this the field windings are not connected across the two main brushes but instead they are connected across an auxiliary brush and one main brush.
- Figure shows the wiring circuit of the third brush generator.
- The third brush as shown is placed on leading side of main brush while main brushes are placed at correct positions on the commutator.

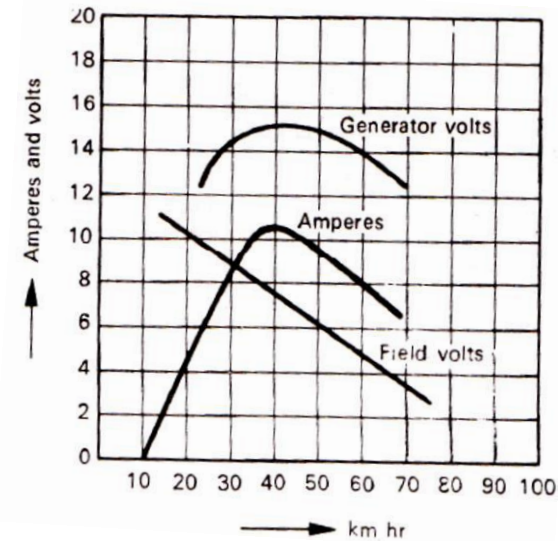

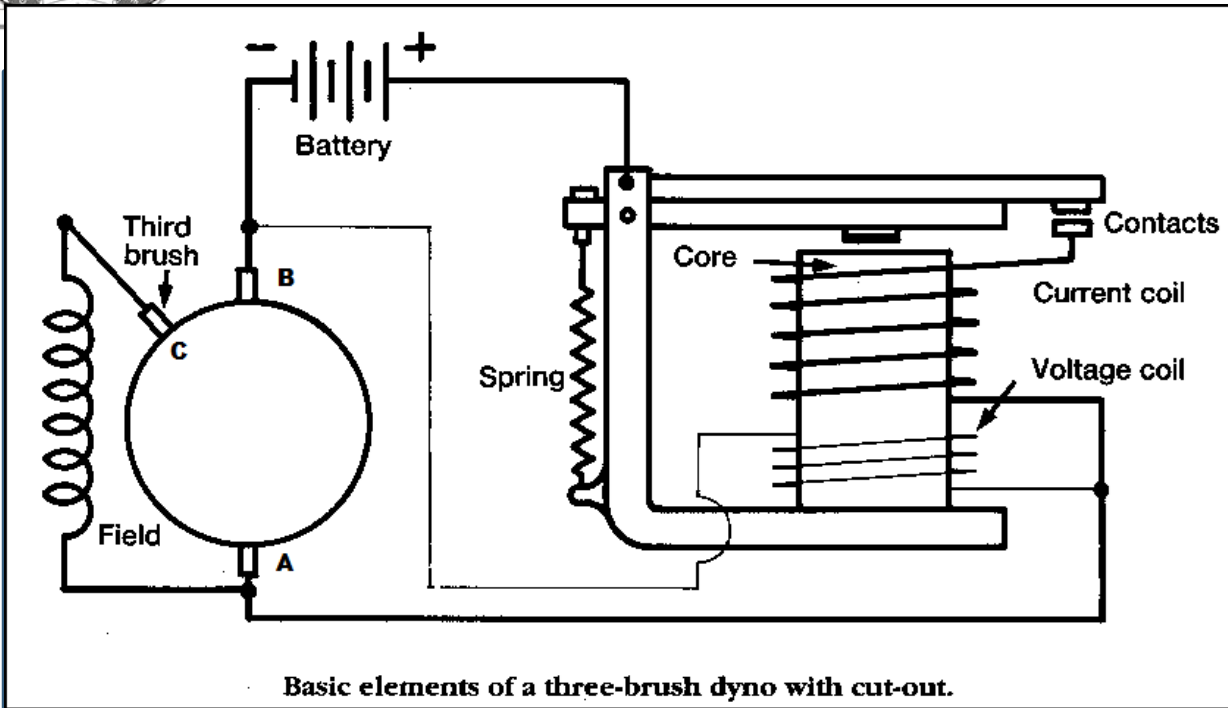
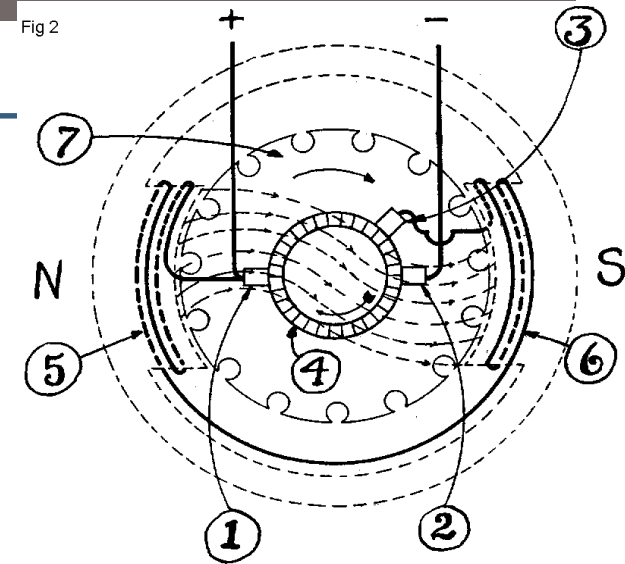

Fig 2



FUNCTIONS OF 3rd OR REGULATING BRUSH

Showing field coil connections for conventional 3rd brush regulated generator. No. 1—Main or positive brush; 2—Grounded or negative brush; 3—3rd or REGULATING brush; 4—Commutator; 5—Pole piece with field coil; 6—Pole piece with field coil; 7—Armature laminated core. Note how lines of magnetic force are distorted WITH direction of armature rotation at higher speeds. North and South poles are designated by N and S respectively.

- This arrangement ensures imposition of maximum voltage on the main brushes which is induced in the armature conductors.
- The voltage imposed on the field windings connected across brushes A and C is of lower value.



- The magnetic field produced because of current flow in the armature conductors increases in strength with an increase in generator speed and output.
- The increase in the strength of this field increases the distortion of the main field in the distortion of rotation.
- This distortion weakens the field under the leading tips of the pole shoes.
- This shifts part of the magnetic field past the third brush. This means that conductors between the third brush and the main brush are operating in weak field, resulting in lower induction of voltage in the field windings. This reduces the generator output.

- The maximum output of the generator is determined by the position of the third brush.
- When it has reached its, maximum, the magnetic field produced by the field windings becomes so weak that no further increase in generator output is possible.
- If the generator speed is further increased, it produces additional main field distortion and the generator output tapers off.
- By changing the position of the third-brush, the maximum o/p of the generator of this type can be adjusted.

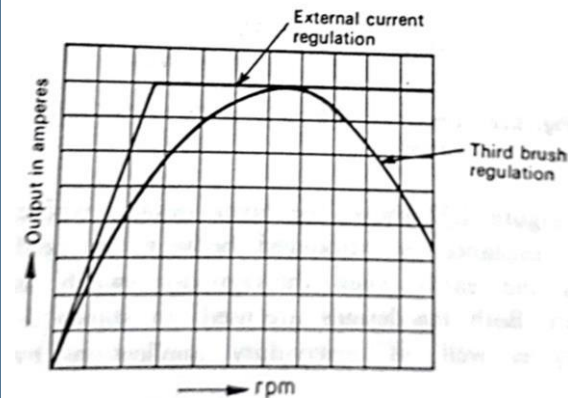

Fig. 4.25 Curves of the third-brush generator and external current generator regulation.



❖ **Constant Voltage System:**

- This method of regulation utilizes the principle of inserting resistance in series with field windings by some automatic means when the voltage of the generator reaches a certain value.
- It is used in cars of small, medium and large classes.
- As compared with the constant current system, this method of output regulation is controlled by generator voltage.
- In fact, the output of the generator in amps may vary to a considerable extent.
- Depending upon the conditions of lighting and of the starting system, it may be great or small.

- Fig. shows schematic of const. voltage system.
- A resistance in series is connected with the field winding which is short circuited when the contact points close under the pressure of the spring.
- The voltage regulator consists of an electromagnet wound with many turns of fine wire which is excited by the armature current.
- When the predetermined value of voltage is reached the vibrating bar attached with movable contact point is attracted by the magnet inserting resistance in the generator field circuit.

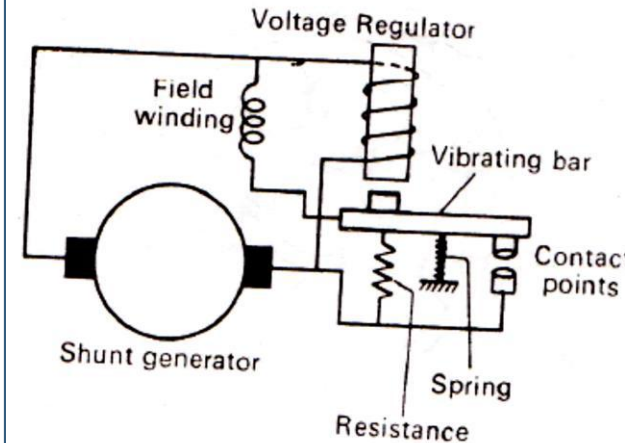



- This insertion of resistance in the field circuit increases the total resistance of field circuit, thus dropping the armature voltage allowing the spring to close the contact points.
- The closing of contacts will again increase the voltage and break the contacts.
- This sequence of operation is repeated and is continued rapidly as long as the generator is in operation.
- Thus, the generator voltage is automatically maintained between two relatively small limits.
- When the battery is connected to the generator, its voltage will increase until the predetermined voltage is reached.
- At this stage, the contacts of the regulator will start opening and closing to maintain the voltage.

- If the battery is in partially or totally discharged condition, the contact will stay closed for longer time and the rate of charge will be high.
- As soon as the battery voltage rises due to charging the opening and closing the contacts will take place and low charging current will be fed to battery.
- The movable contact frequency is proportional to the generator speed.
- Hence at low speed, the contacts will remain closed for longer period.
- The contact vibration are up to the extent of 70 per second normally but in some designs a more rapid rate is provided.
- The contacts are generally made of tungsten and in some cases, these may be made of pure silver.

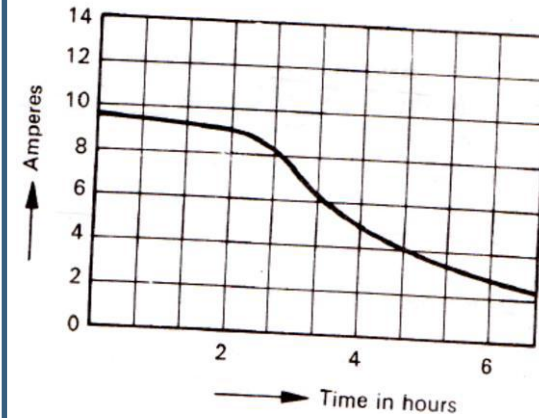



❖ **Comparison:**

❑ **Constant Voltage System:**

- It is efficient in operation and has definite limitation of voltage.
- It can operate without battery.
- Its charging rate is as per state of battery and responds to increase in load.

❑ **Constant Current System:**

- It is less costly to manufacture.
- It is simple in design and construction and quiet reliable.
- It has minimum number of components which require adjustments



❖ **Limitations of Third Brush Regulation:**

- In the case of this system of regulating the o/p of the generator, the battery state of charge has a prominent effect.
- The generator having this system of regulation will supply more current to a fully charged battery than to a discharged battery.
- It is because a fully charged battery will have a higher terminal voltage, thus providing a higher voltage to the field winding of the generator.
- It causes an increase in the generator field strength and ultimately leads to arise in voltage and output of the generator
- The discharged battery, similarly will result in a lower o/p of the generator.
- This is certainly an undesirable thing, keeping in view the electrical requirements of automobiles. It is ,therefore, essential to have some other means of regulating the generator output in addition to this method.



- Figure shows third brush generator with thermostatic controlled field resistance.
- In case of a cold generator, the contact points remained closed, thus directly grounding the field for full o/p of the generator.
- When the generator became hot during operation, the contacts points got opened by the thermostatic blade, thereby inserting the resistance in the field circuit.
- This resulted in the reduction of the field current and hence that of the o/p of the generator.
- This how thermostatic control was used for protecting the generator from damage due to overheating.

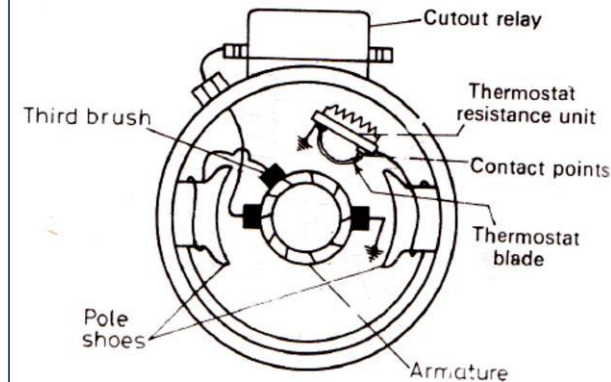
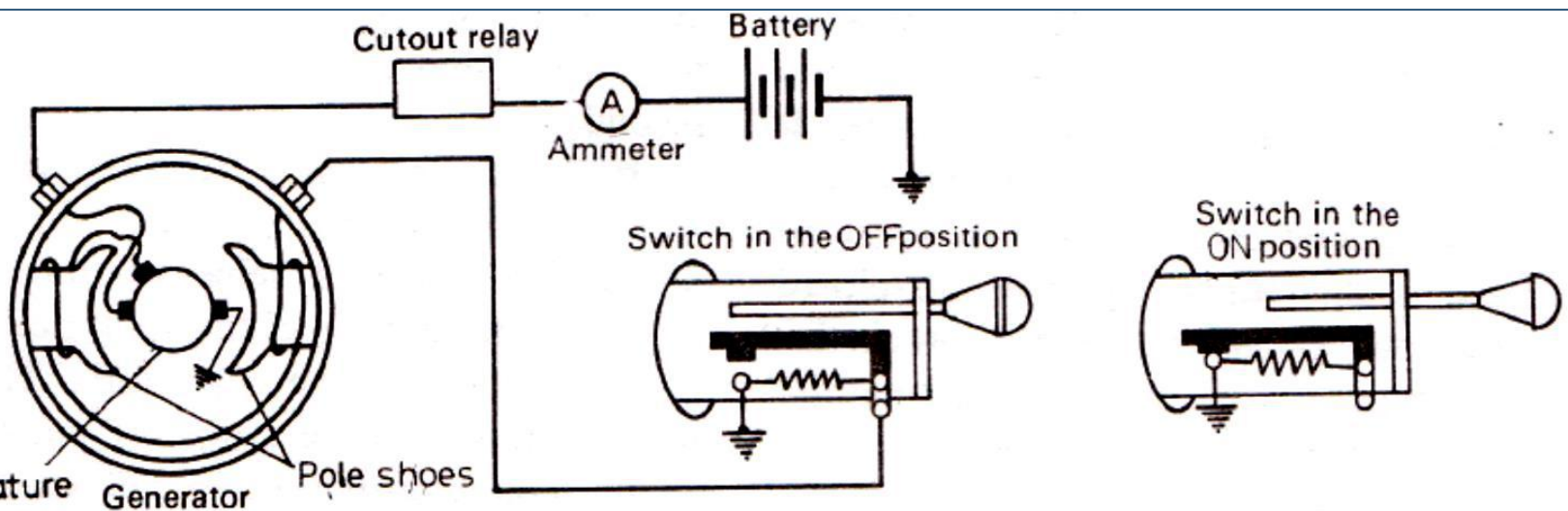

Fig. 5.4 Third-brush generator with thermostatically controlled field resistance

- On some generators, drivers were controlling the field resistance, the driver could insert or short out the resistance depending upon the condition of the battery.
- One drawback of this system was that the driver often did not understand what he was expected to or else he forget to operate the switch.
- An improvement was made over this system by inserting the resistance in the light switch. The resistance was introduced in the field circuit when the light switch was off which in turn reduced the o/p of generator.
- As the light switch was turned on, the resistance was shorted out thereby allowing the generator to produce higher o/p



- The schematic wiring diagram shows step voltage control unit.
- This device operated on the circuit voltage in two steps. Increase in the circuit voltage increased the magnetism in the winding till it was sufficient to pull the armature towards it.
- When this happened, it inserted the resistance in the field circuit by opening the contact points.
- This resulted in a reduced output of the generator till such time as the battery became partly discharged.

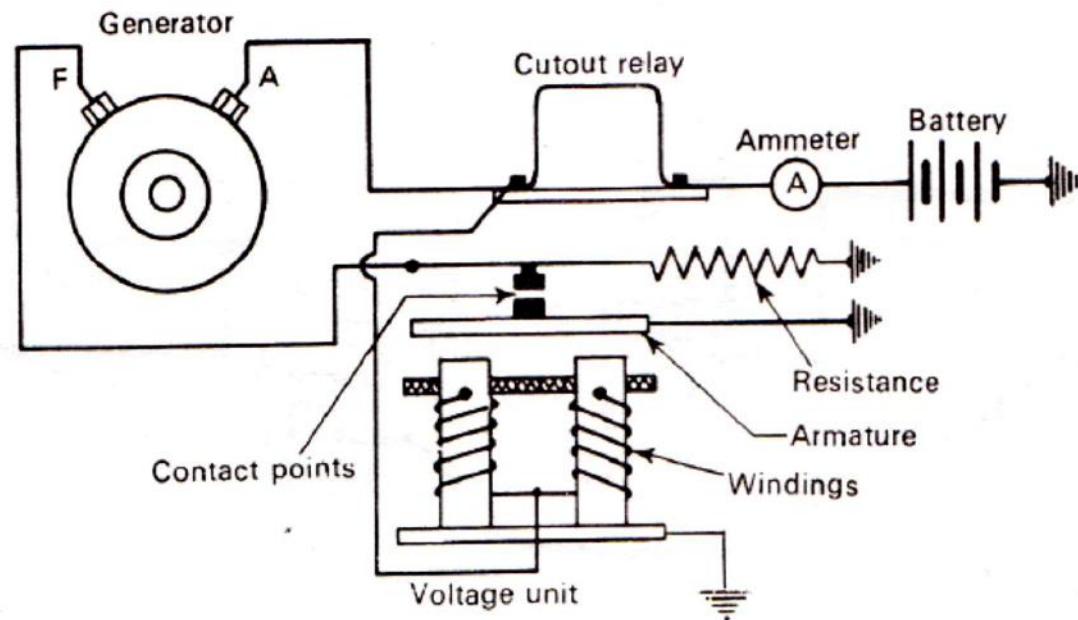
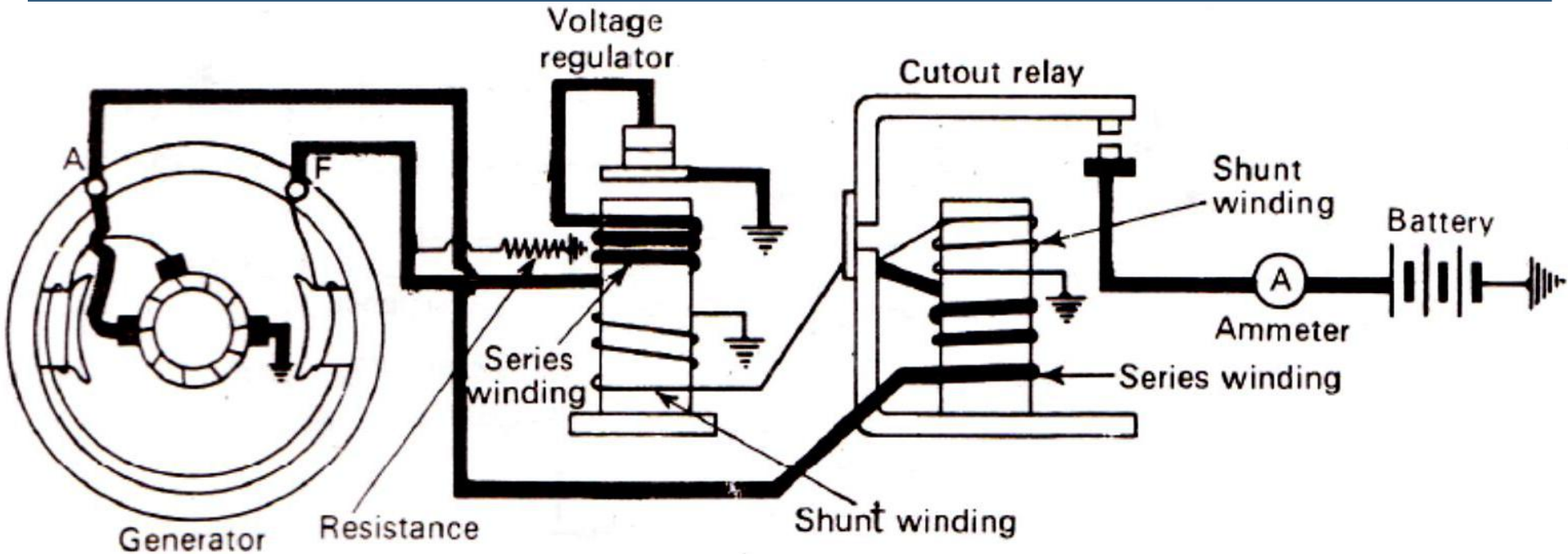

Fig. 5.6 Wiring diagram of the step voltage control unit and cutout relay.



- When the circuit voltage fell enough so that the pull of the spring overcame the magnetic pull, the points again closed, thereby allowing the generator o/p to increase.
- This method of controlling the o/p provided only two steps of control and hence it was not very satisfactory under different operating conditions.
- This lead to the use of a vibrating voltage regulator which suited different operating conditions
- This method prevents the generator voltage form exceeding a certain predetermined safe value.

- Fig. shows the schematic of the vibrating voltage regulator used with the third brush generator for controlling its o/p under varying operating conditions. With this method, almost const. voltage is maintained in system.
- The voltage regulator and the cutout relay are mounted on the same base and enclosed by the same cover.





- There are two windings on the voltage regulator core, namely, shunt winding and series winding. The shunt winding is of fine wire, whereas the series winding is of heavy wire.
- The shunt winding is connected across the generator and hence the generator voltage is impressed upon it.
- The series winding is connected in series with the field winding and carries direct field current to earth when the contact points are closed.
- The lower contact point is movable and earthed all the time, whereas the upper contact point is stationary and insulated.
- This point is connected to the regulator series winding. The contact points are held together when the battery is low and high generator o/ is required.
- The o/p of the generator is decided by the generator speed and the setting of the third brush.



- When the battery approaches the charged condition, the voltage increases.
- This in turn increases the magnetic pull in the shunt winding of the regulator.
- This increase in pull separates the contact points by pulling the armature towards the core after overcoming its spring tension.
- This action inserts the resistance in the field circuit, causing the o/p of the generator to fall. The fall in voltage decreases the magnetic pull and the spring tension again closes the points, thereby directly grounding the field.
- This once again increases the voltage and o/p of the generator.
- It causes the voltage to reach a predetermined maximum value and the shunt winding of the regulator pulls the armature towards the core, thus separating the points once more.
- This sequence of opening and closing the points is very rapid.(200 times a second)



- It should be noted that the series winding, which carries the field current when the points are closed, is only helper winding.
- It produces a small percentage of the total pull and speed up the action of the armature.
- The magnetic field of this winding collapses entirely as soon as the points open because the winding is open-circuited. Hence the magnetic strength of the winding core is reduced this quickly accomplishes the closing of the points.

- The constant voltage type has one disadvantage, it needs a large o/p generator for its satisfactory operation.
- If a battery is in discharged condition and the electrical load is switched on, the voltage will fall further.
- For the regulator to maintain its set voltage, very heavy current will flow through the armature coils and the battery, thus posing a danger of burning the armature coils.
- The compensated type of regulator overcomes this drawback.

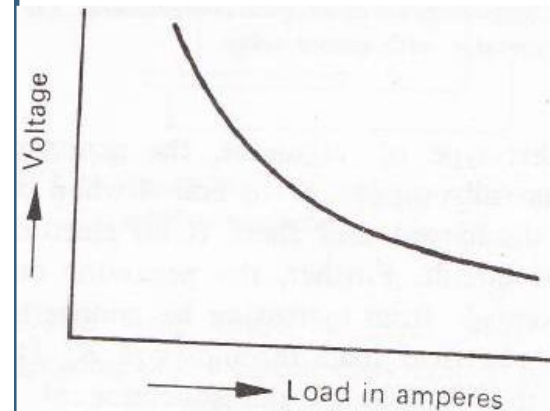

❖ Compensated voltage regulator

- The core of the regulator is provided with three windings, namely, series coils A and B and voltage coil C.
- Coil A is placed in the external circuit of the generator and coil B in the lead from the battery to the electrical equipments of the vehicle.
- The combined effect of these three coils governs the movement of the hinged armature in such way that it gives the desired regulator action under different speed, load and battery conditions.

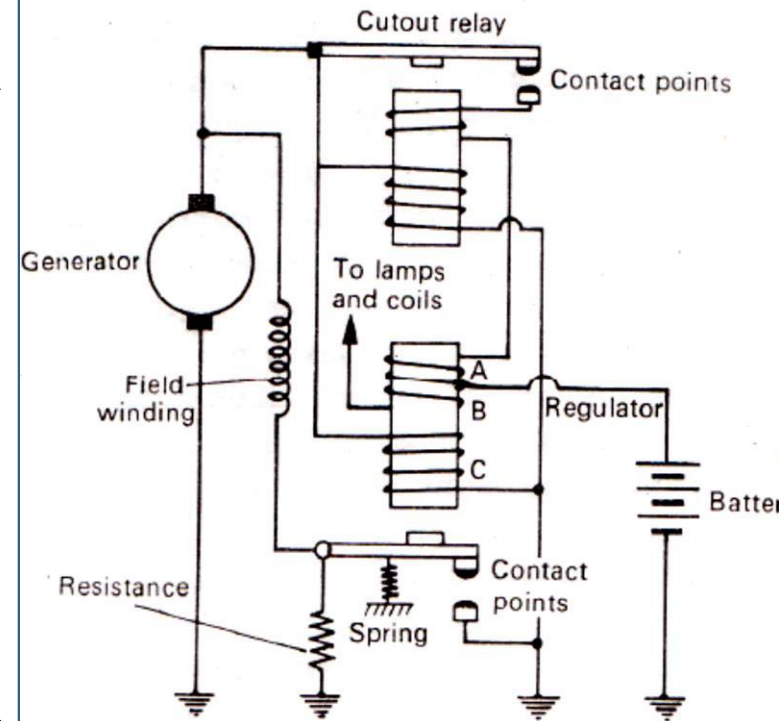

Fig. 5.10 Circuit diagram of a typical compensated voltage regulator with cutout relay.



- With this type of regulator, the generator develops its full o/p due to coil A when the battery is discharged and there is no electrical load in the circuit.
- Further the generator o/p is prevented from increasing by connecting the main electrical load through coil B. This maintains the o/p of the generator at its full, quite independent of the electrical load.

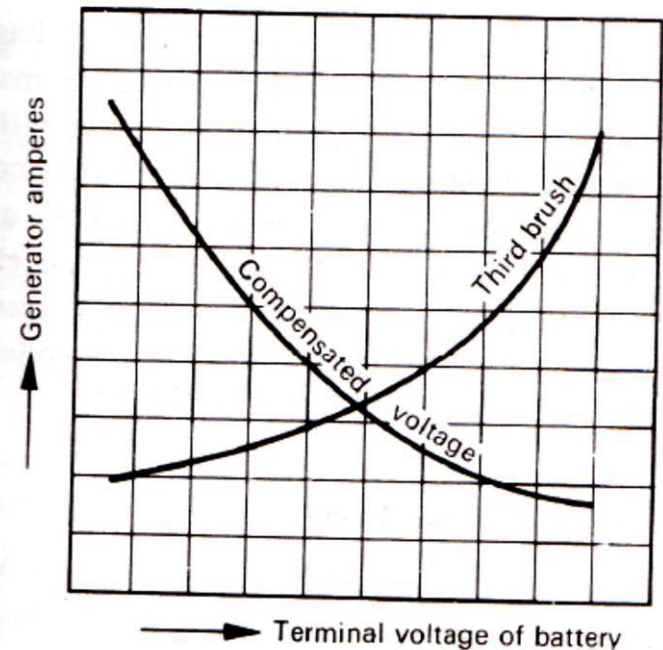
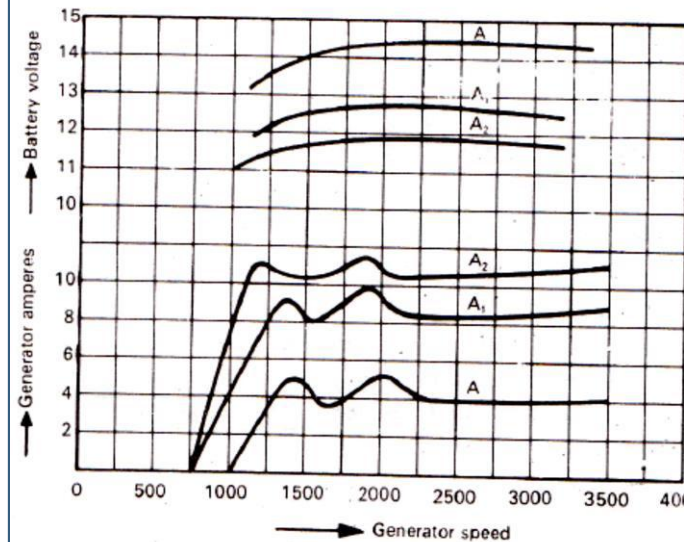

Fig. 5.12 Comparison of third-brush and compensated voltage system.

- Fig. shows the curves of battery voltage and generator current reflective the performance of the compensated voltage control system.
- A, A₁ and A₂ corresponds to fully charged, almost discharged and fully discharged battery.
- When the battery is fully charged, the generator supplies only a small amount of charge.
- The charging rate increases as the battery is in lower state of charge (A₁ and A₂ Curves)
- Hence the charging is automatically adjusted as per the state of battery conditions.





❖ **Current and Voltage Regulator**

- This system of control is different from the compensated voltage control system. In this system two independent regulators are used for controlling the current and voltage.
- The winding of one regulator is used to control the generator o/p current, while that of other is used to control the voltage of generator.
- The net effect of using both the current and the voltage control systems is that both the current and voltage values of the generator are controlled to suit the electrical loadings and the conditions of battery.

- The characteristics of the two systems of control under the same operating conditions.
- It can be observed that, with the current and voltage regul. System a constant charging current is fed into the battery till a pre-set value of voltage is reached.
- At this point the voltage regulator takes over and gradually reduces the charging current until the conditions of drop charge are obtained.
- The charging current falls steadily from the beginning of the compensated voltage system.

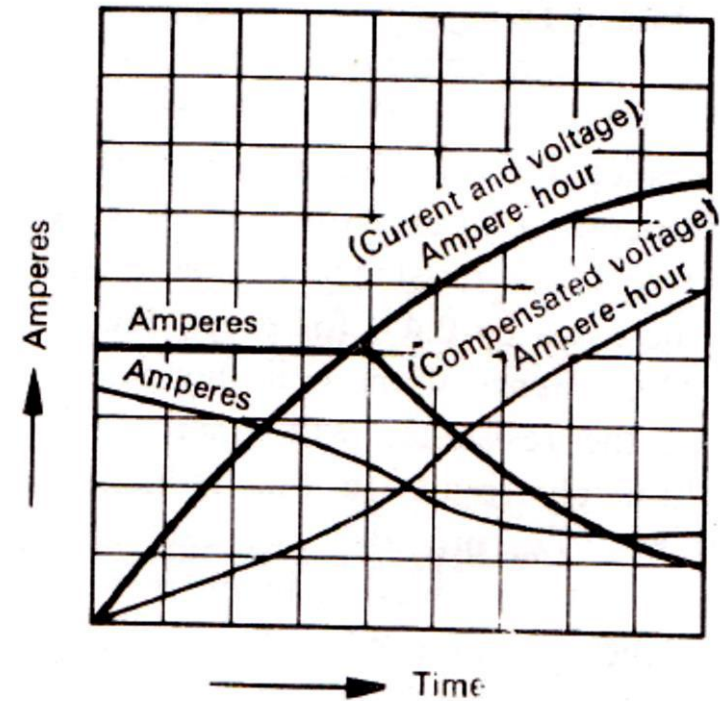



- It is also evident from fig. that in the case of the current and voltage system, the ampere-hour input to the battery in a given time is much greater when compared with the compensated voltage system.
- The current and voltage control system provides much closer control of the generator o/p. The short circuited battery cell, short circuited wiring, or excessive lamp load do not overload the generator.
- The fig. shows the circuit diagram for a current and voltage control regulator system together with the cutout relay mounted on the same base having certain common leads.
- It should be noted that the cut out relay is entirely independent unit and it does not affect the operation of the regulator.



- The current regulator is wound with a few turns of a heavy gauge wire because it is subjected to full current o/p of the generator.
- The voltage regulator is wound with larger number of fine wire turns as it carries only a small value of current. Two resistances are provided, one each for the voltage and current regulators.
- When the speed of the generator is increased from idle state, the contacts of the cutout relay close, allowing the current o/p of the generator to flow through the closed contacts of the cutout relay and also through the winding and also through the current regulator winding.

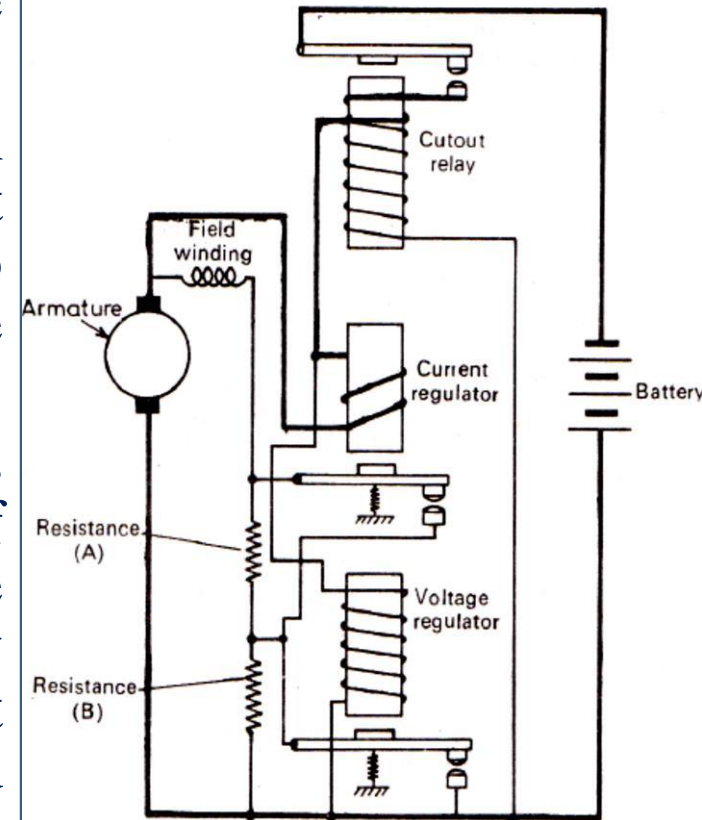

Current and Voltage regulator



- When the current reaches its predetermined value, the contacts of the current regulator separate, thus inserting resistance A in the generator field circuit.
- It reduces the current o/p the generator, thereby reducing the pull on the current regulator armature. The spring again closes the contacts allowing the current o/p of the generator to increase.
- Whenever the voltage attains its predetermined maximum value, the voltage regulator is sufficiently energized to open the voltage regulator contacts. Thus inserting the resistance B, resulting in the reduction of the current o/p of the generator. The spring again closes the contacts allowing the current o/p of the generator to increase.

❖ Semi-conductor type Regulator:

- This type of regulator has been developed by Bosch and has been more recently employed on automobiles. It is known as pn-junction.
- The characteristic curve of this regulator is similar to that of the current and voltage regulator but it has no current control member.
- It consists of **germanium doped with indium or antimony**. The principle of this unit is that when antimony is used, an excess of negative charge is produced and it produces an excess of positive charge when indium alloy is used.
- The essential element of this regulator is the junction of the n-type and p-type materials.

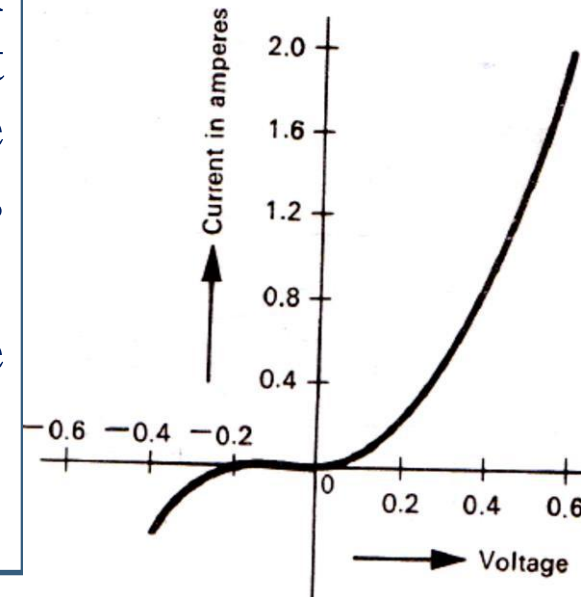
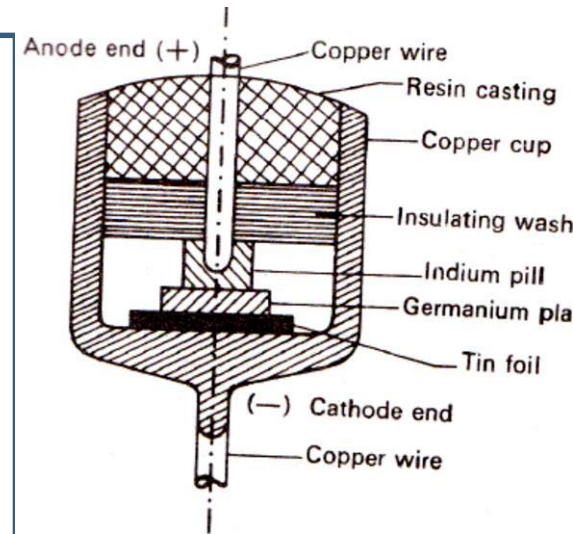



- The regulator permits only a weak current to flow through it when it is subjected to a low voltage current in the forward direction; but the current is increased at a much more rapid rate as the voltage is increased.
- Fig. shows the wiring diagram for a variode type of regulator along with the cutout relay.
- It operates in the same manner as the compensated voltage regulator, giving the same type of a drooping voltage characteristic curve.
- It can be seen that a weaker conductor is connected in parallel with main current conductor, that is from +D through the cutout relay current winding leading to the variode element to the control winding on the regulator element and receiving the voltage drop that takes place in the main current conductor because of the resistance.

- When the generator loads are low, the voltage drop is very low and only a very weak current passes through variode.
- When the pre-determined voltage drop is attained corresponding to a given generator load, a considerable rise in current takes place in the control winding.
- The main current conductor resistance is selected in such a manner that the full action of the variode takes place at the maximum permissible current.

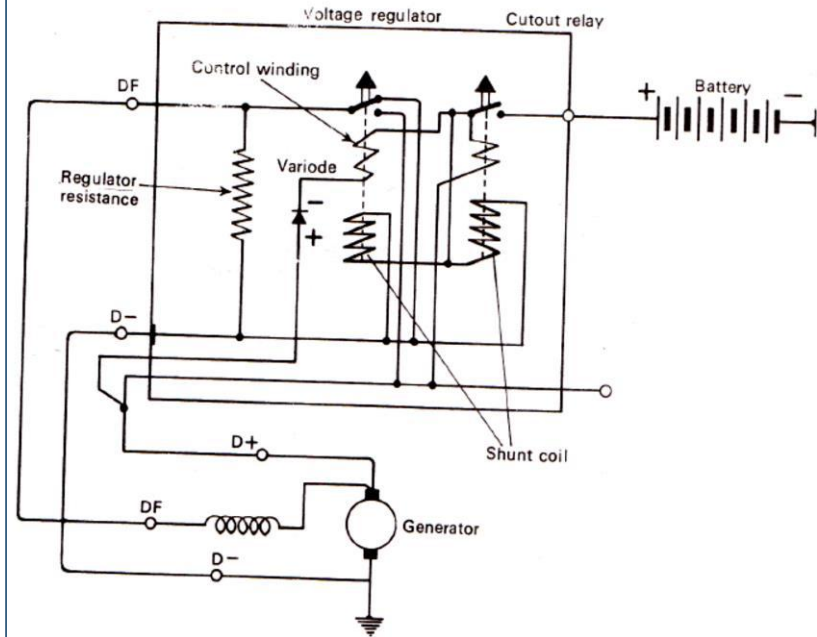

- A rapid decrease in the generator voltage takes place due to the magnetic field generated by the control winding, thus protecting the generator against overloading.
- In the case of the ordinary voltage regulator, a temperature compensation device is provided to accommodate the effects of the temperature changes.
- This is distinct advantage of the variode, that the current intensity at which the voltage is reduced on the cold regulator is much above the peak value allowed for the generator.
- However, it does not affect the cold generator in an adverse manner. When the temperature of the regulator and generator rises, the current is limited to the allowable safe value.
- Hence the provision of the variode in the regulator allows the generator to be better utilized under heavy load conditions such as city driving with frequent stops and low speeds allowing the battery to be kept in the well charged condition.

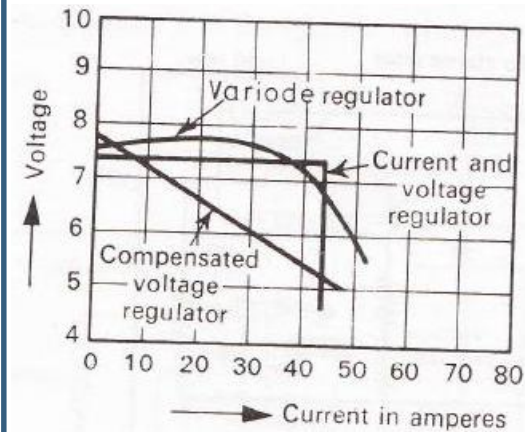



❖ **Alternators:**

- With increase in installation of electrical equipment in present day vehicles, the demand on direct current generator has increased.
- This can only be met by increasing the size and weight of the generator and also by running it at higher speeds.
- Because of brush and commutator limitations, the DC generator speed can not be increased beyond a certain limit.
- Hence, it has become necessary to employ alternators in certain cases.

❖ Advantages of Alternators over DC generators:

- About 30% higher speeds can be achieved when compared with a dc generator whose operating speed is restricted to 9000 rpm. Alternators can run safely at about $2\frac{1}{2}$ times the engine speed, whereas a dc generator is limited to about $1\frac{3}{4}$ times the engine speed.
- Has higher power to weight ratio.
- Does not require maintenance attention because of light slip rings.
- Simple in design and robust design when compared with dc generator.
- High o/p at low engine speed can be obtained.
- Cutout relay is not necessary because rectifiers does not allow reverse current to pass to alternator.
- The alternators can be made to provide self-regulation due to its winding reactance.

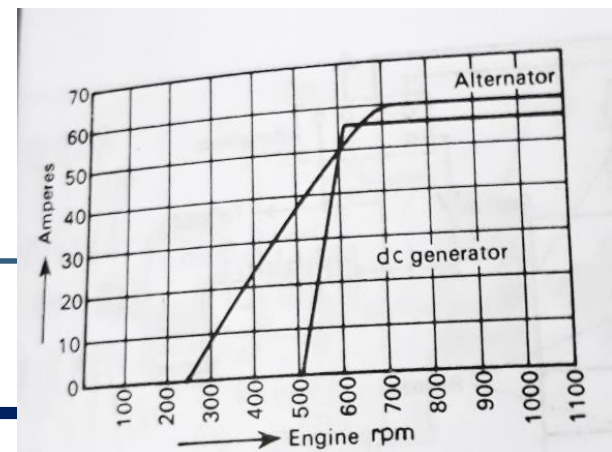



❖ Regulators for Alternators:

- Regulators for alternators operate in the same manner as regulators for generators. The regulation is achieved in both system by varying the amount of resistance in the field circuit of the alternator/generator.
- It is not essential to employ an external device for limiting the current in order to control the o/p of the alternator.
- The reactance of the alternator is such that the current is limited to 65 A when cold and to 57 A when hot at all speeds up to 11000 rpm.
- In a recent years, a good variety of regulators for alternators have been developed and some of them look like the regulators used for generators and are operated and adjusted in the same way.

- There are some regulators which have no cutout relays since the rectifying diodes prevent the flow of reverse current.
- There are still others which make use of transistors. The transistors work with the vibrating contact points to control the alternator field current and the o/p.
- There is another variety which has no moving parts at all. They make use of transistor only for control.

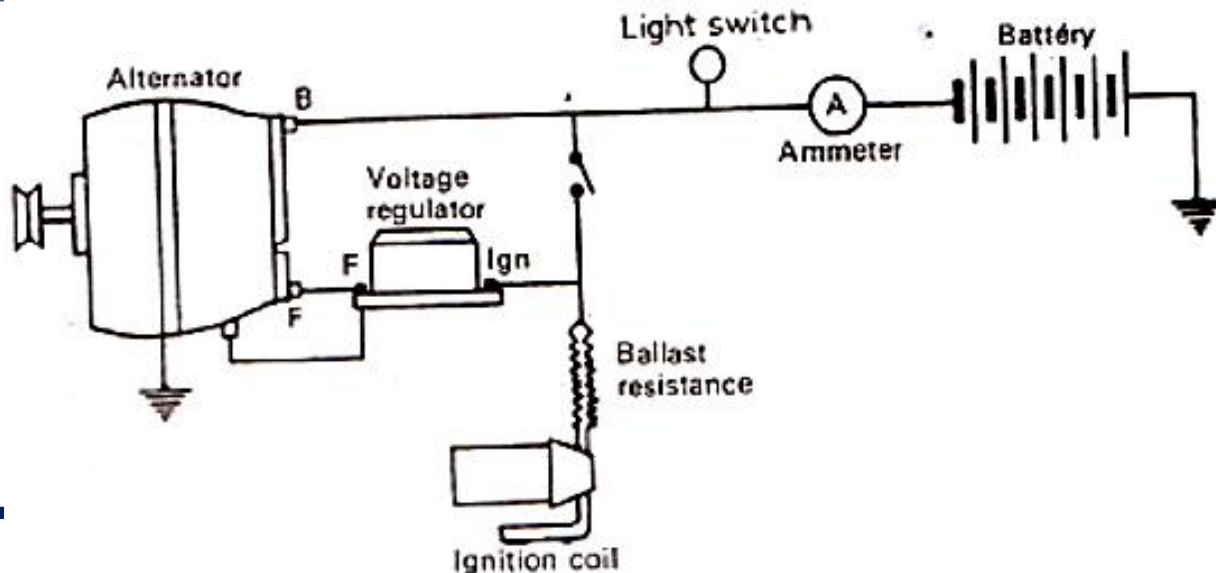



Torque Terms:

1. Engine Breakaway Torque

- It is the torque required to start moving engine crankshaft from the rest position.

2. Engine Resisting Torque

- Once the engine has started moving, the torque required to keep it moving is termed as resisting torque. It is about one half of that of the breakaway torque.



3. Motor Locked Torque

- It is the torque developed immediately the battery current is switched on, so that the armature starts rotating from the rest position. It is more than the engine breakaway torque, since it has to commence rotating the crankshaft.

4. Motor Driving Torque:

- It is the torque of the motor when the armature shaft pinion gear is driving the flywheel gearing. It is greater than that of the engine resisting torque.

❖ Starting System:

- An internal combustion engine requires the following criteria in order to start and continue running.
 - Combustible mixture.
 - Compression stroke.
 - A form of ignition.
 - The minimum starting speed (about 100 rev/min).
- In order to produce the first three of these, the minimum starting speed must be achieved. This is where the electric starter comes in.

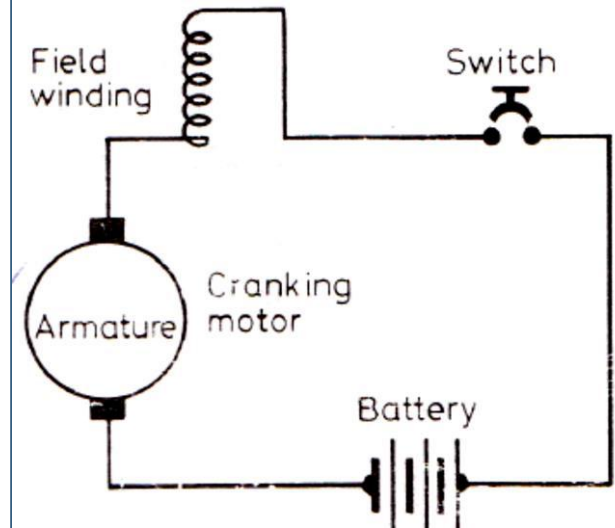



- The ability to reach this minimum speed is again dependent on a number of factors.
 - Rated voltage of the starting system.
 - Lowest possible temperature at which it must still be possible to start the engine. This is known as the starting limit temperature.
 - Engine cranking resistance. In other words the torque required to crank the engine at its starting limit temperature (including the initial stalled torque).
 - Battery characteristics.
 - Voltage drop between the battery and the starter.
 - Starter-to-ring gear ratio.
 - Characteristics of the starter.
 - Minimum cranking speed of the engine at the starting limit temperature.

- Figure shows effect of temperature on starting torque and cranking speed, as temperature decreases, starter torque also decreases and the torque required to crank the engine to its minimum speed increases.
- Typical starting limit temperatures are $-18\text{ }^{\circ}\text{C}$ to $-25\text{ }^{\circ}\text{C}$ for passenger cars and $-15\text{ }^{\circ}\text{C}$ to $-20\text{ }^{\circ}\text{C}$ for trucks and buses. Figures from starter manufacturers are normally quoted at both $+20\text{ }^{\circ}\text{C}$ and $-20\text{ }^{\circ}\text{C}$.

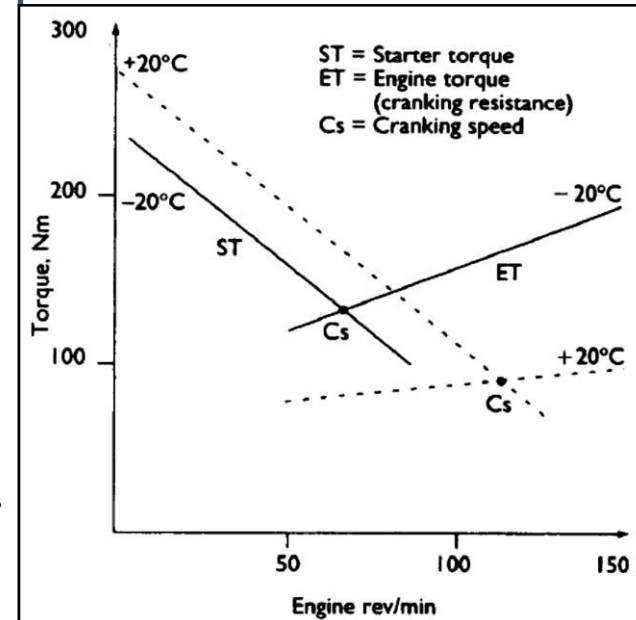

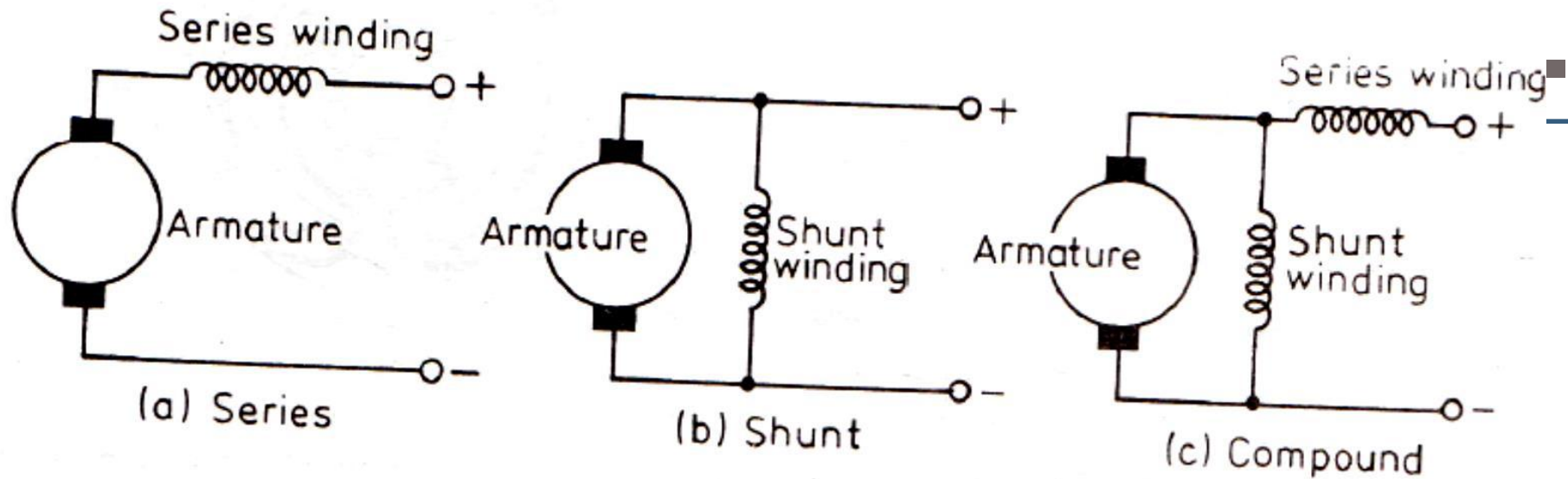

Fig. 6.7 Types of cranking motors.

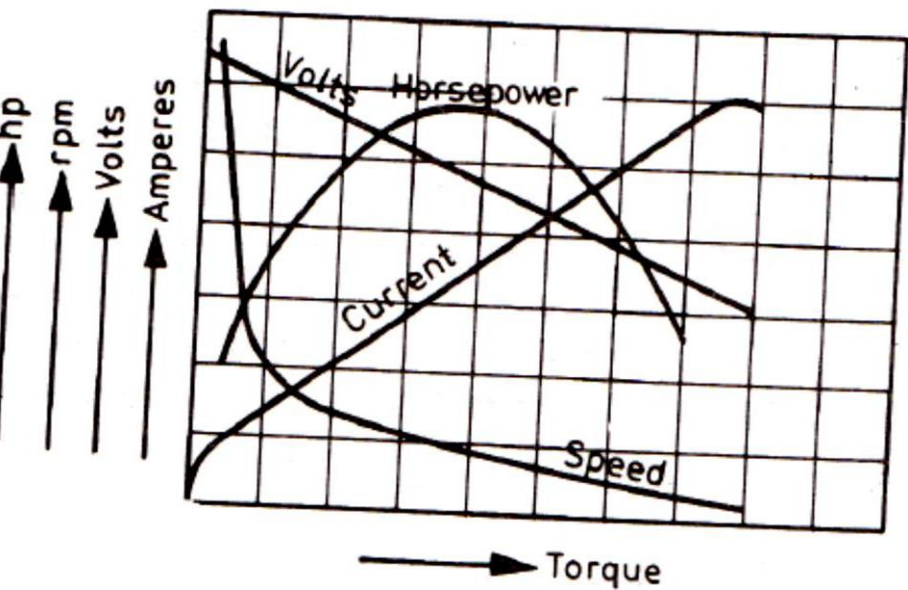

Fig. 6.8 Characteristic curves of cranking motors.

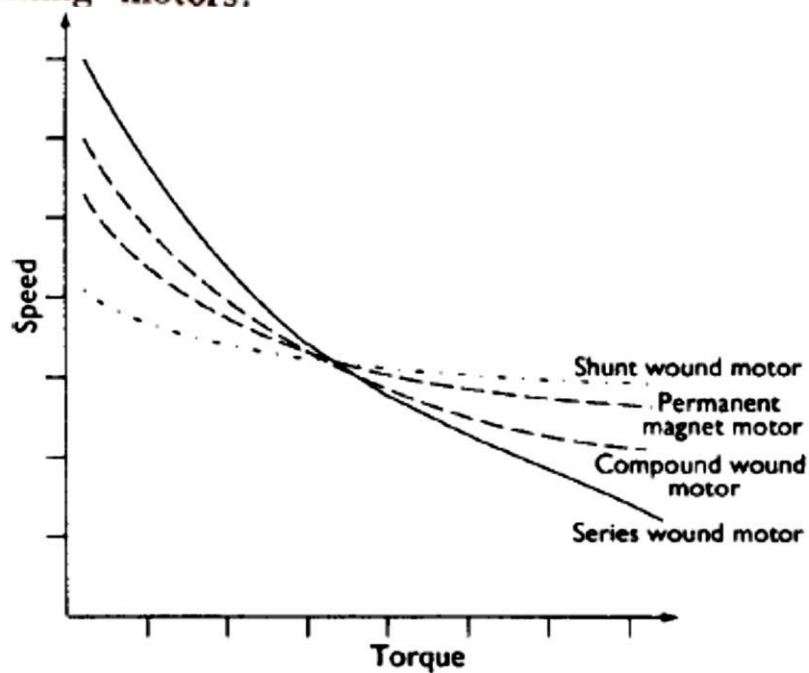

Figure 7.12 Speed and torque characteristics of DC motors

❖ Starting system design

- The starting system of any vehicle must meet a number of criteria in excess of the eight listed above.
- Long service life and maintenance free.
- Continuous readiness to operate.
- Robust, such as to withstand starting forces, vibration, corrosion and temperature cycles.
- Lowest possible size and weight

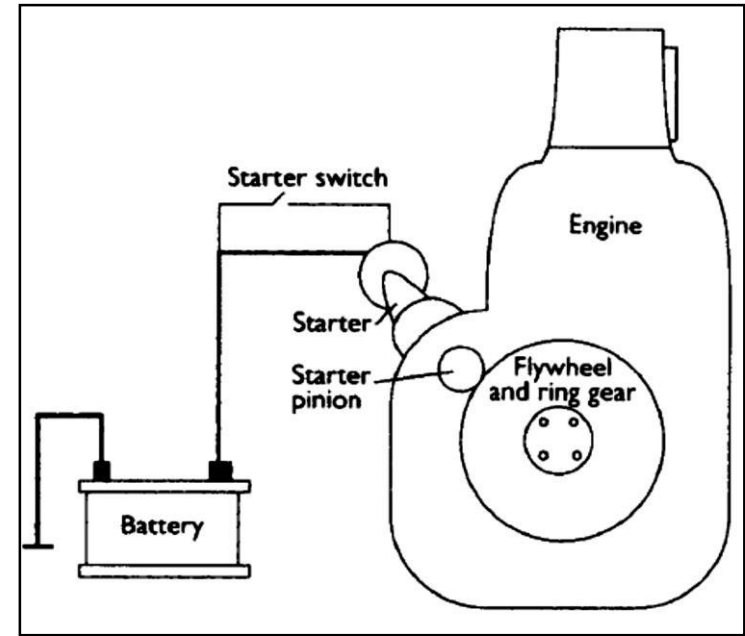

Table 7.1 Typical minimum cranking speeds
(For -20 °C)

Engine	Minimum cranking speed (rev/min)
Reciprocating spark ignition	60–90
Rotary spark ignition	150–180
Diesel with glow plugs	60–140
Diesel without glow plugs	100–200



- It is important to determine the minimum cranking speed for the particular engine. This varies considerably with the design and type of engine. Some typical values are given in Table 7.1 for a temperature of -20°C .
- The rated voltage of the system for passenger cars is, almost without exception, 12V. Trucks and buses are generally 24 V as this allows the use of half the current that would be required with a 12V system to produce the same power.
- It will also considerably reduce the voltage drop in the wiring, as the length of wires used on commercial vehicles is often greater than passenger cars.
- The rated output of a starter motor can be determined on a test bench. A battery of maximum capacity for the starter, which has a 20% drop in capacity at -20°C , is connected to the starter by a cable with a resistance of $1\text{m}\Omega$.



- These criteria will ensure the starter is able to operate even under the most adverse conditions.
- The actual output of the starter can now be measured under typical operating conditions.
- The **rated power** of the motor corresponds to the power drawn from the battery less copper losses (due to the resistance of the circuit), iron losses (due to eddy currents being induced in the iron parts of the motor) and friction losses.
- There are two other considerations when designing a starting system. The location of the starter on the engine is usually pre-determined, but the position of the battery must be considered.

- Other constraints may determine this, but if the battery is closer to the starter the cables will be shorter.
- A longer run will mean cables with a greater cross-section are needed to ensure a low resistance.
- Depending on the intended use of the vehicle, special sealing arrangements on the starter may be necessary to prevent the ingress of contaminants.
- Figure shows an equivalent circuit for a starter and battery. This indicates how the starter output is very much determined by line resistance and battery internal resistance. **The lower the total resistance, the higher the output from the starter.**

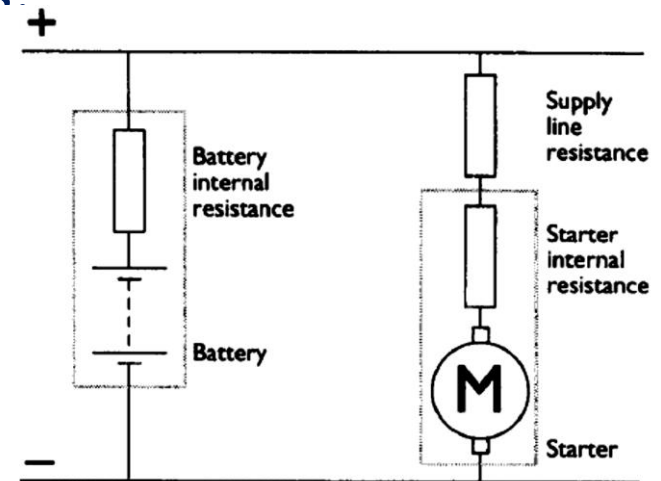

❖ Starting Motor Selection:

- As a guide, the starter motor must meet all the criteria previously discussed.
- Referring back to Figure (the data showing engine cranking torque compared with minimum cranking speed) will determine the torque required from the starter.
- Manufacturers of starter motors provide data in the form of characteristic curves.
- The data will show the torque, speed, power and current consumption of the starter at +20 °C and -20 °C. The power rating of the motor is quoted as the maximum output at -20 °C using the recommended battery.
- Figure shows how the required power output of the starter relates to the engine size.

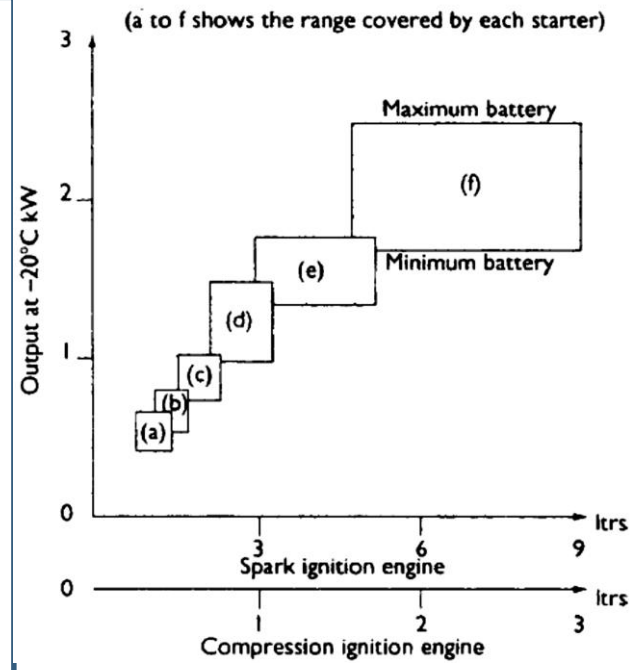

Table 7.2 Torque required for various engine size

Engine cylinders	Torque per litre [Nm]
2	12.5
4	8.0
6	6.5
8	6.0
12	5.5



- As a very general guide the stalled (locked) starter torque required per litre of engine capacity at the starting limit temperature is as shown in Table 7.2.
- A greater torque is required for engines with a lower number of cylinders due to the greater piston displacement per cylinder. This will determine the peak torque values. The other main factor is compression ratio.
- **To illustrate the link between torque and power, we can assume that, under the worst conditions (-20 °C), a four-cylinder 2-litre engine requires 480 Nm to overcome static friction and 160 Nm to maintain the minimum cranking speed of 100 rev/ min.**
- **With a starter pinion-to-ring gear ratio of 10 : 1, the motor must therefore, be able to produce a maximum stalled torque of 48 Nm and a driving torque of 16 Nm.** This is working on the assumption that stalled torque is generally three to four times the cranking torque.



- Torque is converted to power as follows:

$$P = T\omega$$

where P = power, T = torque and ω = angular velocity.

$$\omega = \frac{2\pi n}{60}$$

where n = rev/min.

- In this example, the **power developed at 1000 rev/min** with a torque of **16 Nm (at the starter)** is about **1680W**.
- Referring back to Figure, the ideal choice would appear to be the starter marked (e).
- The recommended battery would be **55 Ah** and **255 A cold start performance**

- This graph shows how the speed of the motor varies with load.
- Owing to the very high speeds developed under no load conditions, it is possible to damage this type of motor.
- Running off load due to the high centrifugal forces on the armature may cause the windings to be destroyed.
- Note that the maximum power of this motor is developed at midrange speed but maximum torque is at zero speed.

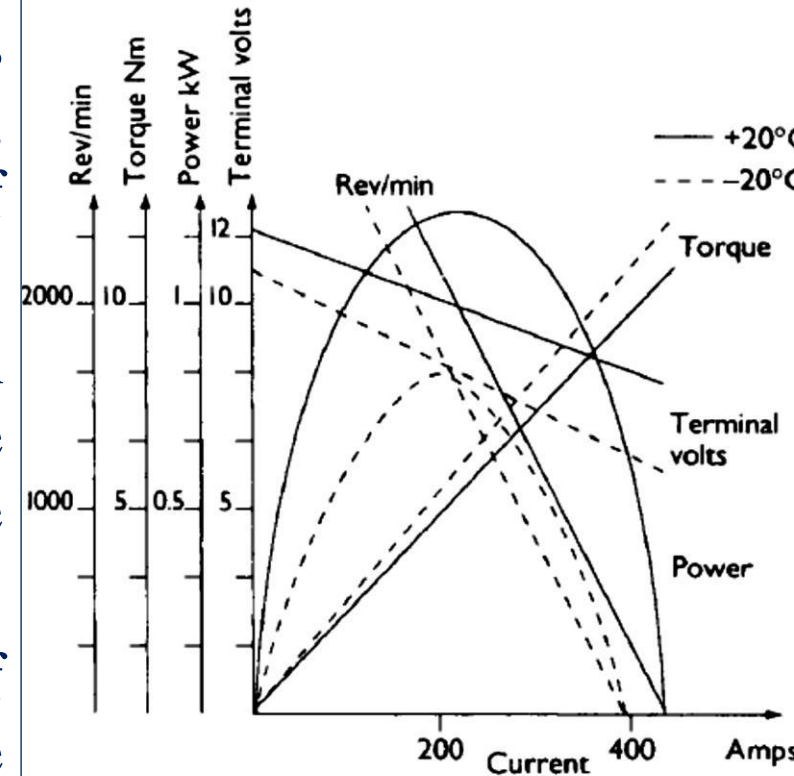

Curves of a 12 V 0.9 kW starter using the maximum size battery of 55 Ah, 255 A

❖ Starting System Layout:

- In comparison with most other circuits on the modern vehicle, the starter circuit is very simple.
- The problem to be overcome, however, is that of volt drop in the main supply wires.
- The starter is usually operated by a spring-loaded key switch, and the same switch also controls the ignition and accessories.
- The supply from the key switch, via a relay in many cases, causes the starter solenoid to operate, and this in turn, by a set of contacts, controls the heavy current.
- In some cases an extra terminal on the starter solenoid provides an output when cranking, which is usually used to bypass a dropping resistor on the ignition or fuel pump circuits.
- The basic circuit for the starting system is shown in Figure

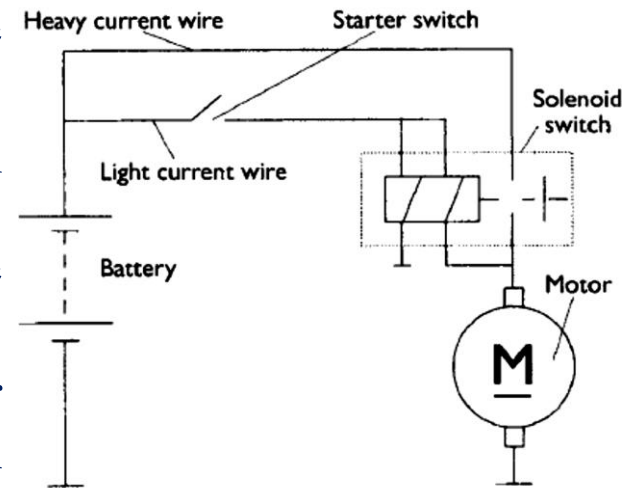



- The problem of volt drop in the main supply circuit is due to the high current required by the starter, particularly under adverse starting conditions such as very low temperatures.
- A typical cranking current for a **light vehicle engine is of the order of 150 A**, but this may peak in excess of **500 A to provide the initial stalled torque**.
- It is generally accepted that a maximum volt drop of only 0.5 V should be allowed between the battery and the starter when operating.
- An Ohm's law calculation indicates that the maximum allowed circuit resistance is 2.5mΩ when using a 12 V supply.
- This is a worst case situation and lower resistance values are used in most applications.
- The choice of suitable conductors is therefore very important.



❖ Drive Mechanisms:

- The starting motor makes use of some sort of gear reduction in order to transmit its starting power to the engine.
- Keeping in view its present size, it would not have been possible for the motor to drive the engine, had it been coupled directly to the crankshaft of the engine.
- The general method of gear reduction makes use of pinion on the armature shaft which engages with the flywheel ring gear.
- The general gear reduction ratio used is of the order of 10 to 16.
- The starting motor may revolve as fast as up to 3000 rpm making the engine to run up to 200 rpm.
- Once the engine has started operating under its own power, it may attain speed up to 4000 rpm.



- If pinion not disengaged, the armature of the starting motor is likely to be spun at the terrific speed of about 60000 rpm.
- This speed is likely to damage the cranking motor throwing the windings out of the armature slots and also the commutator segments due to centrifugal force.
- In order to prevent this, it is necessary to provide some means of automatic engaging and disengaging of the pinion from the flywheel ring gear.



- **The drives used are as follows,**
 1. Bendix drive (Inertia Type)
 2. Folo-thru drive
 3. Barrel type drive
 4. Rubber compression drive
 5. Compression spring bendix
 6. Friction clutch drive
 7. Overrunning clutch (Pre-engaged Starters)
 8. Dyer drive
 9. Axial or sliding armature

❖ Inertia Starters (Bendix Drive):

- Invented by Vincent Hugo Bendix in 1910.
- The inertia type of starter motor has been the technique used for over 80 years, but is now becoming redundant.
- The starter shown in Figure is the Lucas M35J type. It is a four-pole, four-brush machine and was used on small to medium-sized petrol engine vehicles.
- It is capable of producing **9.6 Nm with a current draw of 350 A**. The M35J uses a face-type commutator and axially aligned brush gear. The fields are wave wound and are earthed to the starter yoke.

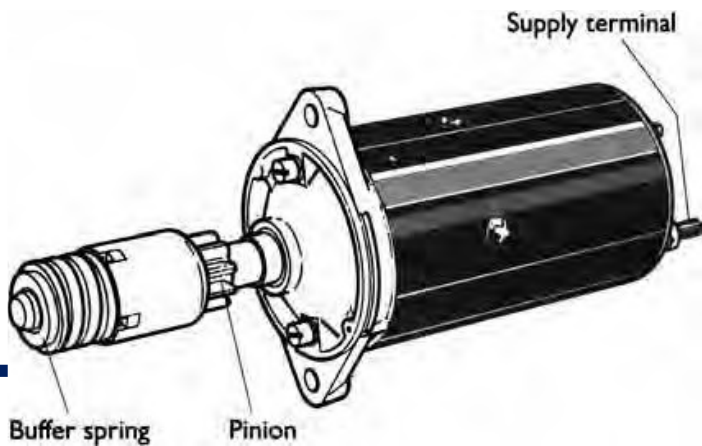

- The starter engages with the flywheel ring gear by means of a small pinion. The toothed pinion and a sleeve splined on to the armature shaft are threaded such that when the starter is operated, via a remote relay, the armature will cause the sleeve to rotate inside the pinion.
- The pinion remains still due to its inertia and, because of the screwed sleeve rotating inside it, the pinion is moved to mesh with the ring gear.
- When the engine fires and runs under its own power, the pinion is driven faster than the armature shaft.

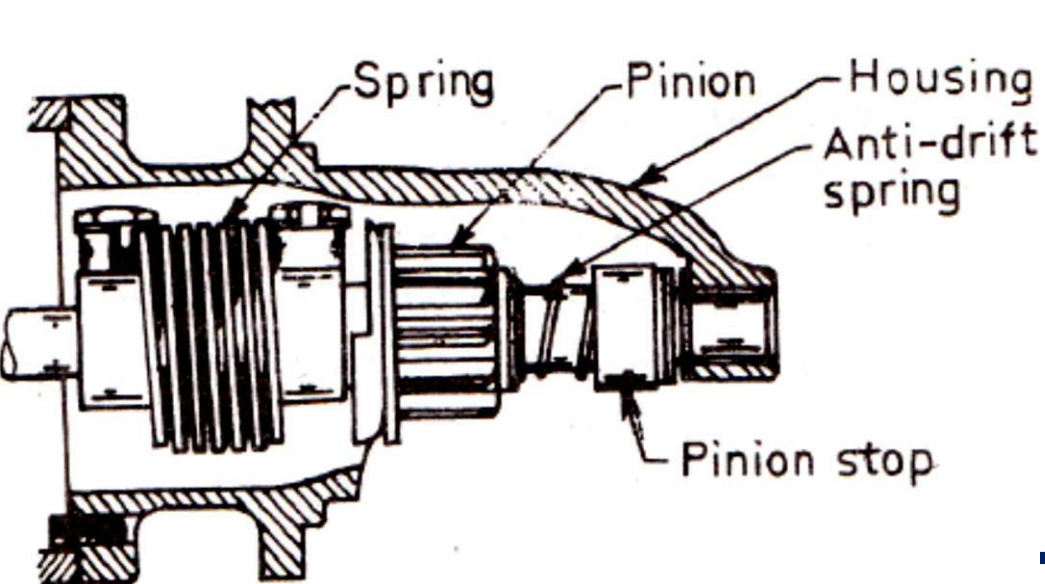

316482

A J Bhosale

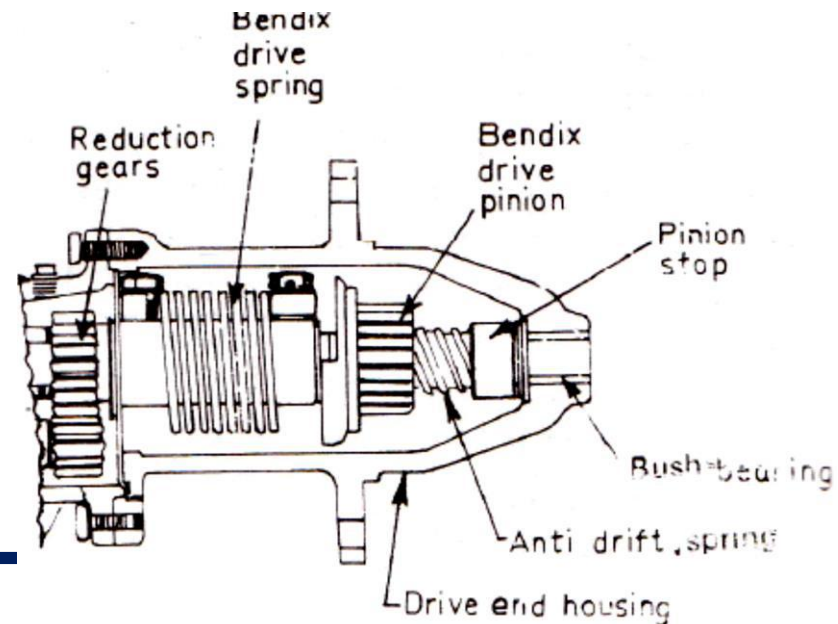

- This causes the pinion to be screwed back along the sleeve and out of engagement with the flywheel.
- The main spring acts as a buffer when the pinion first takes up the driving torque and also acts as a the buffer when the engine throws the pinion back out of mesh.
- One of the main problems with this type of starter was the aggressive nature of the engagement.
- This tended to cause the pinion and ring gear to wear prematurely. In some applications the pinion tended to fall out of mesh when cranking due to the engine almost, but not quite, running.

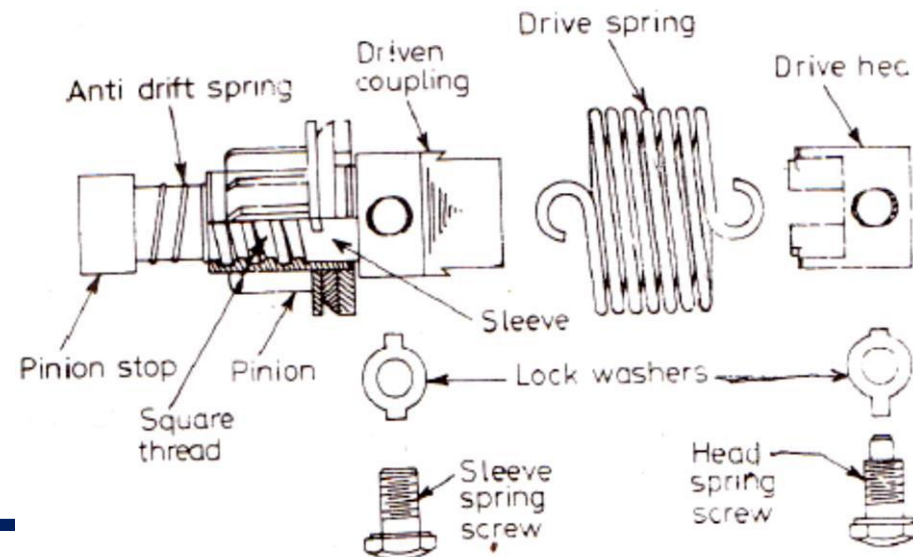



- The pinion was also prone to seizure often due to contamination by dust from the clutch.
- This was often compounded by application of oil to the pinion mechanism, which tended to attract even more dust and thus prevent engagement.



❖ Pre-engaged Starters:

- Pre-engaged starters are fitted to the majority of vehicles in use today. They provide a positive engagement with the ring gear, as full power is not applied until the pinion is fully in mesh.
- They prevent premature ejection as the pinion is held into mesh by the action of a solenoid. A one-way clutch is incorporated into the pinion to prevent the starter motor being driven by the engine.
- One example of a pre-engaged starter in common use is shown in Figure, the Bosch EF starter.

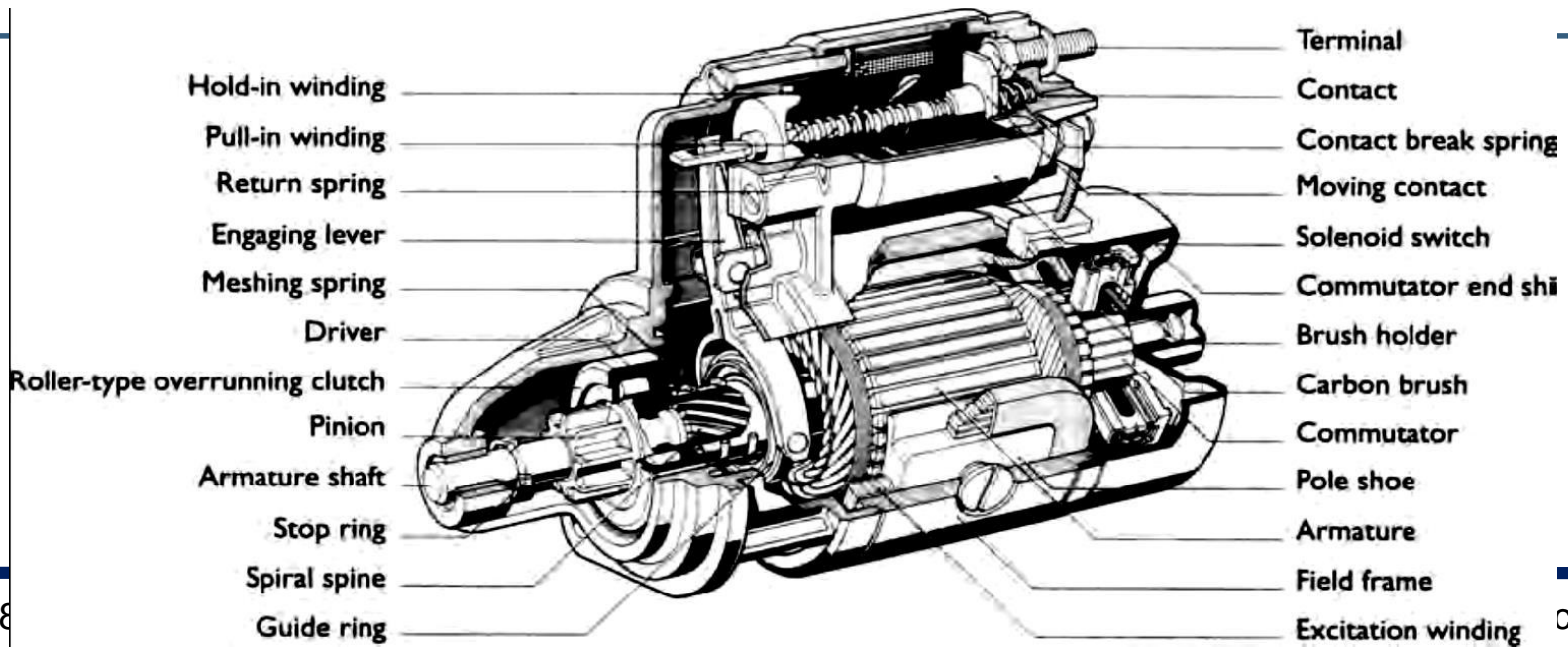

- Figure shows the circuit associated with operating this type of pre-engaged starter. The basic operation of the pre-engaged starter is as follows.
- When the key switch is operated, a supply is made to terminal 50 on the solenoid. This causes two windings to be energized, the hold-on winding and the pull-in (draw-in) winding. Note that the pull-in winding is of very low resistance and hence a high current flows.

This winding is connected in series with the motor circuit and the current flowing will allow the motor to rotate slowly to facilitate engagement.

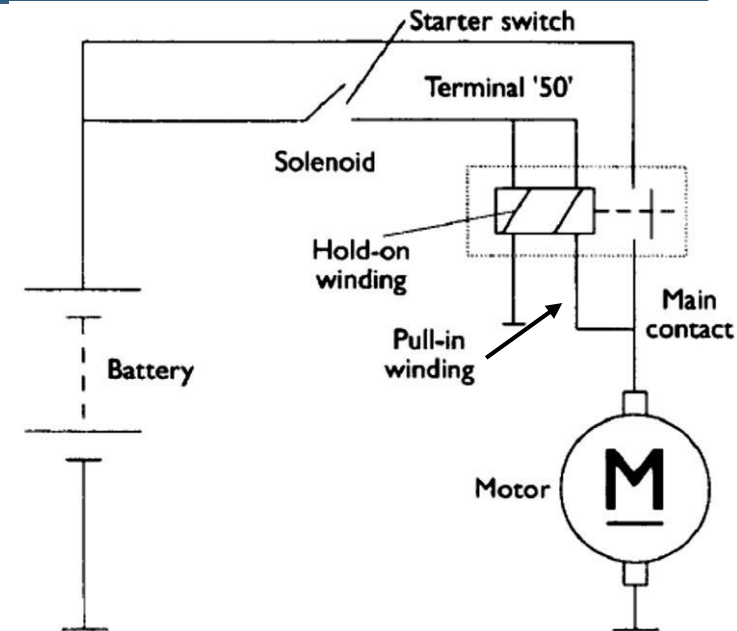

- At the same time, the magnetism created in the solenoid attracts the plunger and, via an operating lever, pushes the pinion into mesh with the flywheel ring gear.
- When the pinion is fully in mesh the plunger, at the end of its travel, causes a heavy-duty set of copper contacts to close. These contacts now supply full battery power to the main circuit of the starter motor.
- When the main contacts are closed, the pull-in winding is effectively switched off due to equal voltage supply on both ends.
- The hold-on winding holds the plunger in position as long as the solenoid is supplied from the key switch.

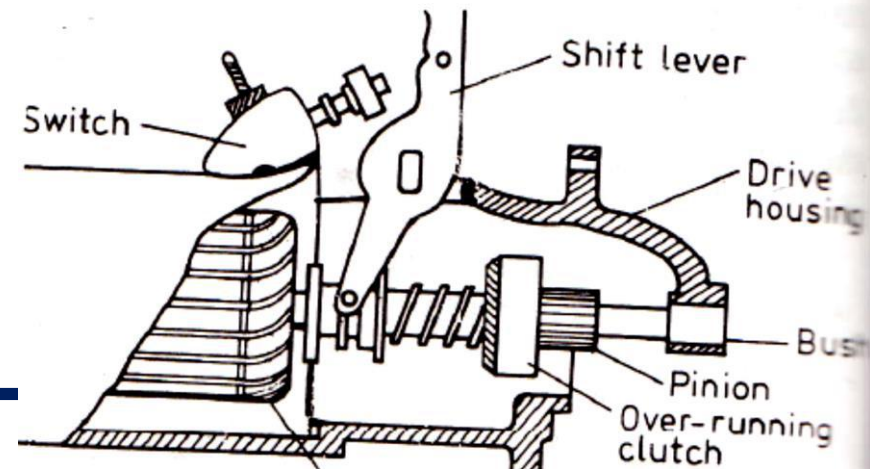

Manually Operated Overrunning Clutch

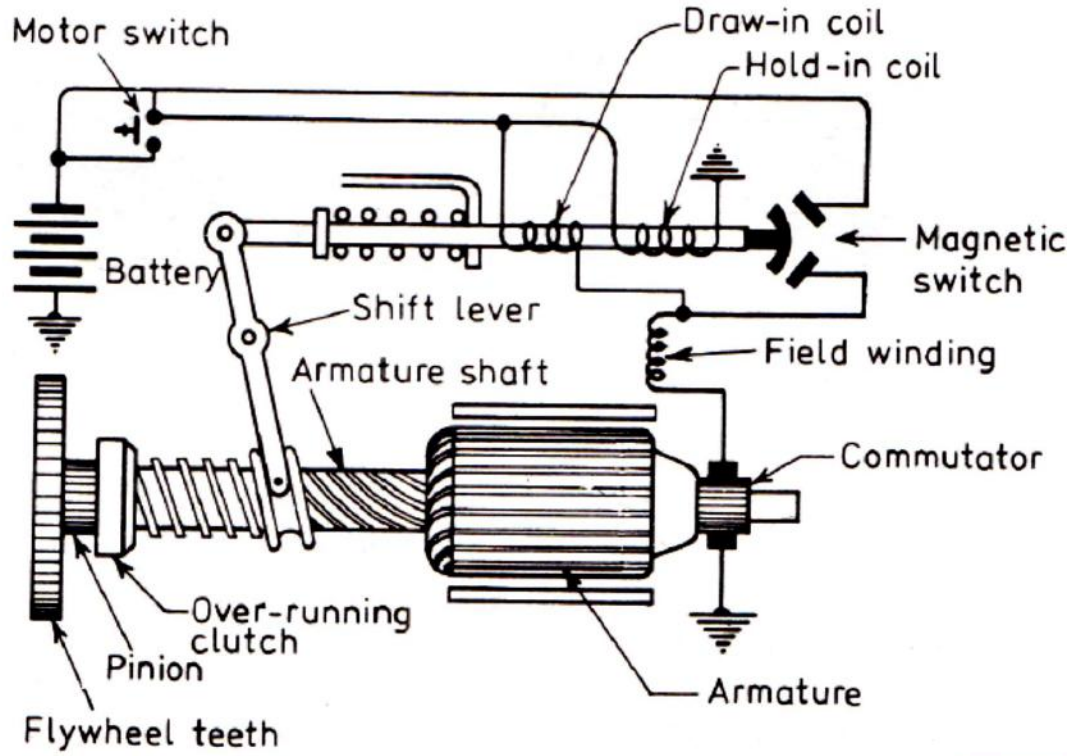

(a) Disengaged position

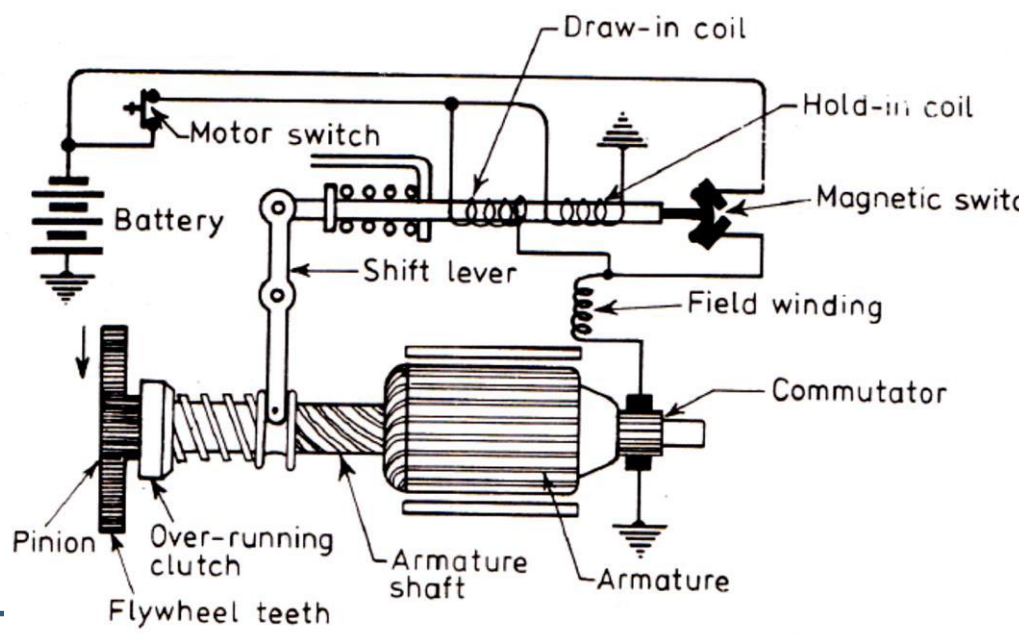

(b) Pinion engaged and motor cranking



- When the engine starts and the key is released, the main supply is removed and the plunger and pinion return to their rest positions under spring tension.
- A lost motion spring located on the plunger ensures that the main contacts open before the pinion is retracted from mesh.
- During engagement, if the teeth of the pinion hit the teeth of the flywheel (tooth to tooth abutment), the main contacts are allowed to close due to the engagement spring being compressed. This allows the motor to rotate under power and the pinion will slip into mesh.

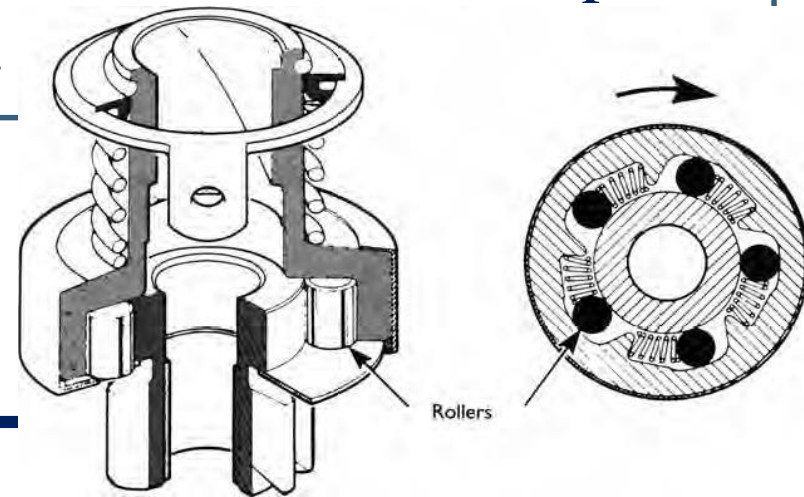



- Figure shows a sectioned view of a one-way clutch assembly. The torque developed by the starter is passed through the clutch to the ring gear.
- The purpose of this free-wheeling device is to prevent the starter being driven at an excessively high speed if the pinion is held in mesh after the engine has started.
- The clutch consists of a driving and driven member with several rollers between the two. The rollers are spring loaded and either wedge-lock the two members together by being compressed against the springs, or free-wheel in the opposite direction.
- Many variations of the pre-engaged starter are in common use, but all work on similar lines to the above description. The wound field type of motor has now largely been replaced by the permanent magnet version.

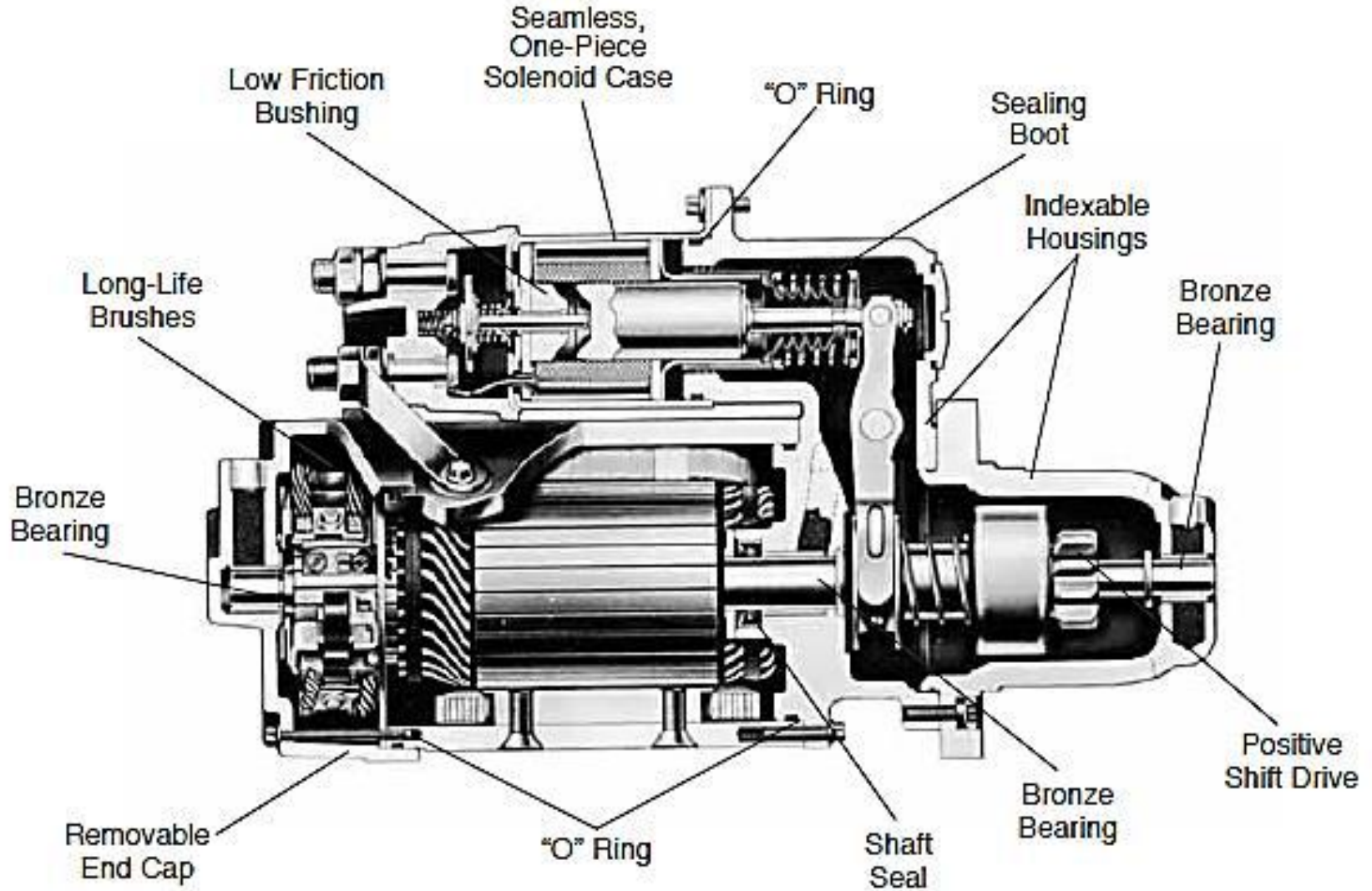



❖ Ignition System: (Requirements)

- The fundamental purpose of the ignition system is to supply a spark inside the cylinder, near the end of the compression stroke, to ignite the compressed charge of air–fuel vapor.
- For a spark to jump across an air gap of 0.6mm under normal atmospheric conditions (1 bar), a voltage of 2–3 kV is required.
- For a spark to jump across a similar gap in an engine cylinder, having a compression ratio of 8 : 1, approximately 8 kV is required. For higher compression ratios and weaker mixtures, a voltage up to 20 kV may be necessary.
- The ignition system has to transform the normal battery voltage of 12 V to approximately 8–20 kV and, in addition, has to deliver this high voltage to the right cylinder, at the right time. Some ignition systems will supply up to 40 kV to the spark plugs.



- Conventional ignition is the forerunner of the more advanced systems controlled by electronics.
- It is worth mentioning at this stage that the fundamental operation of most ignition systems is very similar.
- One winding of a coil is switched on and off causing a high voltage to be induced in a second winding.
- A coil-ignition system is composed of various components and sub-assemblies, the actual design and construction of which depend mainly on the engine with which the system is to be used.



■ When considering the design of an ignition system many factors must be taken into account, the most important of these being:

- Combustion chamber design.
- Air–fuel ratio.
- Engine speed range.
- Engine load
- Engine combustion temperature.
- Intended use.
- Emission regulations.

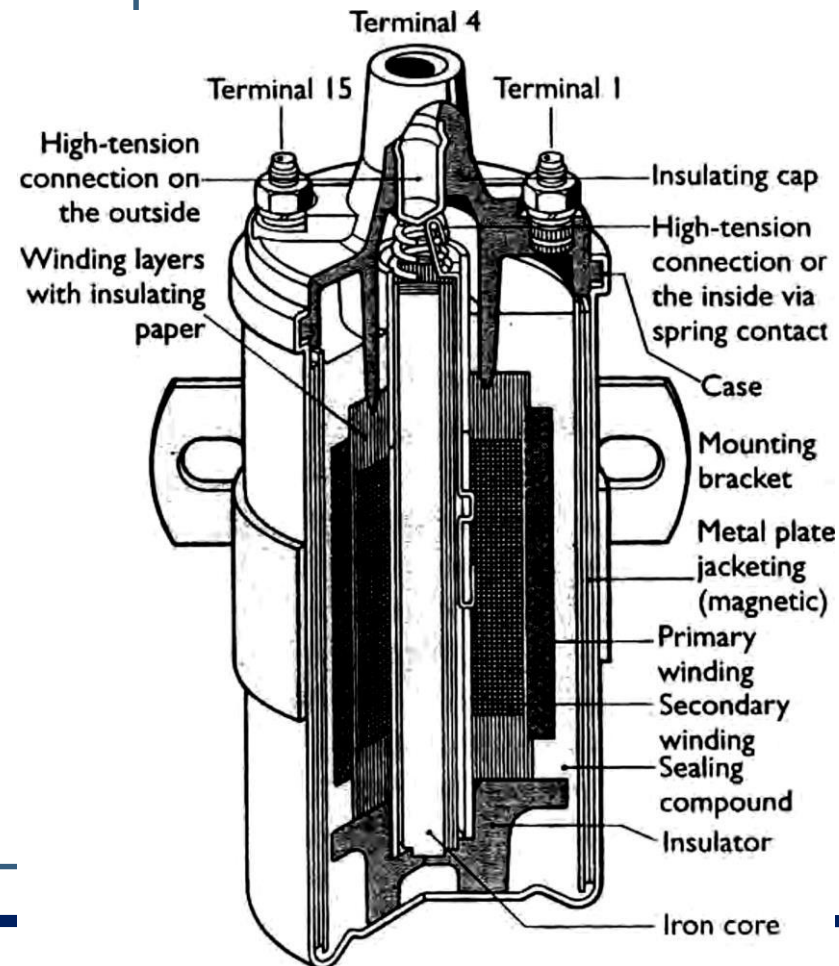

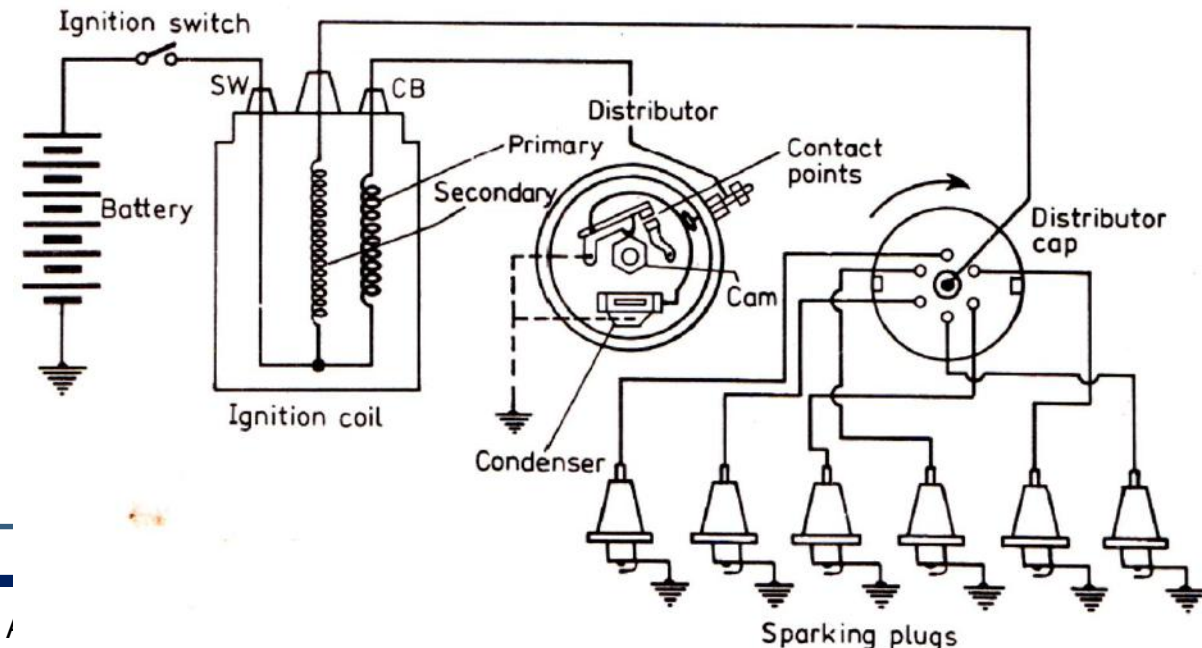
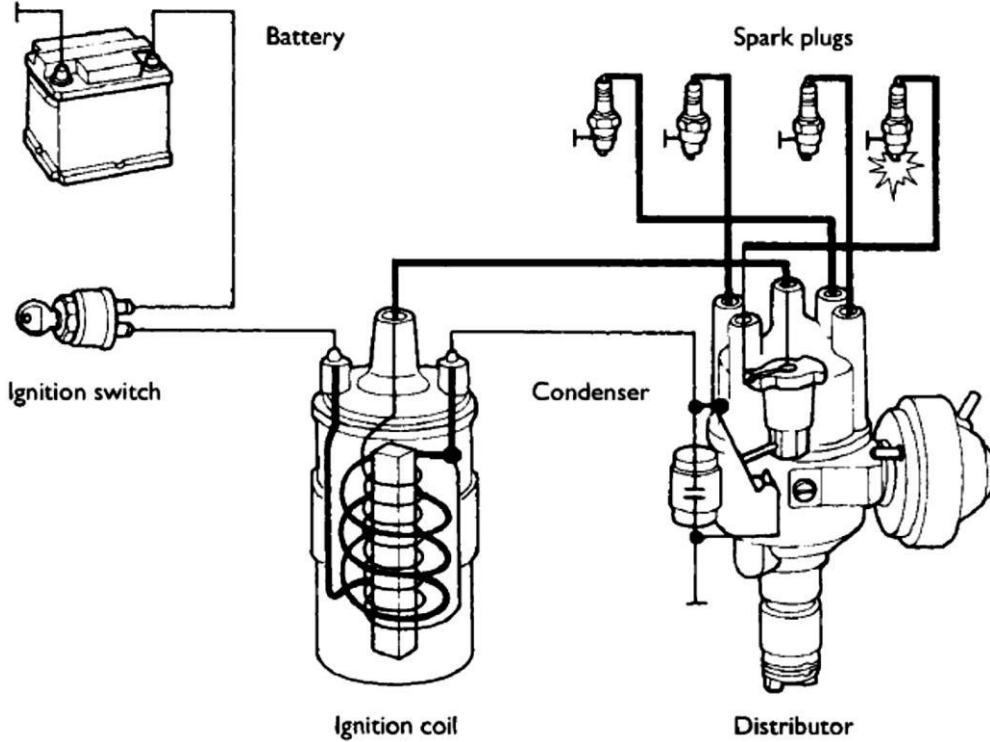



- If two coils (known as the primary and secondary) are wound on to the same iron core then any change in magnetism of one coil will induce a voltage into the other. This happens when a current is switched on and off to the primary coil. If the number of turns of wire on the secondary coil is more than the primary, a higher voltage can be produced. This is called *transformer action* and is the principle of the ignition coil.
- The value of this ‘mutually induced’ voltage depends upon:
 - The primary current.
 - The turns ratio between the primary and secondary coils.
 - The speed at which the magnetism changes.
- Figure on previous slide shows a typical ignition coil in section. The two windings are wound on a laminated iron core to concentrate the magnetism. Some coils are oil filled to assist with cooling.



❖ Conventional Ignitions System Components

1. Spark plug

- Seals electrodes for the spark to jump across in the cylinder. Must withstand very high voltages, pressures and temperatures.

2. Ignition coil

- Stores energy in the form of magnetism and delivers it to the distributor via the HT lead. Consists of primary and secondary windings.

3. Ignition switch

- Provides driver control of the ignition system and is usually also used to cause the starter to crank.

4. Ballast resistor

- Shorted out during the starting phase to cause a more powerful spark. Also contributes towards improving the spark at higher speeds.



5. Contact breakers (breaker points)

- Switches the primary ignition circuit on and off to charge and discharge the coil.

6. Capacitor (condenser)

- Suppresses most of the arcing as the contact breakers open. This allows for a more rapid break of primary current and hence a more rapid collapse of coil magnetism, which produces a higher voltage output.

7. HT Distributor

- Directs the spark from the coil to each cylinder in a pre-set sequence.

8. Centrifugal advance

- Changes the ignition timing with engine speed. As speed increases the timing is advanced.

9. Vacuum advance

- Changes timing depending on engine load. On conventional systems the vacuum advance is most important during cruise conditions.

❖ Ignition Coil:

- In the beginning, it was the usual practice to wind the primary coil over the core and the secondary coil over the primary coil.
- But nowadays, the primary coil is wound over the secondary coil. The later arrangement gives stronger magnetic field. The mutual inductance is also higher for the latter arrangement than for the former type.
- The arrangement of primary wound over secondary reduces the length of relatively expensive fine gauge secondary wire.
- It also reduces the amount of insulation between the outside of the coil and the frame, provided the core is insulated from the frame.

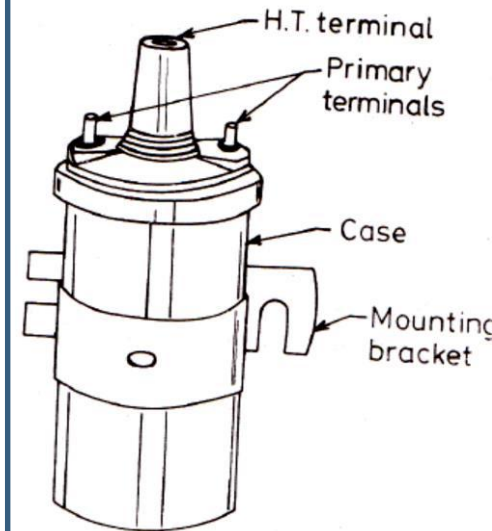
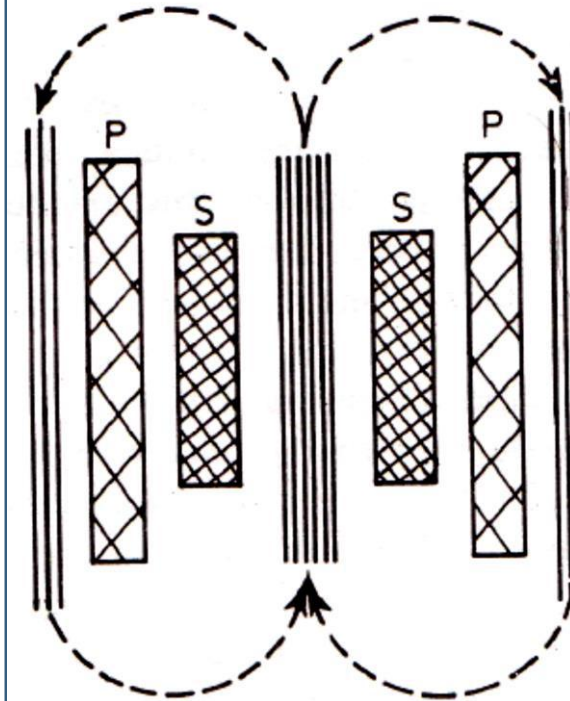
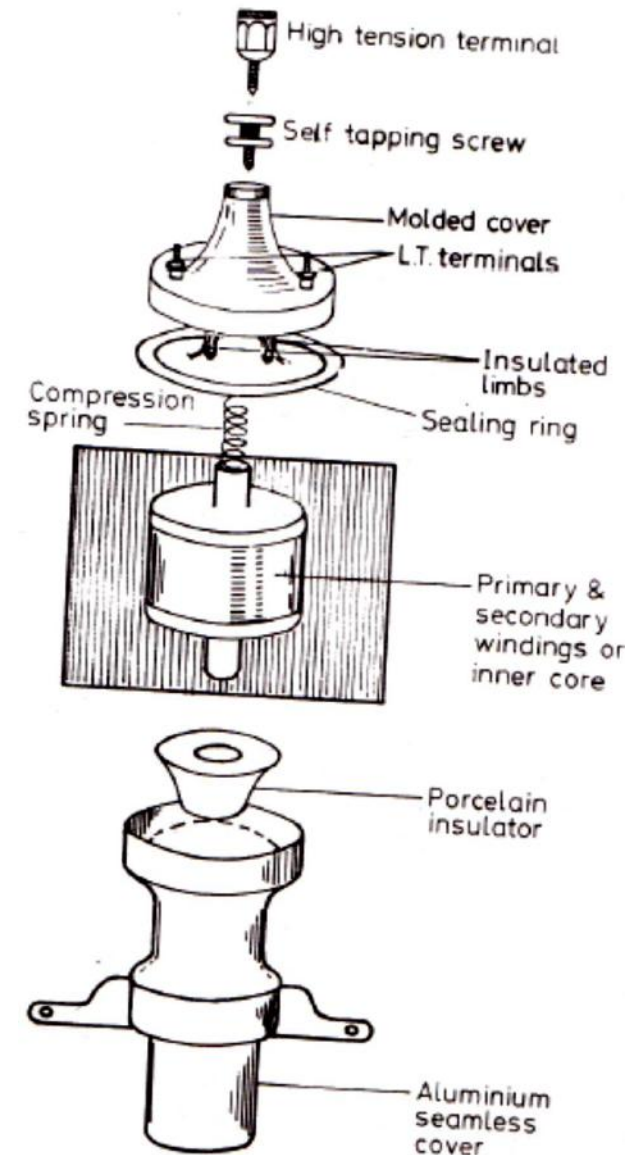

Fig. 7.6 An ignition coil.

- The marked advantage in winding the primary coil over the secondary coil in that there is better heat flow from the primary windings to the case of the ignition coil.
- Further, when the primary coil is outside, its resistance can be conveniently increased, so that the ballast resistance is dispensed with.
- Two types of ignition coil construction have been used, namely, open core with a long air-gap and closed core with a short air-gap.
- Figure shows the open-core ignition coil with the primary wound over the secondary.



- This type of construction is generally used in modern ignition coils. However, it may be mentioned that both the constructions can be so designed as to give fully satisfactory ignition coil operation.
- The open-core type ignition coil need more copper than the closed core type, although the latter needs more iron in the circuit
- The figure shows an exploded view of the ignition coil.
- The core of the coil is made of iron laminations of 24-28 SWG (Standard wire gauge) thickness (0.559- 0.3759 mm Dia.) and insulated by a coating varnish or enamel.





- On the core, first the secondary winding of about 20,000 turns of 44SWG (0.0813 mm dia.) enamel covered wire is wound and the layers are insulated from each other by thin paper strips. The resistance of the winding is of the order of 2000-4000 Ω .
- More recently, with the higher voltage requirements at the spark plugs, the windings have been increased, giving the resistance of 7000-9000 Ω .
- The primary winding is wound over the secondary winding and it is insulated with varnish paper. It consists generally of a few hundred turns of enameled copper wire having a low resistance of 0.8-1.5 Ω .
- In case of the 12V coil, the primary winding has about 360 turns of 25.5 SWG enameled wire. It may be noted that the resistance of the primary circuit is such that in most cases, the current drawn from the battery is about 2-2.5 A when the engine is at rest and it is about 3.5-5.0 A when engine is running.



❖ **Distributor:**

- The distributor performs two functions, namely, it opens and closes the primary circuit of the ignition coil and it distributes the resulting high voltage surges from secondary winding of the ignition coil to various spark-plugs of the engine.
- There are two types of distributors, viz.
 1. distributors with contact points and
 2. distributors with magnetic pick-up's.



Distributors with contact points:

- These type of distributors consists of the following parts:
 1. Housing
 2. Drive shaft having advance mechanism and breaker cam
 3. Breaker plate having condenser and contact points
 4. Rotor
 5. Cap
- The camshaft drives the distributor shaft through spiral gears. It roates at one half the speed in case of a four stroke engine.
- The contact points are opened and closed by the rotation of the shaft and breaker cam.
- There are the same number of lobes on braker cam as the number of cylinders in the engine.



- The contact points open and close once with every breaker cam rotation for each cylinder. The rotor is mounted on the breaker cam and rotates along with it.
- As it rotates, a segment on the rotor and a metal spring connect the central terminal of the cap with each outside terminal leading to plugs in turn.
- It thus distributes the high voltage surges from the coil to the spark plugs according to the firing order.

❖ Distributors with magnetic pick-up:

- Fig. shows the simple wiring diagram of the ignition system using the magnetic pulse distributor and transistor control unit.
- The magnetic pulse amplifier unit is connected between the primary winding and the battery.
- It permits the current to flow to the primary winding and interrupt the same in a signal from the distributor.
- This action is similar to that of the opening and closing of the points in case of a distributor with contact points.

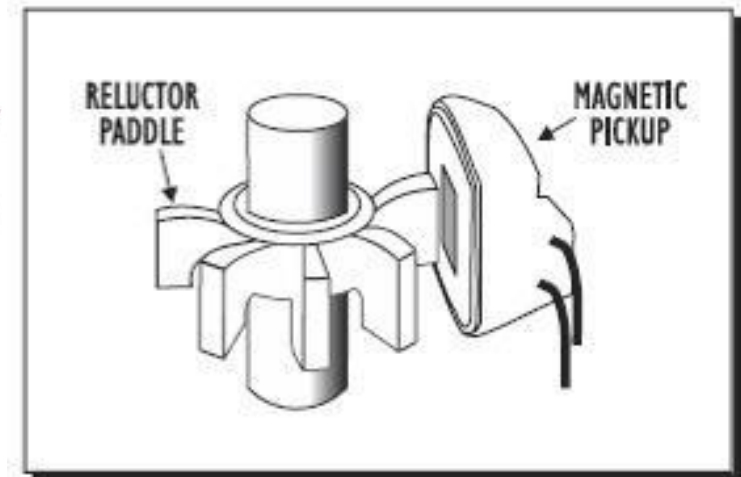
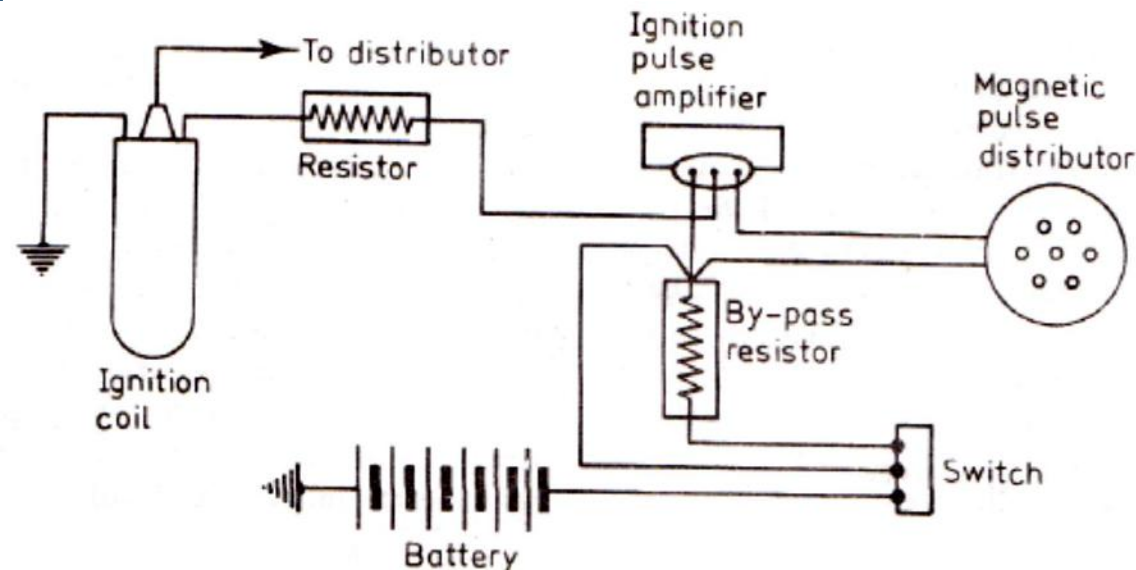

- The magnetic pick-up distributor is mounted and driven in the same manner as other distributors.
- The magnetic pick-up contains a permanent magnet on the top of which a pole piece is mounted. It provides signals to the amplifier.
- The pole piece has a series of teeth which point inwards. The number of teeth is same as the number of cylinders in the engine.
- There is pick-up coil which having number of turns of wire inside the permanent magnet.

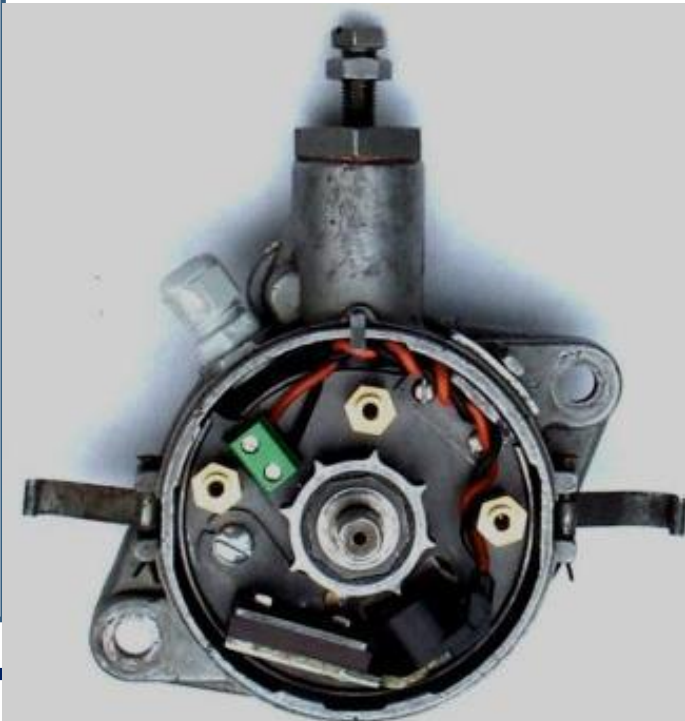
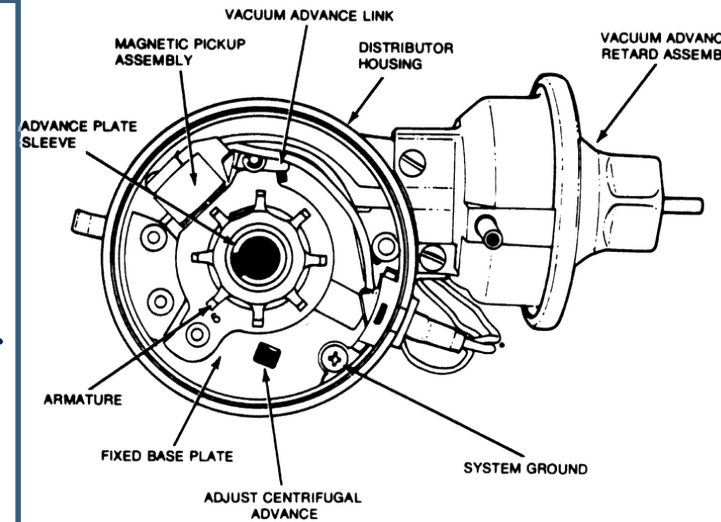

❖ Cam angle and contact point gap

- The cam or dwell angle is the number of degrees travelled by the distributor cam while the contact points are closed.
- The usual value of cam angle for a six-cylinder engine is of the order of $32-37^\circ$ and the general value used is 36° .
- It means that during the 60° of cam rotation meant for the firing of each cylinder, the contact points remain closed for 36° and open for the remaining 24° .
- It is evident that an increase in the contact points gap will result in a decreased cam angle and vice versa.

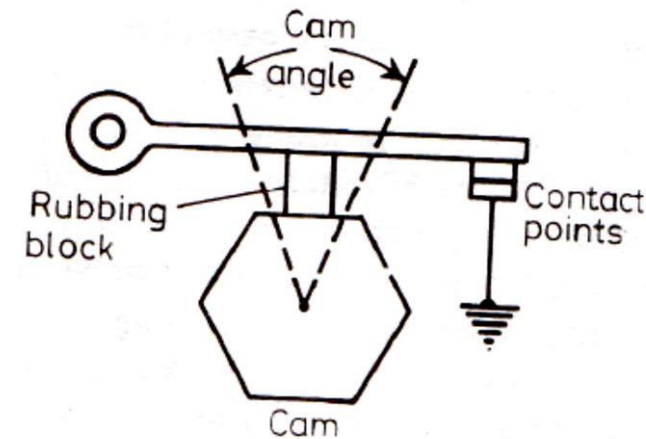



- The 8 cylinder engine has a cam angle of about $26-30^{\circ}$ which is smaller than that of the 6-cylinder engine.
- The 4-cylinder engine has a larger cam angle, of the order of 41° , than that of the 6-cylinder engine.
- The figure above shows the measurement of cam angle. The cam angle or dwell angle can be measured with the help of the cam angle or dwell meter.
- The dwell meter is connected across the distributor during operation in the engine or while the distributor is being turned in a test stand.
- In some of the service procedures, it is recommended that the cam angle be set with a meter, whereas in others the preference is to adjust the contact points gap to the correct clearance.
- The feeler or dial gauge is utilized for measuring the gap when the points are at their widest opening.



- It is important to keep the correct cam angle because when the points are closed the coil is building up, which will make available the proper amount of high tension current at the spark plug when the contact points are opened.
- If the contact points are adjusted too closely, the engine will not run smoothly as the contact points will not remain open long enough to give the ignition coil a chance to do its work.
- On the other hand, if the contact points are adjusted with too much clearance, the engine will miss at high speeds because the contact points will not be closed long enough to allow the ignition coil to build up properly.
- Hence, it is of utmost importance to adjust the contact points gaps to the correct clearance or cam angle before adjusting the ignition timing.



- Contact breaker is a mechanical device for making and breaking the primary circuit of the ignition coil whenever demanded. This is done by using a mechanically operated cam. The Fig. shows the contact breaker assembly. It consists of two metal point viz. fixed metal point and movable metal point on spring loaded arm. The fixed metal point (generally made up of tungsten) bears against movable metal point.
- The movable arm is spring loaded so whenever these points are closed, the spring ensures a good contact between these points. These points are made of circular flat face of 3 mm in diameter each. When the contact breaker points are open (not connected), the electric current flow stops and when they are closed (connected) the electric current flow starts.

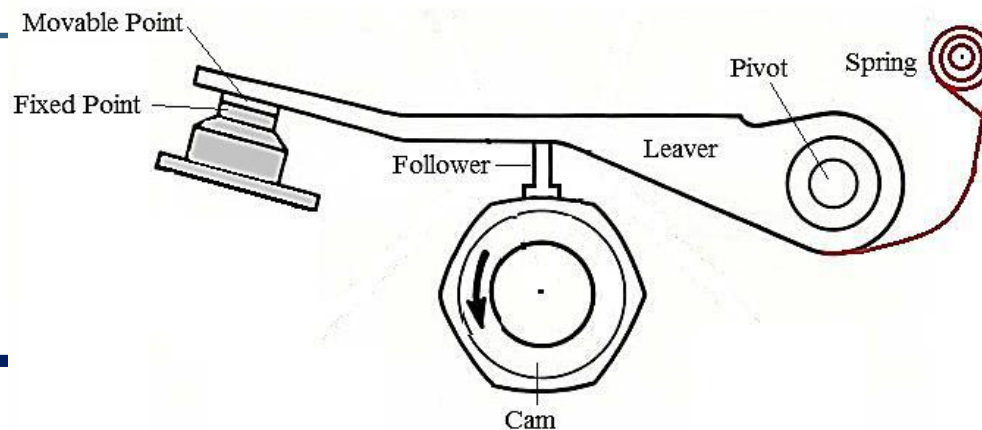

□ Capacitor:

- The capacitor acts as an electric energy storage device. The capacitor is made up of two conductor plates separated by an insulating material. They are placed face to face.
- These conductor plates are narrow and long made of lead or aluminium foil, these are insulated by a special type of insulating material. These are wrapped on an arbor which forms a winding. This winding assembly is placed in one container.
- The capacitor absorbs or minimizes the arcing and pitting of the points.
- It is an essential part ignition system. Without the use of capacitor or with the faulty capacitor, no engine will run.

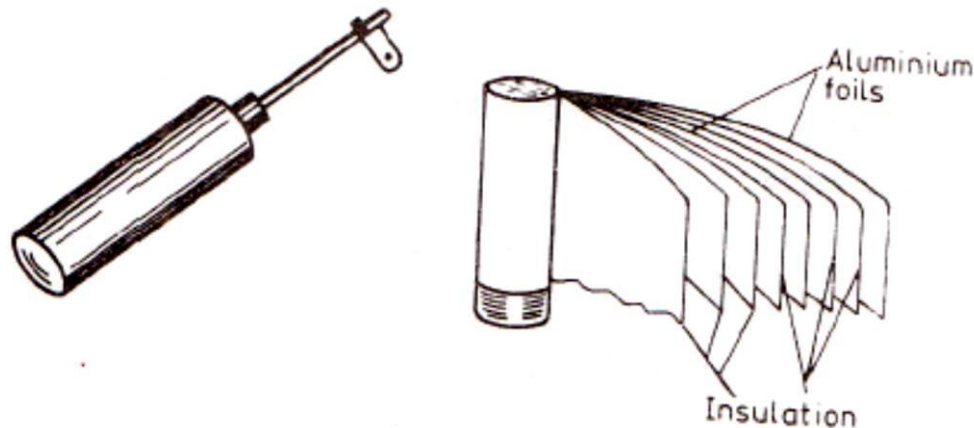

Fig. 7.9 Assembled and partially disassembled capacitor



❖ Spark Advance Mechanism:

- There are a number of variables to determine the correct instant for producing a spark into the cylinder. Engine speed is one of the most important ones. At high engine speeds, it is very essential to make the spark occur earlier in the compression stroke, in order to ignite the mixture effectively and thus deliver its power to the piston of the engine.
- Depending upon the design of the engine, speed, compression ratio and other minor factors, the spark must occur about $20-40^\circ$ in advance before the piston reaches its top dead center during compression stroke.
- It may be noted that when the spark is over-advanced, not only loss of power takes place but there is a tendency for the engine to run rough with probable detonation effects because of more rapid rates of pressure rise and attainment of appreciable higher pressures.



- On the other hand, when the spark is retarded in relation to its correct position, there is reduced power output due to late combustion. Also, the engine will have the tendency of overheating, leading to pre-ignition of the charge before the spark takes place. Even too much advance spark can lead to overheating.
- There are two general ways of advancing the spark, viz. centrifugal and vacuum. The spark timing is varied for different engine operating conditions with the help of these methods.

❑ Centrifugal Advance Mechanism:

- The centrifugal advance mechanism consists of two weights which are thrown out against spring tension as the engine speed increases.
- The weights are hinged and are moved outwards by the centrifugal action, resulting in change of angular relation of the driving and the driven shafts.
- This movement is transmitted to the breaker cam through a toggle arrangement or to the timer core on a magnetic pick up type distributor.
- In turn, it moves ahead the cam or the timer core with regard to the drive shaft of the distributor.

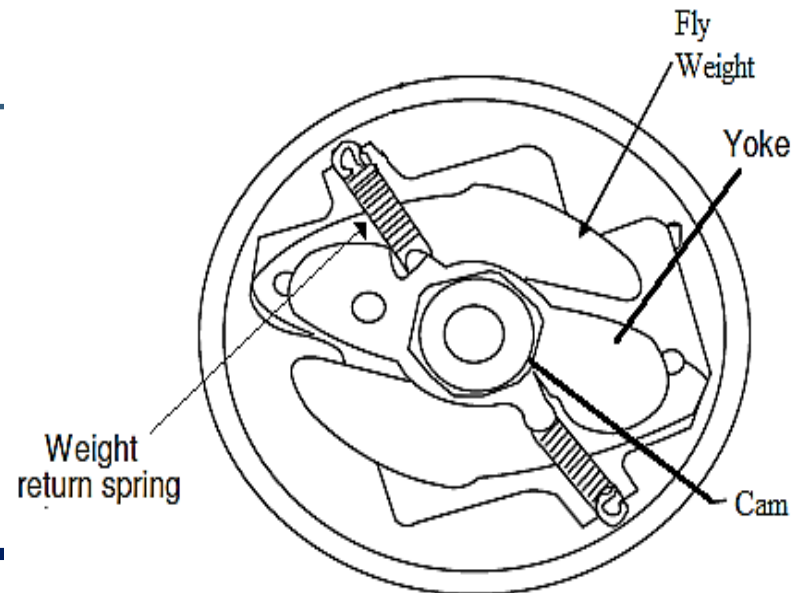

- At high speeds, the cam opens and closes the contact points earlier due to this advance in the case of the contact point distributor and in the case of magnetic pick-up distributors, the timer core advance making the pick-up coil to send its signals to the transistor control unit in advance.
- It may be noted that the advance spring strength and the contours of the toggle arrangement are designed in such a manner as to suit the requirements of the engine and to give advance at each engine speed so that maximum power and the best possible engine performance are obtained.

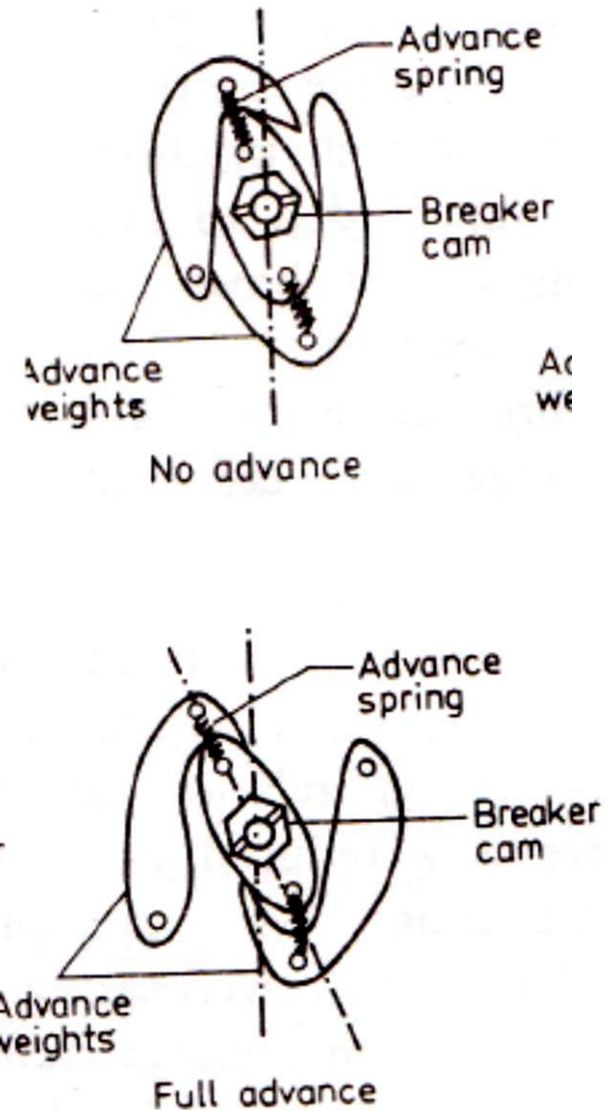
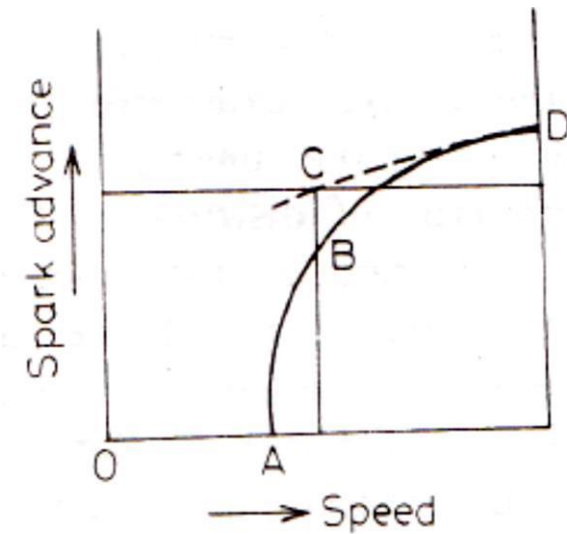

Fig. 7.18 Centrifugal advance mechanism in full and advance positions.

- Figure Shows the graph of engine speed and spark advance. Considering the engine idling and the correct initial ignition timing, the centrifugal advance mechanism should advance the timing as the increase in engine speed takes place.
- It should advance approximately in the manner as shown in figure. The curved portion AB of the curve corresponds to a more rapid increase of the timing from its idle speed OA.
- The portion BD of the curve is practically straight for full throttle conditions. It may be remembered that the centrifugal mechanism can be conveniently arranged to give the characteristic line CD





❑ Vacuum Advance Mechanism

- Fig. shows the simple line diagram of the vacuum advance mechanism.
- When the throttle is partly opened, the air admitted into the inlet-manifold is restricted which develops a vacuum in the inlet manifold.
- This means that the amount of air fuel admitted into the cylinder will be less.
- It will lower the volumetric efficiency. Hence the mixture will be less highly compressed which will result in a slower burning of the mixture when ignited.
- In order to obtain full power from it, the spark should be somewhat advanced. It is done with the help of the vacuum advance mechanism.
- It may be remembered that this spark advance mechanism is in addition to the centrifugal advance mechanism.



- The Fig. shows the vacuum advance mechanism. It consists of diaphragm, compression spring, cam, movable breaker plate, vacuum advance arm and contact breaker.
- The vacuum advance is suitable for **partial load operation**.
- The vacuum unit is connected to the intake manifold with the help of hose pipe. One end of vacuum advance arm is connected to the diaphragm and other end to movable breaker plate.
- In this, the spark advance extent depends on the vacuum present in intake manifold. The amount of vacuum created in intake manifold depends on the throttle position.
- As the pressure in the intake manifold changes, the diaphragm shifts against the spring (towards right), which in turn moves the breaker plate.

- This additional movement of breaker plate (against the direction rotation of distributor shaft) opens the breaker contact earlier in a cycle and supplies the spark.
- At partially open throttle, there will be less vacuum in intake manifold hence lesser will be the spark advance. There will be no spark advance for wide open throttle position.

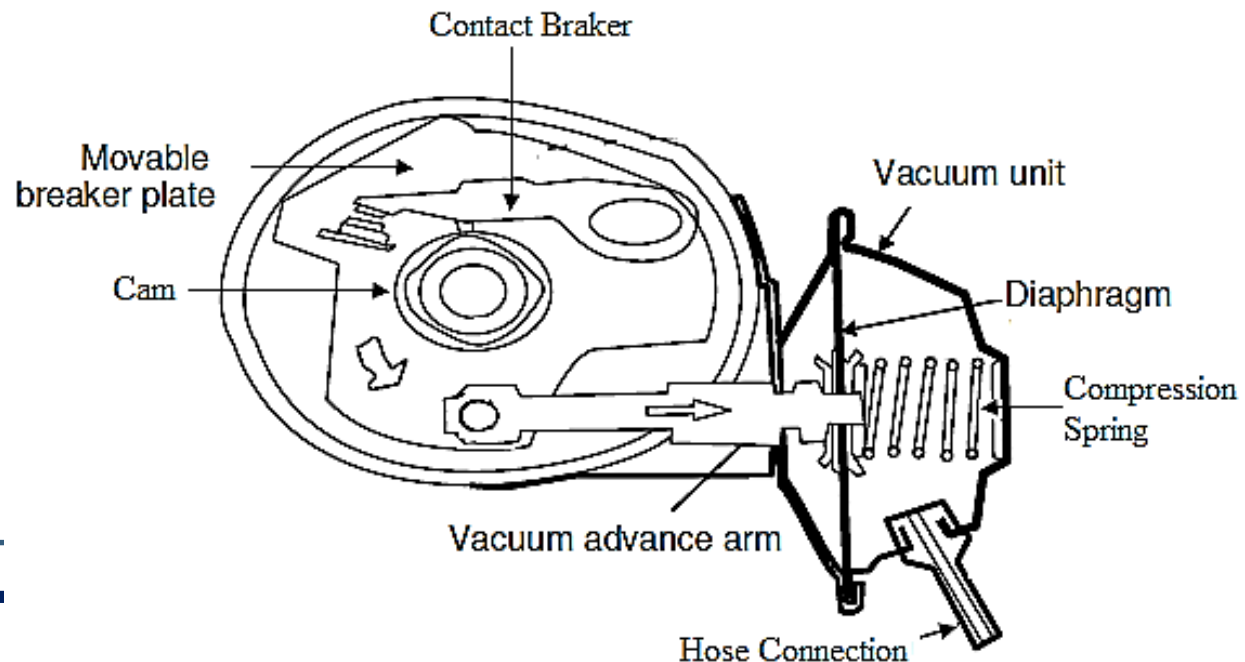



❑ Limitations of the Coil Ignition System:

- There has been a tendency in automobile engine design of using increased compression ratios of the order of 8.5 – 10.5. Further higher engine speeds of the order of 5000-6000 RPM in the production cars and up to 12000 RPM in the case of racing cars, are being used. There are certain limitations of the battery and coil ignition system at higher compression and engine speeds which are listed below.
 1. Due to mechanical trouble, the contact breaker has limitations to operate at these higher speeds. The present system has the limitations of a speed equivalent to a value corresponding to about 400 sparks per second.
 2. There is an increasing tendency of plug fouling due to the leaded fuels used with higher compression ratio engines to avoid detonation effects.



3. The high currents used with these systems cause the pitting or burning of the contact points.
4. The ignition timing inaccuracies at higher engine speeds because of torsional oscillations and back lash in the drive mechanism.
5. The limitation imposed by cam design with regard to its dwell times and efficient operation of contact-breaker at higher engine speeds.
6. Increasing high voltage is required to produce sparks at higher compression and engine speeds. The voltages applied are of the order of 20,000V and above.



❑ **Electronic Ignition System:**

- Modern day vehicles use electronic ignition system instead of conventional ignition systems described above due to large number of advantages.
- With the advances in solid state devices (semi-conductor and chips technology) over last few decades, modifications were done to conventional ignition system using transistor technologies.

❑ **Need of Electronic Ignition System (Limitations of Conventional Ignition System)**

- Conventional ignition systems have following limitations.
- Lower spark voltage at higher speeds
- Lower MTBF (Mean Time Between Failure) or Higher Failure Rates
- Pitting at contact breaker points which leads to mistimed firing and loss of power
- Frequent maintenance needs at contact breakers
- Starting problems especially when battery is discharged.



- To overcome the above stated limitations, following electronic ignition systems are nowadays used in most of the automobiles.
 - Transistorized Coil Ignition (TCI) System
 - Capacitor Discharge Ignition (CDI) System



❑ **Transistorized Coil Ignition (TCI) System**

- TCI System is nowadays most widely used ignition system in most of the automobiles (two and three wheeled vehicles)
- This system is also referred to as Transistor Assisted Contact (TAC) System
- Fig. shows TCI System. This system retains the contact breaker point used in conventional system.
- Contact breaker point (operated using cam and follower mechanism) is connected to the base of transistor.
- Emitter of the transistor is connected to the primary windings of the ignition coil and collector is electronically earthed (or grounded).

- The current flow in this system is around $1/10^{\text{th}}$ times lesser than the conventional ignition system.
- Ballast resistor is used to avoid the damage of ignition coil by overheating.
- Life of Contact breaker points is more due to use of transistor technology.

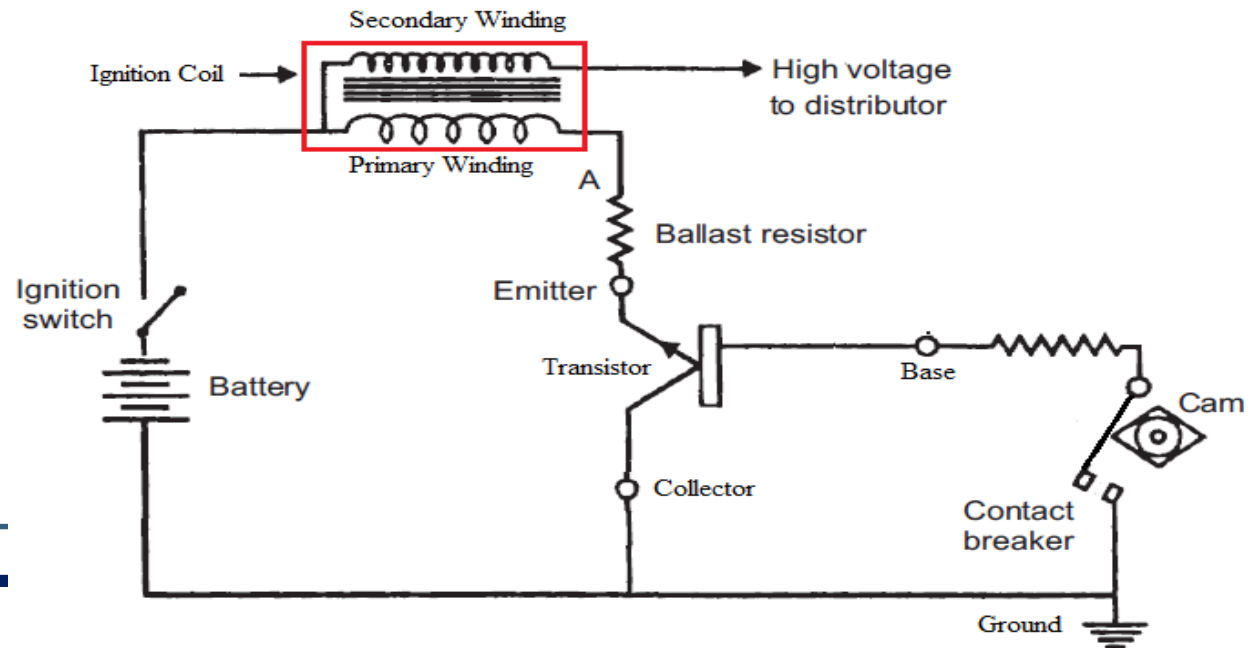



❖ **Advantages:**

- Reduced wear and tear of Contact Breaker Points
- No misfiring and no loss of power
- Higher ignition voltage
- Longer spark plug life thereby reducing running cost
- More reliable in operation
- Improved ignition even at lower air-fuel ratios (lean charge)
- Lower contact bouncing and increased dwell

❖ **Disadvantages:**

- Higher cost due to additional electronic components
- Contact Breaker CB Points are needed (i.e. they cannot be eliminated)
- Maximum engine speed is restricted by shortcomings of contact breaker mechanism

❖ **Applications:**

- Used in modern and new two wheelers like Royal Enfield Thunderbird, Hero Karizma ZMR, Yamaha FZ, Honda Dream Neo, Honda Dream Yuga etc.



❑ Capacitor Discharge Ignition (CDI) System

- Fig. shows CDI System which is another type of electronic ignition system.
- A 6 Volts battery is connected to DC to DC Transistor Control Unit which can give high voltage output (of the order of 300 Volts).
- Capacitor (also called as condenser) is charged to this output voltage.
- Resistance is used to control the current needed by SCR (Silicon Controlled Rectifier) so that firing angle of SCR can be changed as per the needs.
- Capacitor undergoes discharge when SCR triggering unit sends a pulse to create high voltage in secondary coil which causes current to jump across air gap between the electrodes producing the required spark.

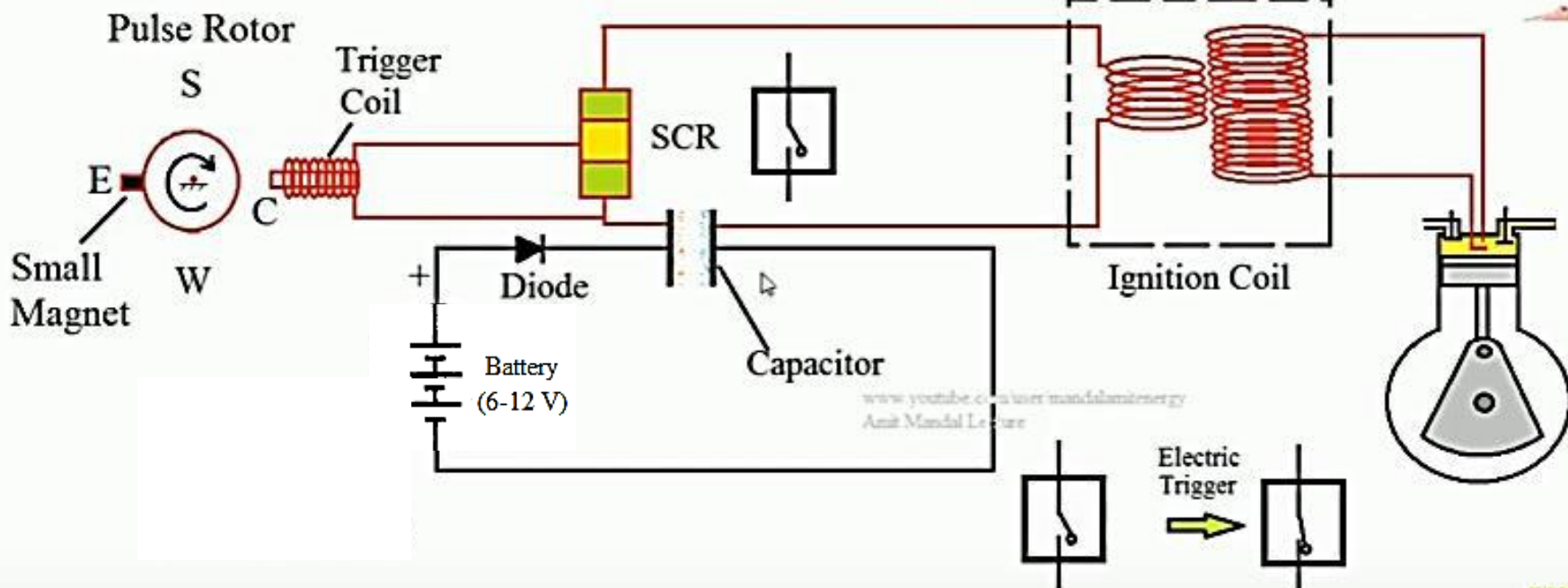
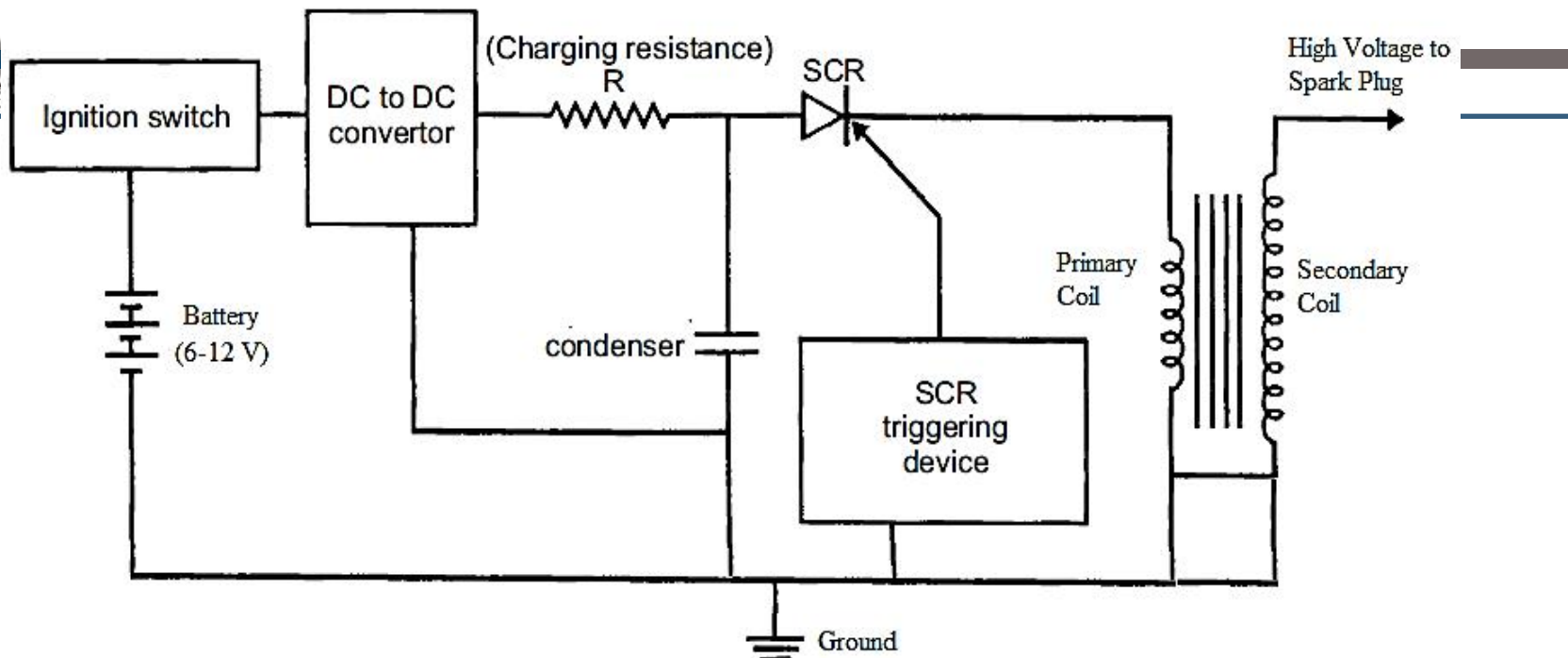



❖ **Advantages:**

- Need of CB (Contact Breaker) Points is eliminated
- Increased life of spark plug
- Better performance at all operating conditions
- Strength of spark is better
- Performance is not affected due to electrical shunts arising due to spark plug fouling

❖ **Disadvantages:**

- Higher cost due to additional components like capacitor, SCR (Silicon Controlled Rectifier)
- Fast capacitor discharge leads to strong spark, however, for very short duration of time (0.1 to 0.25 milliseconds) which can cause ignition failures at lower air-fuel ratios.

❖ **Applications:**

- Used in motorcycles, lawn mowers, chainsaws, small engines, turbine-powered aircrafts, and some cars. For example, Bajaj Discover 100, Bajaj Discover 150, Honda CB Twister, Honda CB Unicorn etc,

Performance Curves of Conventional and Electronic Ignition System

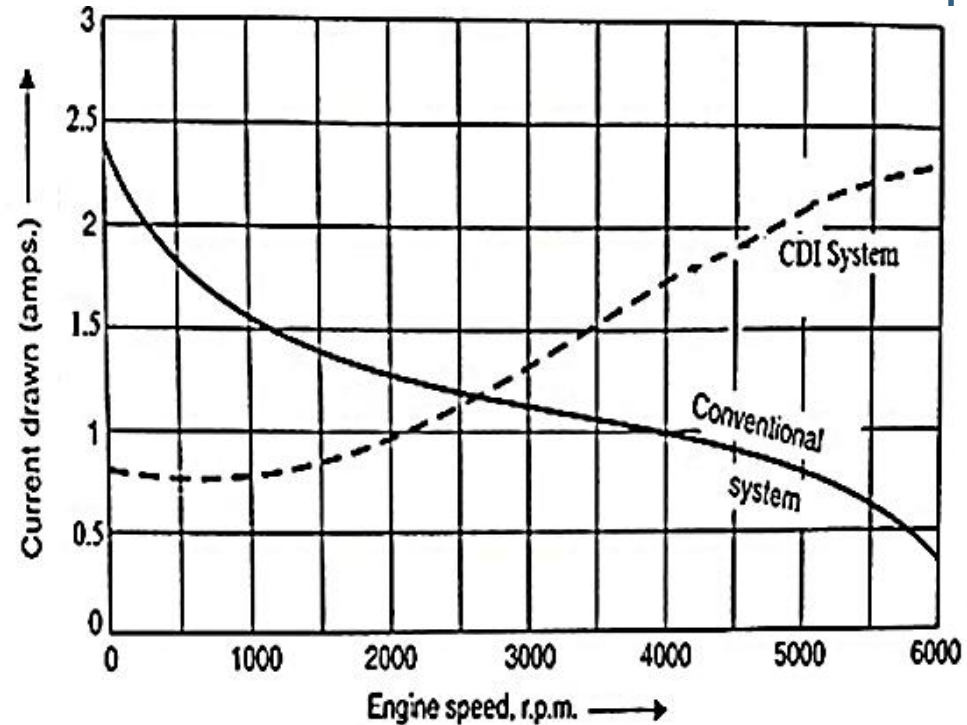
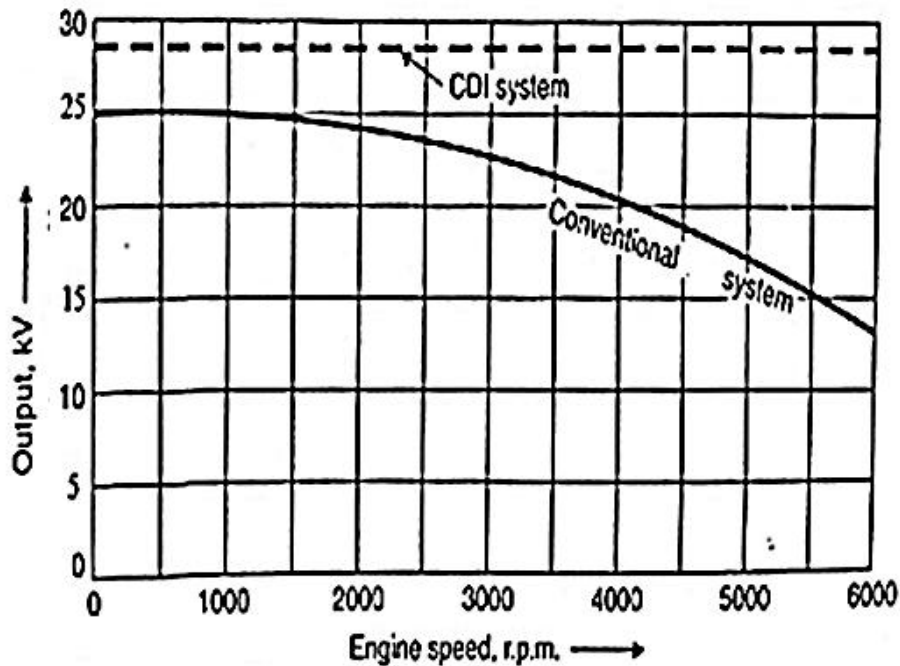



❑ Spark Plug:

- The main function of spark plug is to receive the high tension (voltage) current supplied by secondary winding of ignition coil and produce a high intensity spark across the spark gap. This spark is used for combustion of air-fuel mixture.
- The Fig. below shows the schematic diagram of spark plug. The first spark plug was used by Lenoir (in 1860) in his gas engine.
- The spark plug consists of contact terminal, metal case, insulator, seals and two electrodes viz., central electrodes and metal tongue (ground electrode) etc.
- The central electrode is connected to the contact terminal. Contact terminal is connected to the secondary winding carrying high voltage current.



- The central electrode is electrically isolated by using the porcelain insulator. The central electrode extends through the porcelain insulator into combustion chamber. Generally, the spark gap in spark plug in most of automobiles is in between 0.9–1.8 mm.
- As the high voltage current surges across the spark gap, it raises the temperature of the spark channel (gap) to 60,000 K. This heat in the spark channel results in expansion of ionized gases very quickly, like a **small explosion**. The sound of this explosion can be heard when observing the spark, similar to lightening.

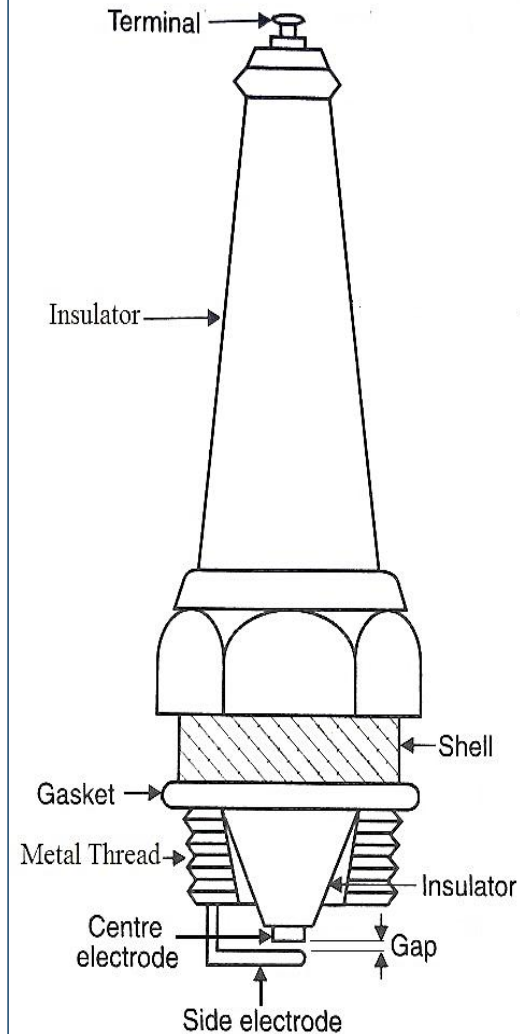

- There are variety of IC engines in use today, and each class poses various problems for the spark plug design from both the theoretical and practical points of view.
- The plug manufacturers have standardized a range of designs suitable for giving the best results under severe operating conditions, which are likely to be met in practice.
- The plug is likely to have the two extreme conditions of **pre-ignition and fouling** which should be avoided. For this reason, the plug must operate at certain definite temperature conditions for any given engine.
- Pre-ignition is likely to take place if any part of the plug reaches a temperature of about 900°C at the end of the compression stroke before sparking takes place.

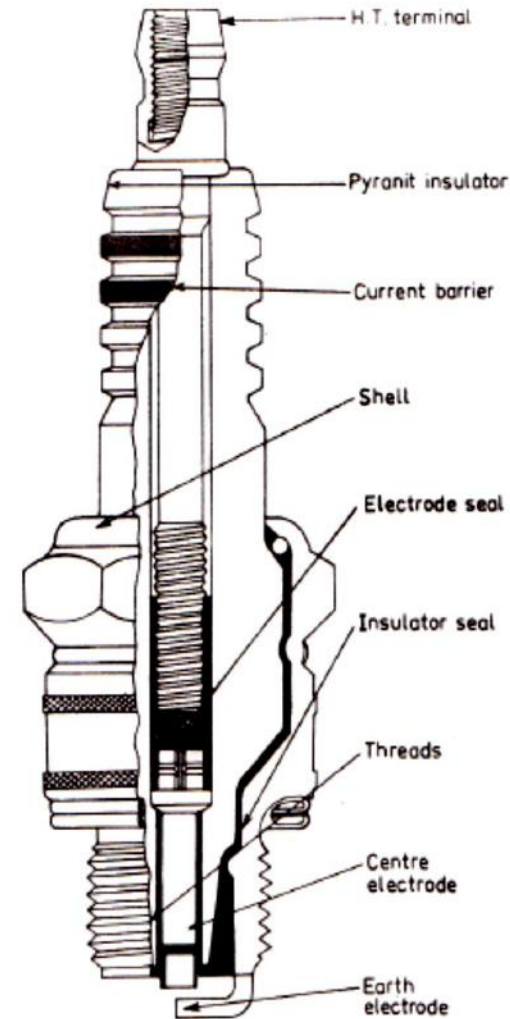

Fig. 8.1 Spark plug (courtesy : MICO).



- Fouling of the plug is likely to take place if the average temperature of the insulator over the cycle drops to the level of 400°C .
- To avoid these troubles, the optimum average cycle insulator temperature should be in the range of $450\text{-}850^{\circ}\text{C}$, which is high enough to burn off sufficient deposits to ensure freedom from fouling and at the same time the danger zone of pre-ignition is also avoided.



- There are engines having low efficiency and cool-running conditions and other having high efficiency and hot running such as sports and racing engines.
- The spark plug has to withstand widely varying heat developed during the cycle.
- This necessitates designing of the plugs in such a way that the plugs operate within the optimum temperature range as mentioned earlier. Therefore, the manufacturers have to regulate the rate at which the plugs transfer heat to the cooling system of the engine, keeping in view the insulator shape, the internal gas space variations, etc.
- It is referred to as the “heat range” of the spark plug.

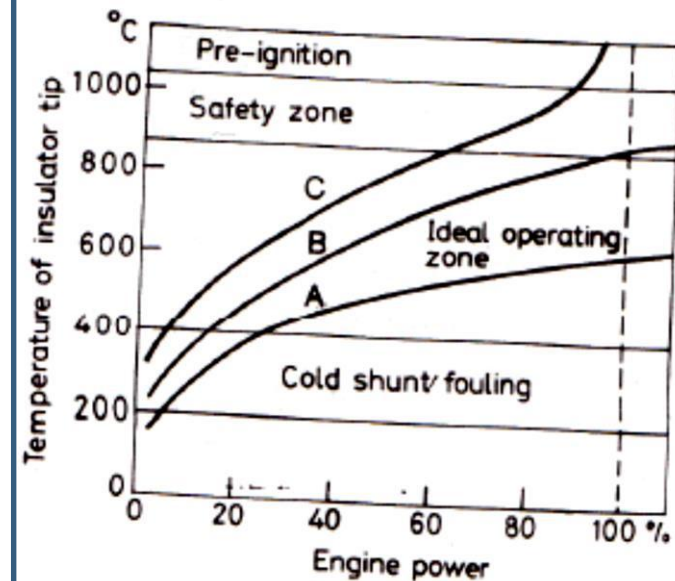

Fig. 8.2 Curves of temperature of insulator tips of a spark plug with different heat ranges (courtesy: MICO).



❑ Characteristics of Ideal Spark Plug:

1. Surety against Gas Leakage:

- It is one of the most important requirements of any spark plug because the leakage of gas results in loss of compression and in turn, loss of engine power.
- Further, overheating conditions are produced by the escaping gases resulting in damage to the spark plug.
- It may be remembered that at very high temperatures all electrical insulators become almost conductors.
- A leaky spark plug is likely to cause low insulation resistance and hence misfiring. It is therefore, very essential for the spark plug to be gas tight.
- Improvement in the materials of the insulators in recent days has overcome this difficulty.



2. Life:

- The life of a spark plug depends upon the careful selection and testing of the materials used in the manufacture of it. Further, it also depends on its design and assembly techniques.

3. Thread size and Reach of the spark plug:

- The most apparent difference in spark plug design is the variation in thread size and reach. The plug is selected by engine designer based on performance and operating conditions.
- It may be mentioned that the **engine efficiency depends upon the rate of propagation of the explosive wave** in the combustion chamber.
- For this reason if the electrodes of the plug are nearer the centre of the chamber, there are better chances of speeding up the complete combustion process. The plug should not be located either in a corner of the chamber or in a pocket.

- The thread size is often determined by operating conditions. Plugs subjected to high abuse applications require more breathing area. For this reason, the 18mm plug is used.
- In India, 14mm plugs are most commonly used for almost all applications.

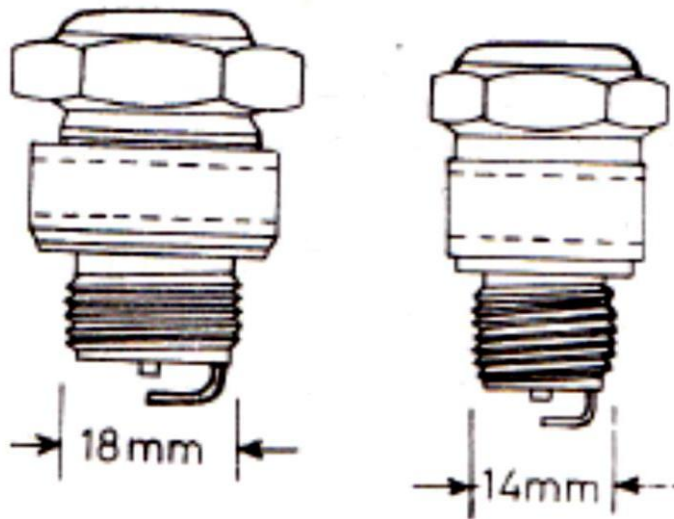

Fig. 8.3 Spark plug thread sizes (courtesy: MICO).

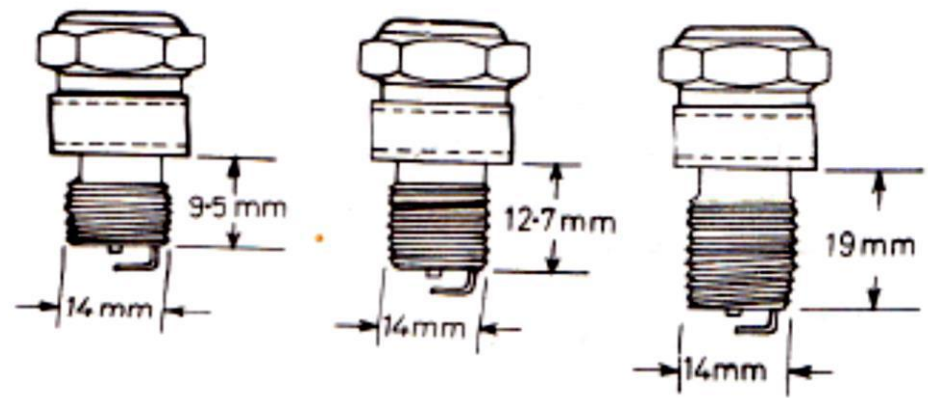

Fig. 8.4 Spark plug thread reaches (courtesy: MICO).



- Reach is the distance from the gasket seat to the end of the threads.
- It determines the position of spark in the combustion chamber, which is extremely important for proper flame propagation and efficient combustion of the fuel-air mixture.
- Engines with aluminum cylinder heads use longer reach plugs (12.7 mm or 19mm) to assure a better, stronger fit to the head.



4. Electrode Gap:

- Spark plugs differ from one another not only in heat range or reach but also in electrode gap.
- The electrode gap is the shortest distance between the earth electrode and center electrode.
- It is determined by the vehicle and engine manufacturers, the decisive factors being the influence of the fuel air mixture on the behavior of the engine under part load, during idling and sudden acceleration.
- The electrode gap should be as narrow as possible, to minimize the amount of high voltage necessary for ignition.
- As it is constantly enlarged during operation due to action of the spark erosion and chemical corrosion, the ignition voltage requirement increases until the voltage reserve of the ignition system is finally exhausted.

- *Electrode gap too wide:-* the available voltage soon becomes inadequate and misfiring will occur.
- *Electrode gap too narrow:-* the engine would run unevenly, especially when operating in one of critical phases (Partial load, idling etc.)

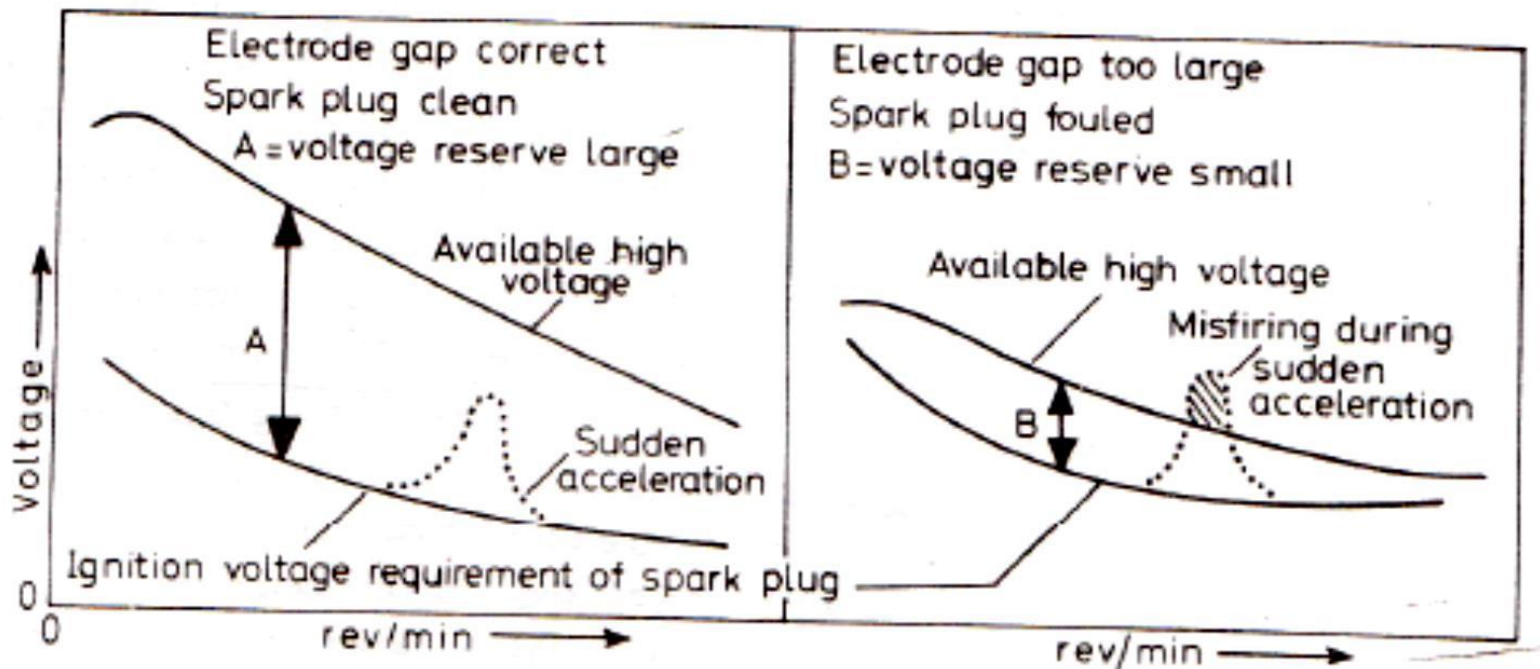

Fig. 8.6 Curves of ignition voltage requirements of spark plug (courtesy: MICO).



5. Rust and Corrosion:

- The frequent exposure of the plugs to the atmospheric conditions and the high operating temperatures are likely to lead to rust and corrosion.
- For this purpose, it is the usual practice to use steel as the material of the shell and then subject it to a rust-proofing process such as **zinc plating**.
- The shells of MICO spark plugs are **plated with nickel**. It reduces corrosion and has three times the melting point of zinc.

6. Current Leakage and Electrical Puncture:

- To guard against current leakage and electrical punctures, the material used for the insulator is such that it has the best possible dielectric strength.
- Further, the insulator is designed in such a way that it has adequate sections and sample creeping surfaces.



7. Electrodes' Electrical Characteristics:

- The sparking voltage is dependent on the distance the electrodes are from each other and their shape, in addition to other factors.
- Sharp-pointed electrodes should be avoided since the gap erosion will be extremely high.
- The material used should have high resistance to spark erosion. The electrodes should be strong enough to suffer mechanical damage.



8. Misfiring or Short Circuiting:

- In order to have freedom from short circuiting the air gap between the electrodes should not be less than 0.375mm.
- An average setting of the gap is of the order of 0.50mm but gaps as high as 0.75-0.875 mm are also used.
- High gaps are particularly suitable where petrol economy through the use of weak mixture is desired.
- The exact gap depends on no. of factors such as **mixture ignition requirements, voltage output from the ignition coil** and the amount of gap erosion giving a sufficient period of time before removal of the plugs and their gaps re-setting becomes necessary.

❑ Heat Ranges of Plugs:

- It should be borne in mind that for each design of engine, there is a certain temperature range for the plug exposed portion at which it will have satisfactory operation and remain free from carbon deposits.
- The principal factors which influence the choice of plug for each engine are **combustion chamber design, compression ratio, water cooling passages, location of plug.**
- Hot plug has a longer heat path giving delayed cooling than the cold plug. The hot plugs have much longer insulator nose than the cold plugs.

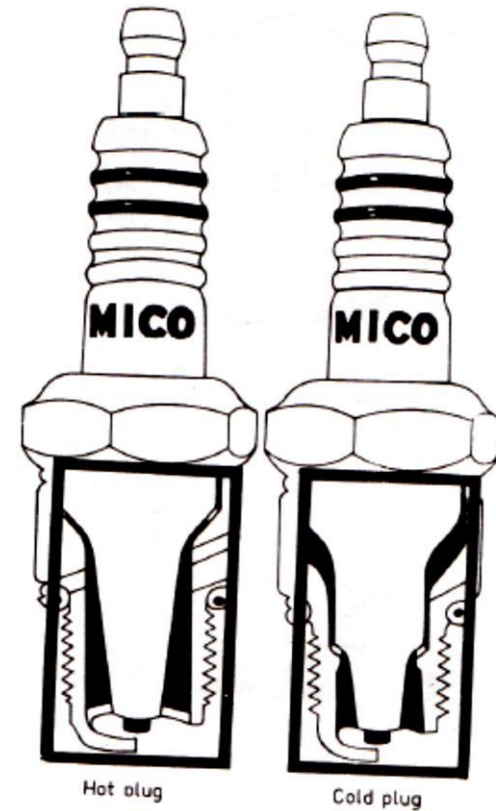

Fig. 8.15 Hot and cold plugs (courtesy: MICO).

- The manufacturers of spark plugs have developed and produced a range of spark plugs that covers the special range of temperature requirements of all motor-cycles and vehicle engines satisfactory.
- The plug shown at No.8 is hottest and suitable for coldest running engine.
- The plug shown at No.1 is coldest and hence suitable for hottest running engine.

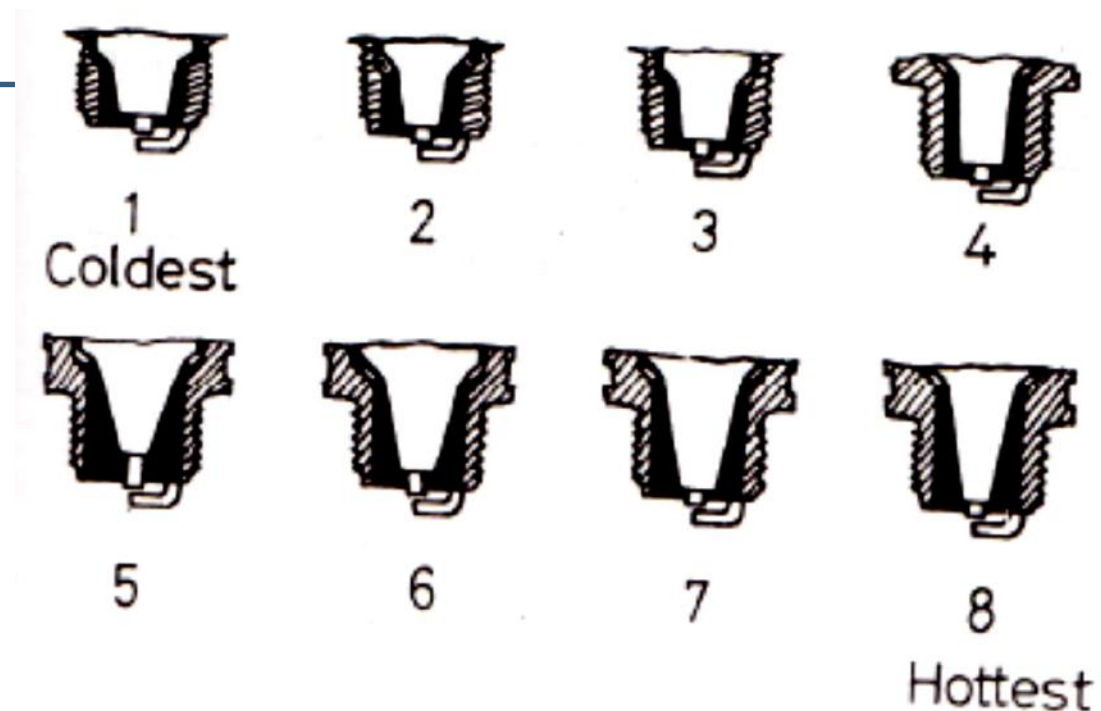

Fig. 8.16 Spark plugs of different heat ranges.