



Unit – VI

Automatic Transmission

By,
Mr. A J Bhosale
Asst. Professor
Dept. of Automobile Engineering
Govt. College of Engineering and Research, Avsari (Kd)



❖ Syllabus:-

- Fluid Flywheel: Operating principle, Construction and working of fluid flywheel, Characteristics, Advantages & limitations of fluid coupling, Torque convertor: construction and working of torque converter, Performance characteristics, Comparison with conventional gear box.
- Epicyclic Gear Boxes : Simple epicyclic gear train, Gear ratios, Simple & compound planet epicyclic gearing, Epicyclic gear boxes, Wilson epicyclic gear train - Construction and operation, Advantages, Clutches and brakes in epicyclic gear train, compensation for wear, performance characteristics.
- Principle of semi automatic & automatic transmission, Hydramatic transmission, Fully automatic transmission, Semi automatic transmission, Hydraulic control system,
- Continuous variable transmission (CVT) – operating principle, basic layout and operation, Advantages and disadvantages.

❖ Introduction

- When we want to transfer the rotation energy or torque of one shaft to another, we have to connect those two shafts with such a arrangements which can transfer the power with maximum efficiency and as per need.
- In above kind of situations, "The couplings" is used.
- The coupling is device which connects the driving and driven shaft and also transfer the power.
- A Fluid coupling is used for transmitting power or torque from one to another shaft with the help of oil (fluid).
- **Without MECHANICAL connection of two shafts.**

Fluid coupling

principle of operation

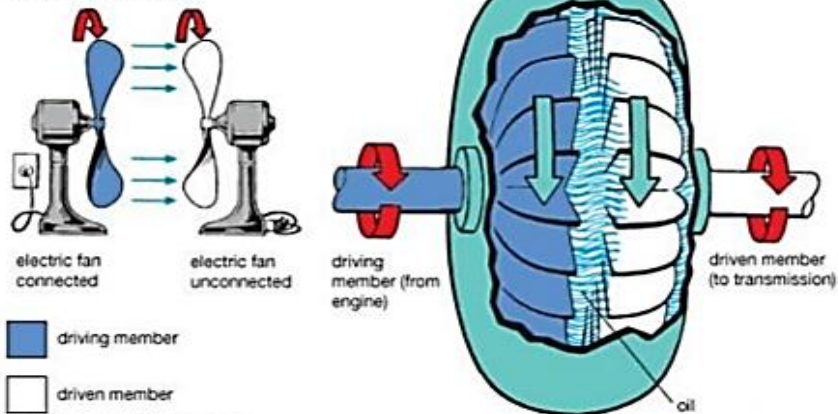

© 2010 Encyclopedia Britannica, Inc.



❖ Fluid Flywheel:

- The hydrokinetic fluid coupling, also called as a fluid flywheel, uses two saucer-shaped discs, an input impeller (pump) and an output turbine (runner). Both impeller and turbine are cast with a number of flat radial vanes (blades) to direct the flow path of the fluid (Fig.1).
- The hydrokinetic coupling works on the principle of relative slip between the input and output member cells facing to each other, and the continuous alignment and misalignment of the vortex flow path, created by pairs of adjacent cells, with different cells.

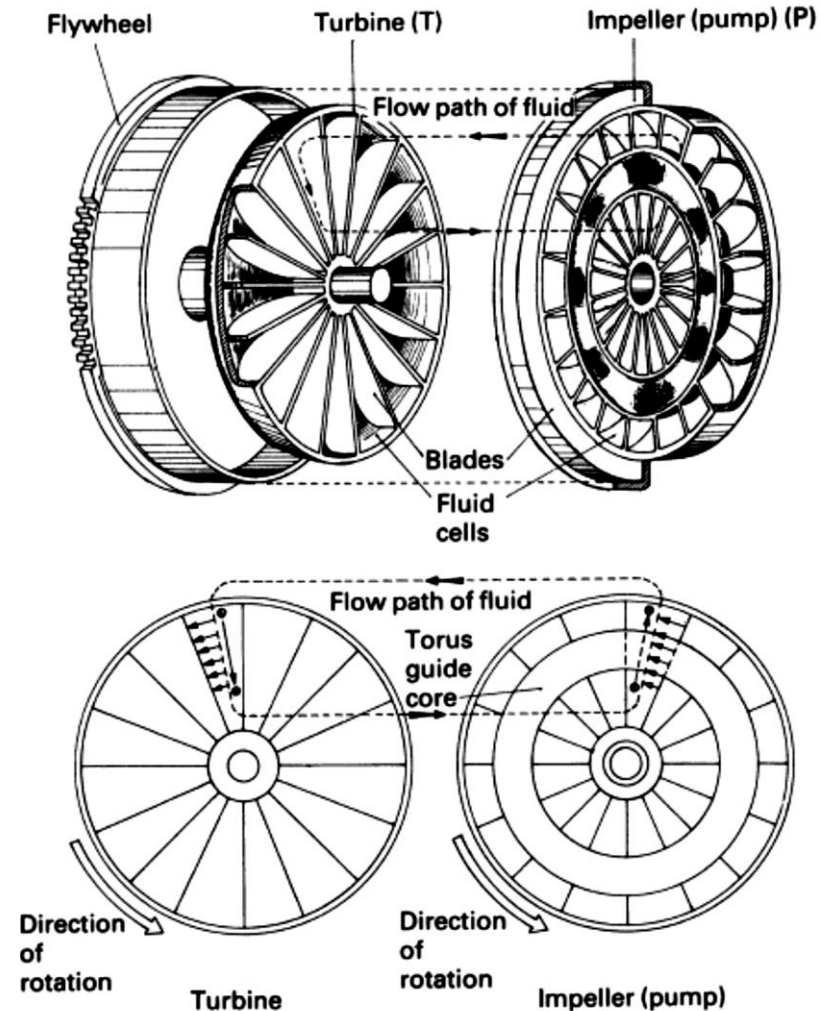

Fig. 1



- If the impeller and turbine have equal numbers of cells, the relative cell alignment of all the cells occurs together so that a jerky transfer of torque from the input to the output drive occurs.
- **With unequal numbers of cells in the two half members, the alignment of each pair of cells at any one instant is slightly different.**
- **This causes the impingement of fluid from one member to the other in various stages of circulation, so that the coupling torque transfer becomes progressive and relatively smooth.**
- The two half members are put together to obtain vortex flow of the fluid.

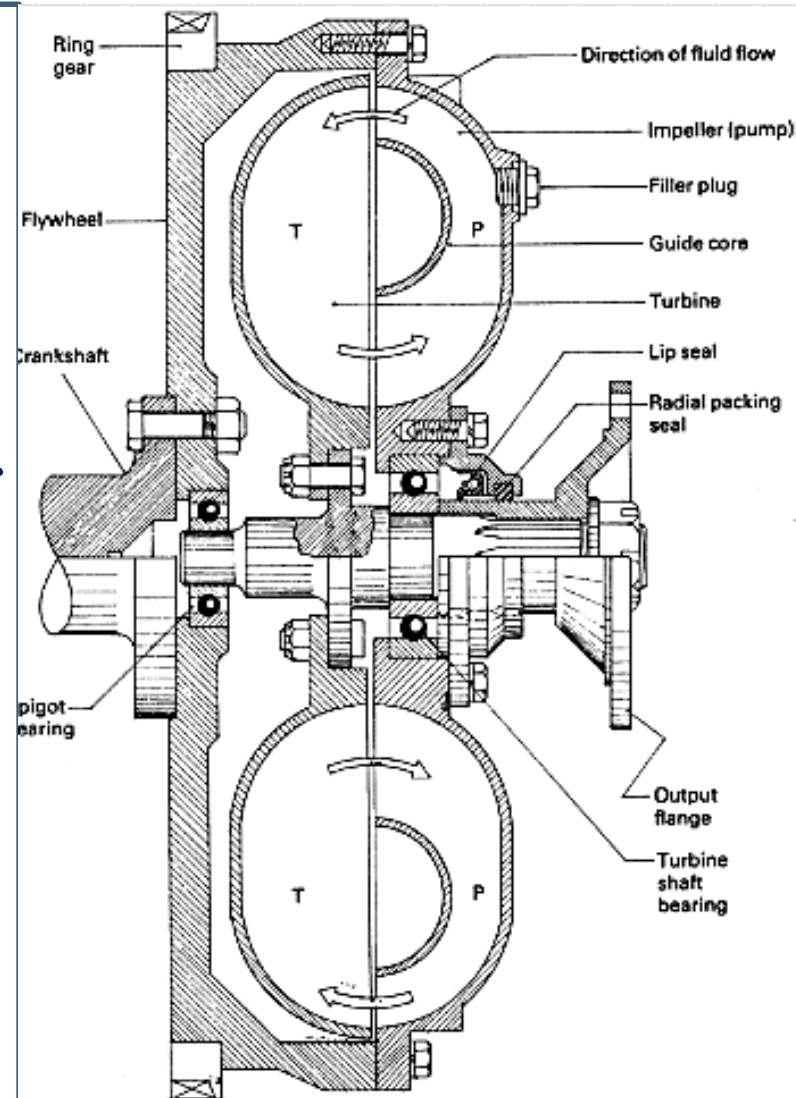
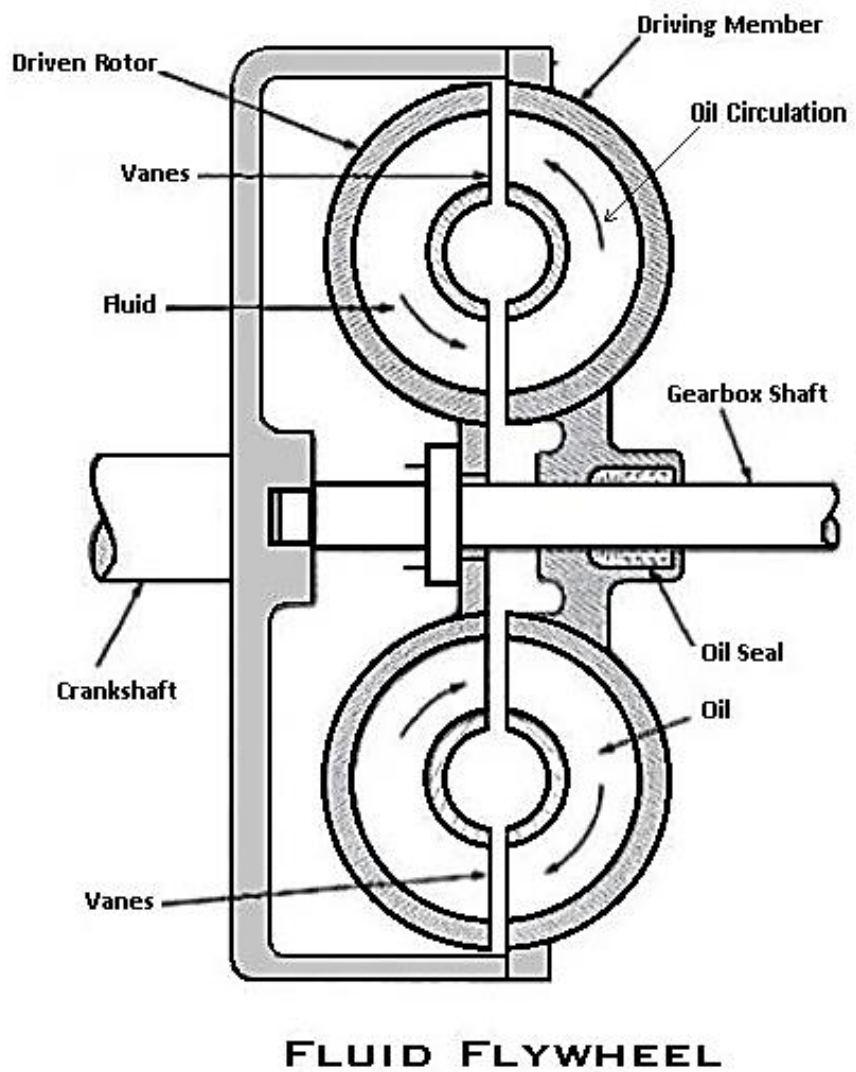

Fig.2



FLUID FLYWHEEL



CASING

RUNNER

IMPELLER



- In the earlier designs, normally a hollow core or guide ring (sometimes called as the torus) was inserted at the centre of rotation within both half-members to initiate early fluid circulation once the relative rotation of the members has been established.
- However, these couplings produced considerable drag torque during idling. Consequently only one core guide was used on the impeller member (Fig.2) to reduce turbine drag at low speeds.
- In the latest design these cores are totally eliminated even to reduce fluid interference in the higher speed range. As a result the degree of slip for a given amount of transmitted torque (Fig. 3 below) is also reduced.

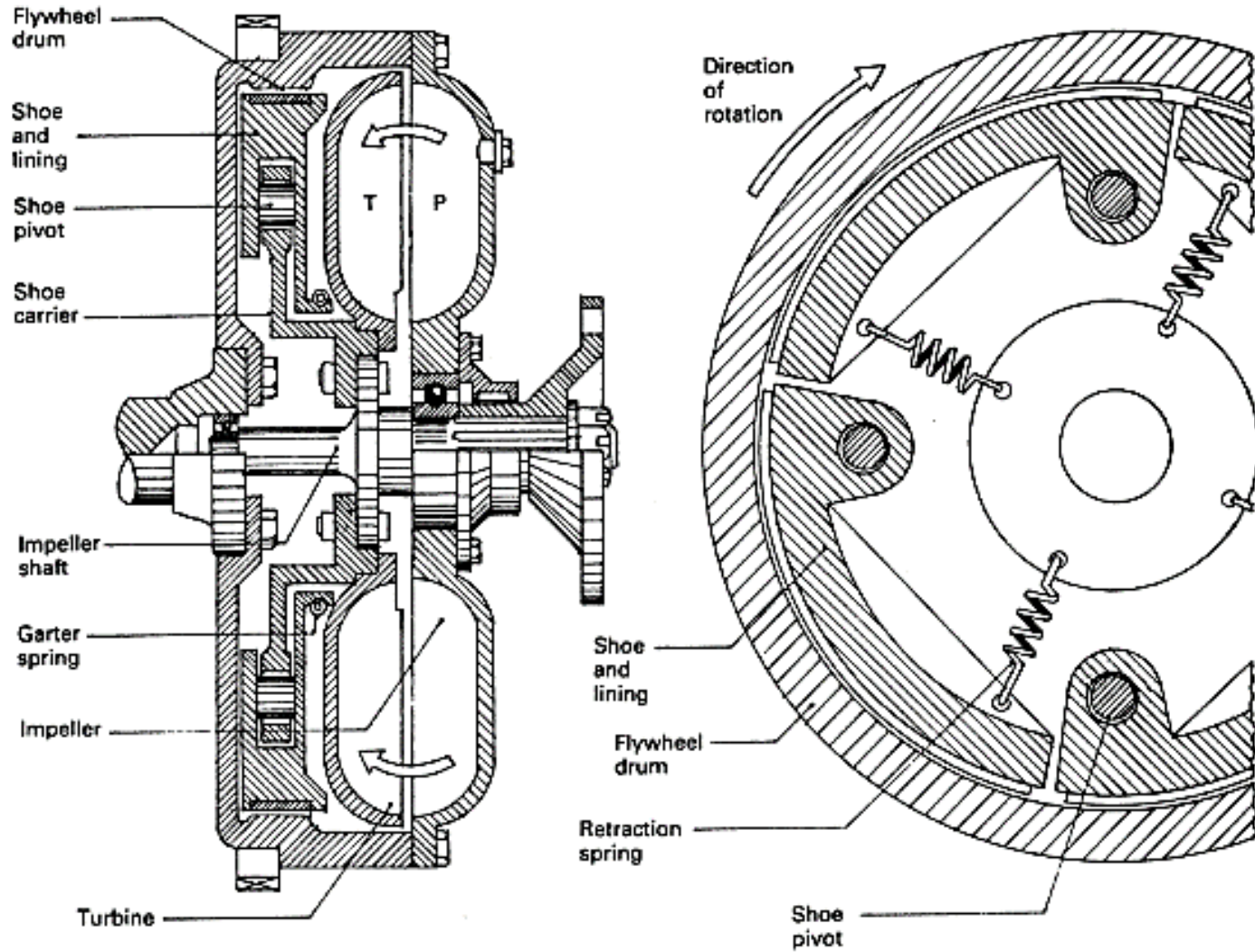
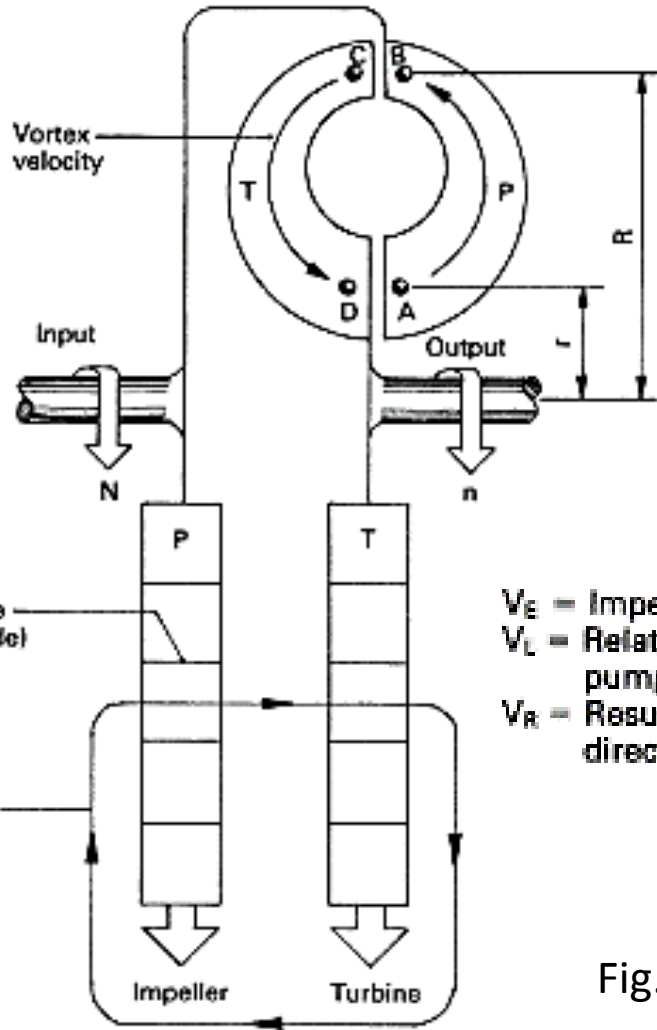

Fig. 3



❖ Principle of Operation: (Fig.4)

- During starting of the engine, the rotation of the impeller (pump) causes the working fluid trapped in its cells to rotate with it and due to centrifugal force, the fluid is pressurized and flows radially outwards.
- To understand the principle of the hydrokinetic coupling, circulation of a small fluid particle between one set of impeller and turbine vanes at various points A, B, C and D is considered as shown in Fig. 4.
- When the engine is started and hence the impeller is rotated, a particle of fluid at point A experiences a centrifugal force due to its mass and radius of rotation r , so acquires some kinetic energy. This particle of fluid is forced to move outwards to point B at radius, R , so that it is subjected to relatively more centrifugal force thereby acquiring a greater amount of kinetic energy.



V_E = Impeller exit velocity
 V_L = Relative linear velocity of both pump and turbine
 V_R = Resultant effective velocity and direction of fluid

Θ_1 Smaller
 V_L Large
 Stalled turbine

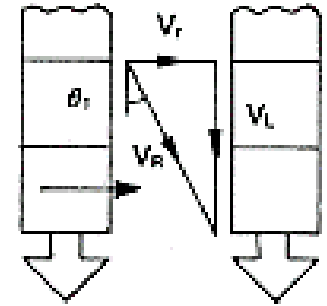

Θ_2 Intermediate
 V_L Decreases
 Medium speed

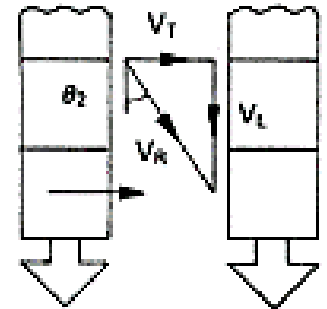

Θ_3 Bigger
 V_L Smaller
 High speed

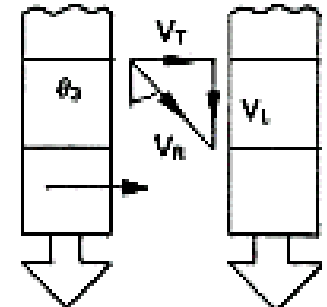

Fig. 4 Principle of Fluid Coupling

Smaller Θ , Higher Thrust Force



- At this outermost position, due to high kinetic energy, the particle is ejected from the mouth of the impeller cell, and is forced to enter one of the outer turbine cells at point C.
- During this process the particle reacts with the turbine vanes and imparts some of its kinetic energy to the turbine wheel. Continuous fling of fluid particles across the junction between the impeller and turbine cells force the first fluid particle in the slower moving turbine member with reduced centrifugal force, to move inwards to point D.
- In the process of moving from R to r, the fluid particle imparts most of its kinetic energy to the turbine wheel, which is subsequently converted into propelling effort and motion.
- The fluid under circulation contains two motions; firstly it is circulated by the impeller around its axis and secondly it circulates round the cells in a vortex motion.



- This circulation of fluid continues till the centrifugal force possessed by the fluid in the faster moving impeller supersedes the counter centrifugal force acting on the fluid in the slower moving turbine member.
- The velocity of the fluid around the axis of rotation of the coupling increases as it flows radially outwards in the impeller cells. On the other hand the fluid velocity decreases when it flows inwards in the turbine cells and hence gives up its kinetic energy to the turbine.
- Therefore transference of energy from the input impeller to the output turbine takes place in the process, without any torque multiplication.



❖ Efficiency and Torque Capacity

- The fluid coupling efficiency is defined as the ratio of the power available at the turbine to the power supplied to the impeller. The difference between input and output power, besides the power lost by fluid shock, friction and heat, is mainly due to the relative slip between the input and output members (Fig. 5).
- The percentage slip is defined as the ratio of the difference in input and output speeds, $(N-n)$ to the input speed, N multiplied by 100.

i.e.
$$\% \text{ slip} = \frac{N - n}{N} \times 100$$
 $N = \text{i/p speed, } n = \text{o/p speed}$

- The percentage slip is greatly dependent on the engine speed and load condition of the output turbine (Fig. 6).
- A percentage of slip must always be present to create sufficient rate of vortex circulation necessary to impart energy from the impeller to the turbine. The maximum coupling efficiency is about 98% under light load high rotational speed conditions, and this is considerably reduced with increase, in turbine output or decrease in impeller speed.

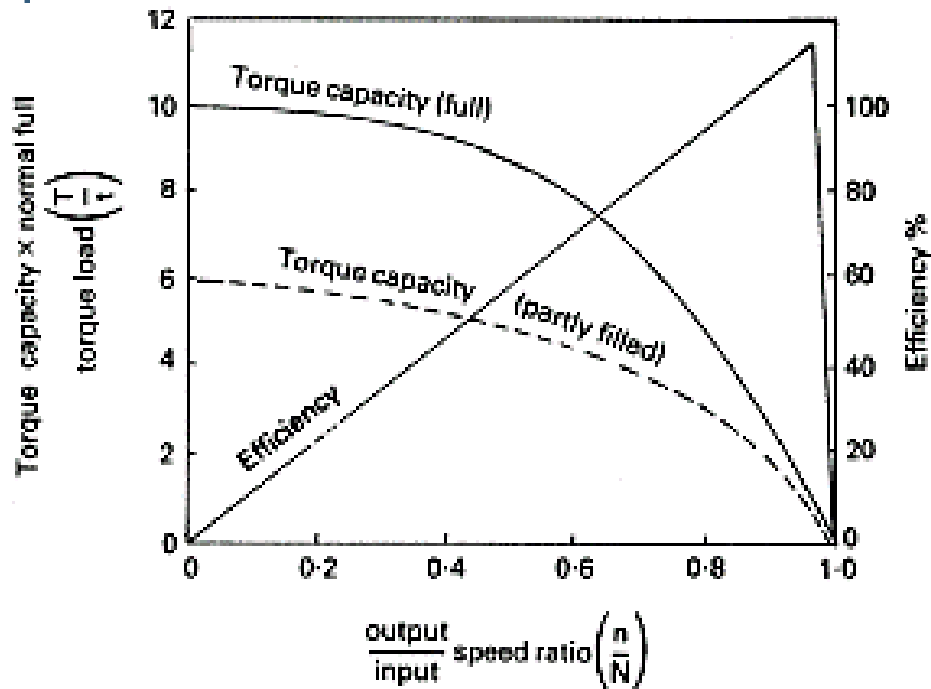

Fig. 5. Relationship of torque capacity, speed ratio and efficiency for fluid coupling.

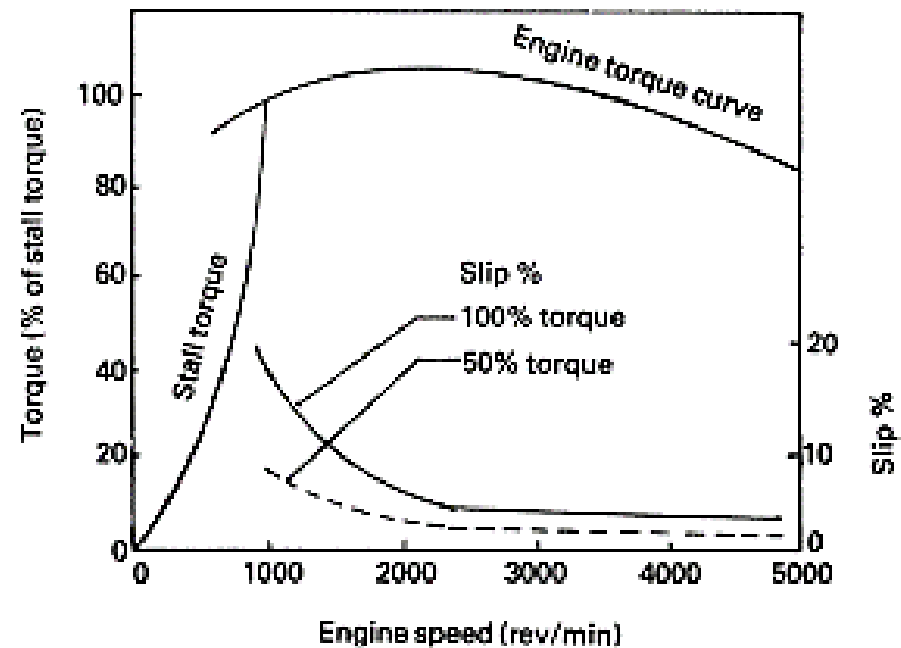

Fig. 6. Relationship between engine speed, torque and slip for fluid coupling.



- As the output torque demand increases, more slip occurs, which increases the vortex circulation velocity so that more kinetic energy is imparted to the output turbine member, thereby raising the torque capacity of the coupling.
- The torque transmitting capacity of fluid coupling, T for a given slip varies as the fifth power of the impeller internal diameter, D and as the square of its speed, N . Hence, $T \propto D^5 N^2$
- Additionally, torque transmitting capacity also depends on the amount of fluid circulating between the impeller and turbine. Raising or lowering the fluid level in the coupling increases or decreases the torque, which can be transmitted to the turbine.
- An additional feature to these types of coupling is that if the engine tends to stall due to overloading when the vehicle is accelerated from rest, the vortex circulation immediately slows down, preventing further torque transfer until the engine's speed has recovered.



❖ Advantages of a Fluid Coupling

- The power transmission is free from vibration and noises.
- The power transmission is smooth in extreme conditions.
- Overload Protection.
- The Maximum torque can be adjusted by varying the amount of oil filled in the casing.

❖ Disadvantages of a Fluid Coupling

- There is always slip.
- Fluid coupling can not develop torque when the driving shaft and driven shaft are rotating at same angular speed.
- Under stalling condition, the coupling dissipates energy as heat it may lead to damage.



❖ Torque Converter :

○ Introduction

- Torque converter is generally a type of fluid coupling (but also being able to multiply torque) that is used to transfer rotating power from a prime mover, such as an internal combustion engine or electric motor, to a rotating driven load.
- The torque converter normally takes the place of a mechanical clutch in a vehicle with an automatic transmission, allowing the load to be separated from the power source. It is usually located between the engine's flywheel and the transmission.
- The key characteristic of a torque converter is its ability to multiply torque when there is a substantial difference between input and output rotational speed, thus providing the equivalent of a reduction gear.



- The torque converter works in conjunction with the transmission to match the engine output to the torque requirements (load) at the drive wheels
- In a lighter duty application the converter replaces the mass of the flywheel and is connected to the crankshaft with the use of a flex-plate, a flexible metal disc which allows the torque converter to expand as it is loaded and multiplying torque. through the entire operating range of the vehicle.
- In a heavy-duty application a flywheel must still be used to generate sufficient mass to provide the inertia for the engine to run smoothly and will have one or more flex-plates attached to the flywheel and the torque converter.



- The Three element torque converter coupling is comprised of an input impeller casing enclosing the output turbine wheel. There are about 26 and 23 blades for the impeller and turbine elements respectively.
- Both of these elements and their blades are fabricated from low carbon steel pressings. The third element of the converter called the stator is usually an aluminum alloy casting which may have something in the order of 15 blades.
- The working fluid within a converter when the engine is operating has two motions:
 - Fluid trapped in the impeller and turbine vane cells revolves bodily with these members about their axis of rotation.
 - Fluid trapped between the impeller and turbine vane cells and their central torus core rotates in a circular path in the section plane, this being known as its ***Vortex Motion***.
- When the impeller is rotated by the engine, it acts as a centrifugal pump drawing in fluid near the center of rotation, forcing it radially outwards through the cell passages formed by the vanes to the impeller peripheral exit.
- Here it is ejected due to its momentum towards the turbine cell passages and in the process at an angle against the vanes, thus imparting torque to the turbine member.



- The fluid in the turbine cell passages moves inwards to the turbine exit. It is then compelled to flow between the fixed stator blades. The reaction of the fluid's momentum as it glides over the curved surfaces of the blades is absorbed by the casing to which the stator is held and in the process it is redirected towards the impeller entrance.
- It enters the passages shaped by the impeller vanes. As it acts on the drive side of the vanes, it imparts a torque equal to the stator reaction in the direction of rotation.
- It therefore follows that the engine torque delivered to the impeller and the reaction torque transferred by the fluid to the impeller are both transmitted to the output turbine through the media of the fluid.
- **i.e. Engine Torque + Reaction Torque = Output Turbine Torque**



Blades on Impeller- 26 }
Blades on Turbine- 23 } Low Carbon Steel Pressing

Blades on Stator- 15- Aluminum Alloy Casting

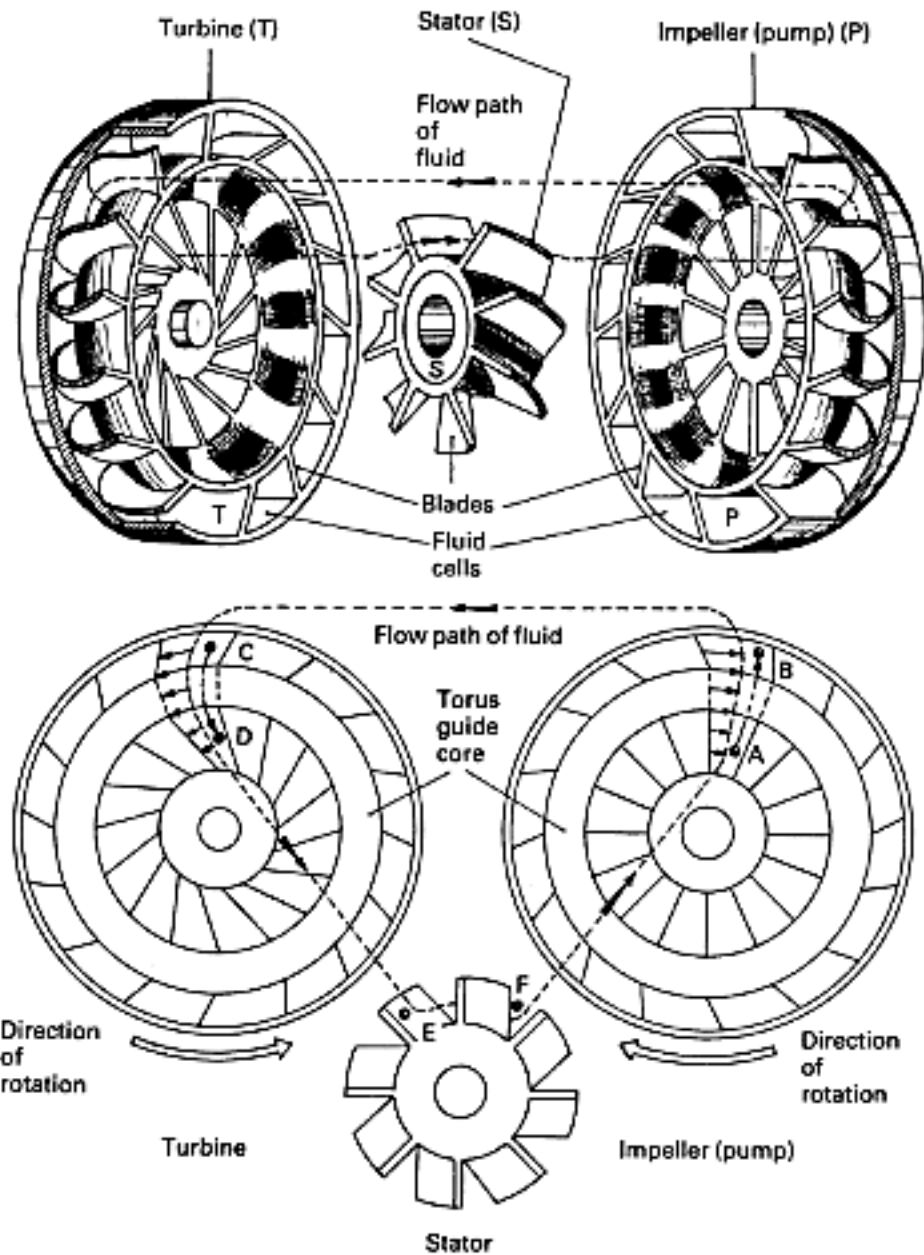

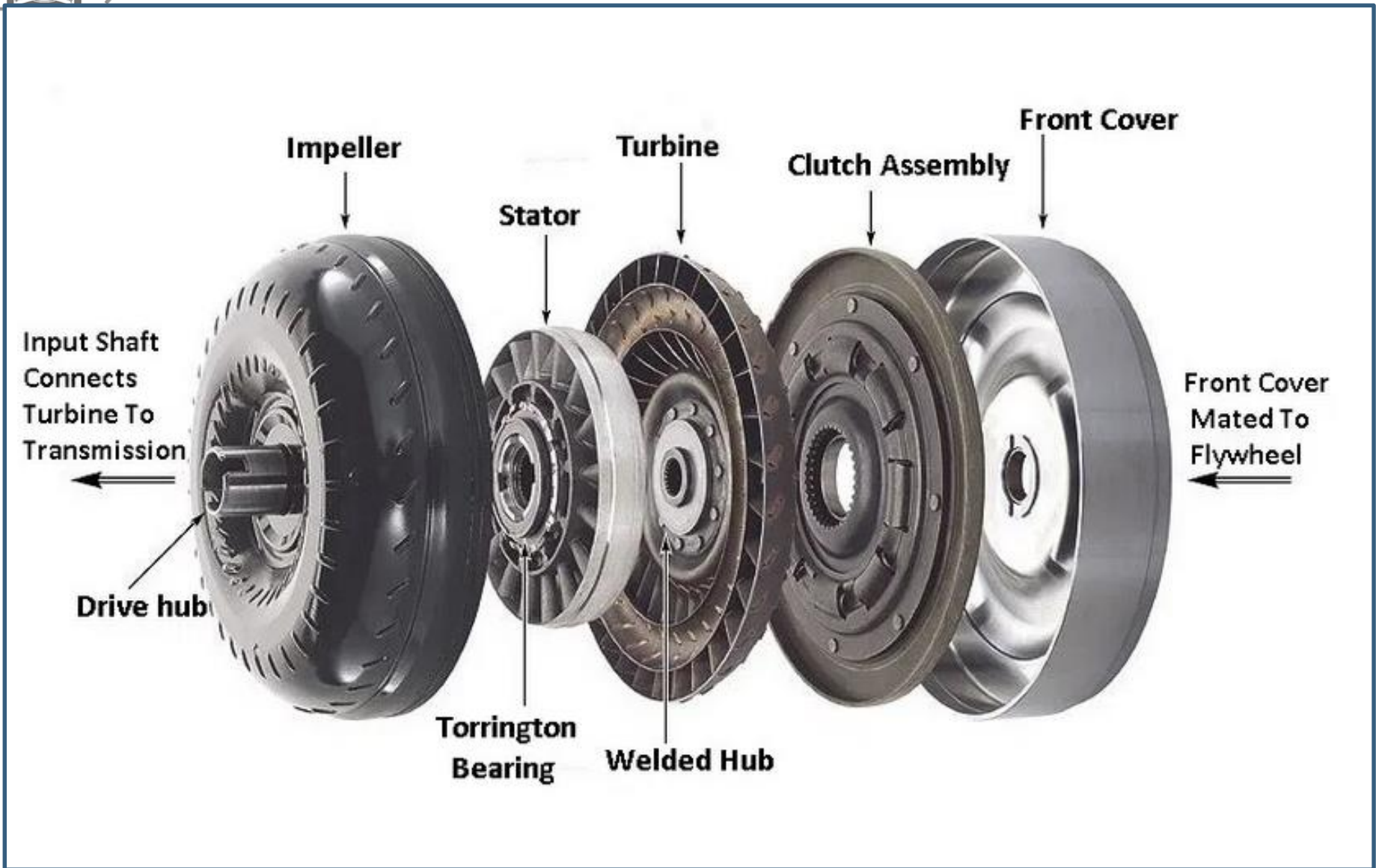



Components:

1. Pump or impeller:

- Impeller is attached to the inside of the rear half of the torque converter shell or housing.
- This is the element that forces transmission fluid against turbine to move the vehicle, both pump and impeller are used but by using the term impeller it will not be confused with the hydraulic pump of the transmission.
- Since the impeller is attached to the converter housing and it in turn is connected to the engine, whenever the engine is running the impeller turns with its attached to the inside of the rear half of the torque converter shell or housing.
- This is the element that forces transmission fluid against turbine to move the vehicle, both pump and impeller are used but by using the term impeller it will not be confused with the hydraulic pump of the transmission.
- Since the impeller is attached to the converter housing and it in turn is connected to the engine, whenever the engine is running the impeller turns with it.





2. Turbine:

- The turbine sits inside the converter housing but is not mechanically connected to it.
- The turbine is the only member or part of the torque converter that is attached to the transmission.
- The turbine is splined to the transmission input-shaft and causes it to rotate when conditions are correct.





3. Stator:

- The stator is key to torque multiplication and without it the torque converter would be little more than a fluid coupling.
- The stator is usually a two piece unit consisting of an inner hub and an outer wheel.
- The inner hub is splined to a shaft that projects from the front pump of the transmission called either the stator support shaft or the stator ground shaft.





- Either term is acceptable but the important point to note is that this shaft does not turn it is solidly connected to the front of the transmission and serves to anchor the stator inner hub.
- The outer wheel of the stator is connected to the inner hub by a one way type clutch, either roller type or sprag type.
- This arrangement allows the stator to freewheel in one direction of rotation but it will lock up and remain stationary in the other direction, the necessity for this will be explained as we go on.
- Many different types of stators are used for many different vehicle and vocational applications such as fixed stators that do not freewheel and variable pitch stators that can change the torque multiplication factor to adapt to certain operating conditions.

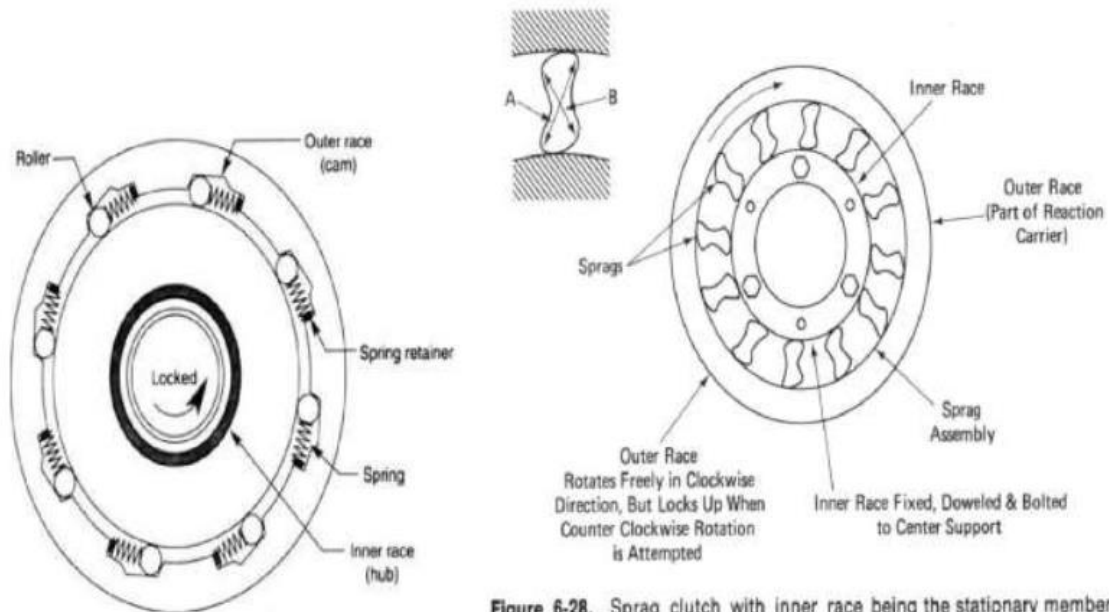

Figure 6-28. Sprag clutch with inner race being the stationary member.



❖ Functions of torque converter

- A torque converter has three stages of operation:-

1. Stall

- The prime mover is applying power to the impeller but the turbine cannot rotate. For example, in an automobile, this stage of operation would occur when the driver has placed the transmission in gear but is preventing the vehicle from moving by continuing to apply the brakes.
- At stall, the torque converter can produce maximum torque multiplication if sufficient input power is applied (the resulting multiplication is called the stall ratio).
- The stall phase actually lasts for a brief period when the load (e.g., vehicle) initially starts to move, as there will be a very large difference between pump and turbine speed.

2. Acceleration

- The load is accelerating but there still is a relatively large difference between impeller and turbine speed.
- Under this condition, the converter will produce torque multiplication that is less than what could be achieved under stall conditions.
- The amount of multiplication will depend upon the actual difference between pump and turbine speed, as well as various other design factors.

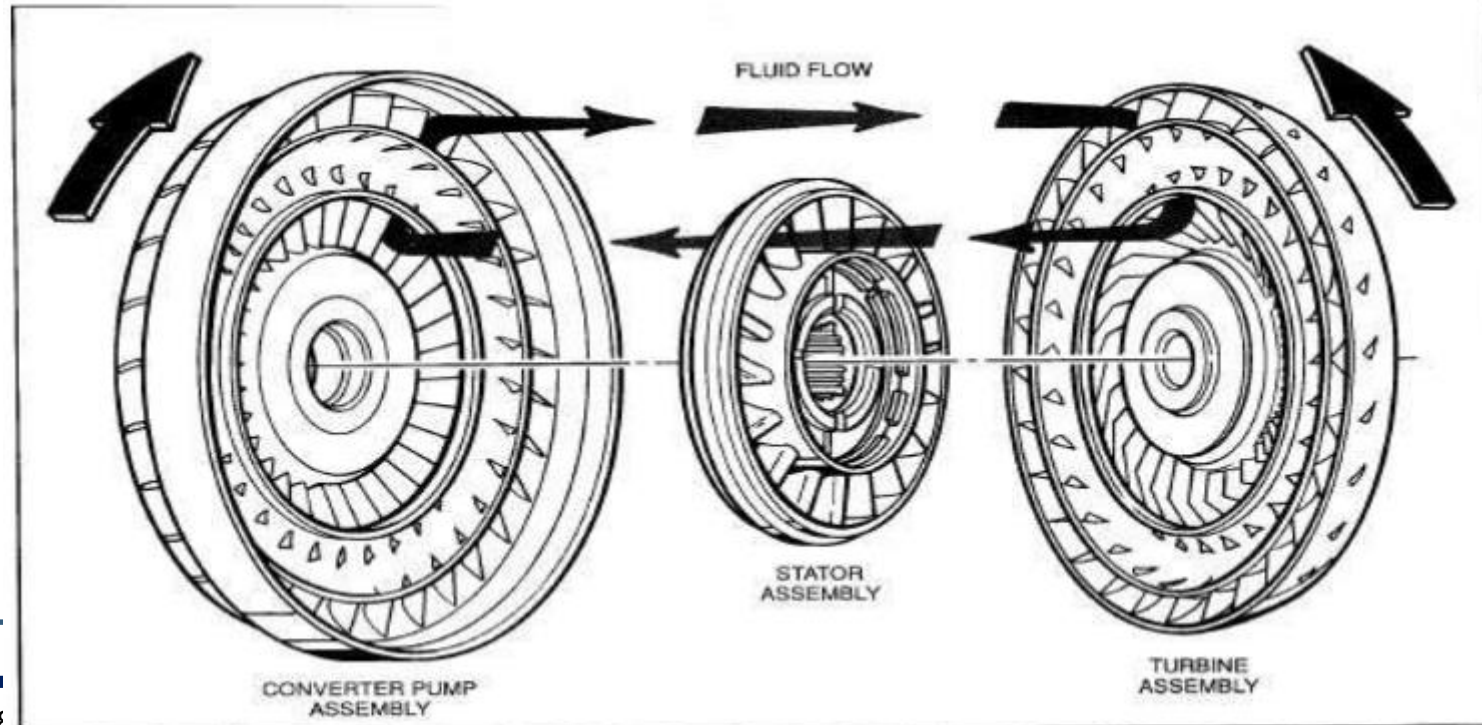
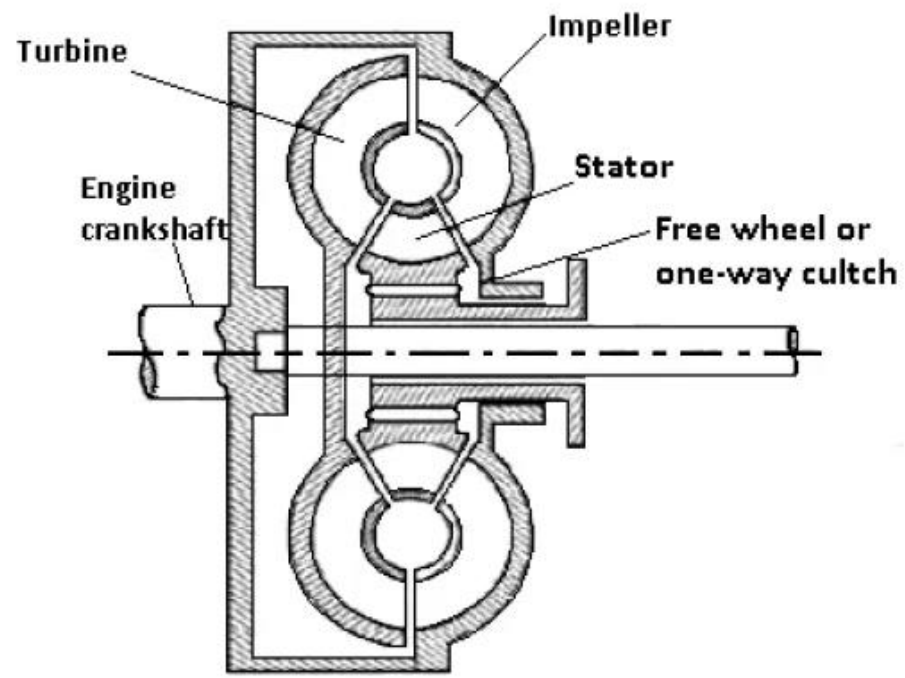
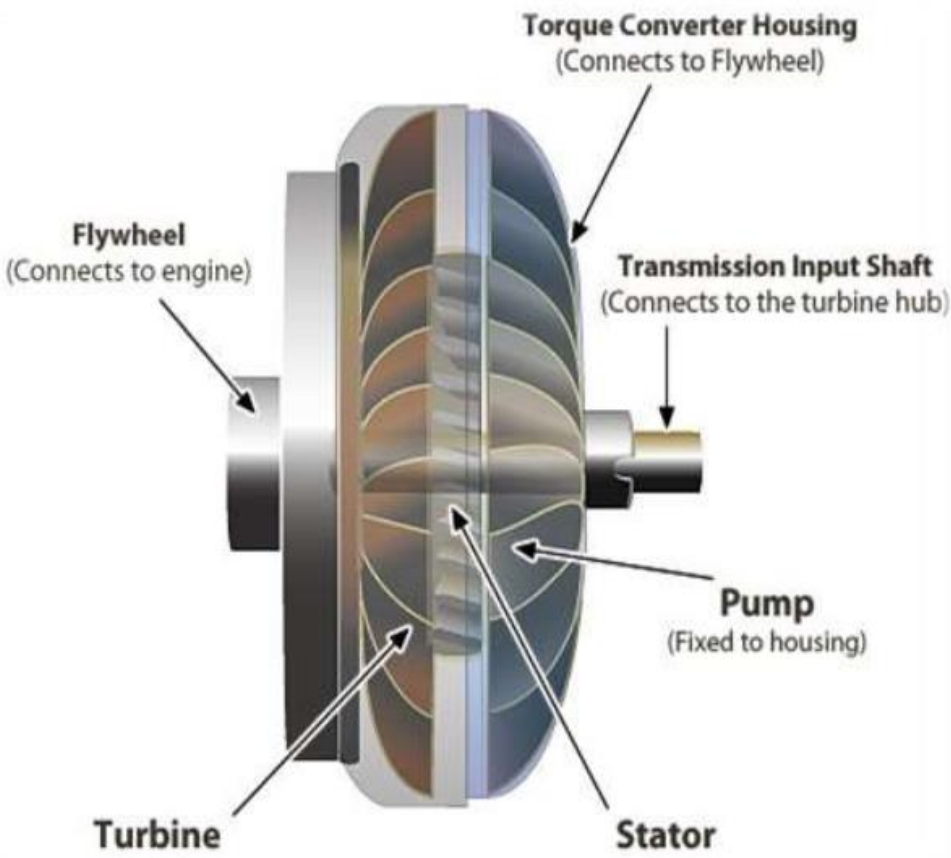

Figure 3 Torque Converter Fluid Flow



Torque converter



3. Coupling:

- The turbine has reached approximately 90 percent of the speed of the impeller.
- Torque multiplication has essentially ceased and the torque converter is behaving in a manner similar to a simple fluid coupling.
- In modern automotive applications, it is usually at this stage of operation where the lock-up clutch is applied, a procedure that tends to improve fuel efficiency.

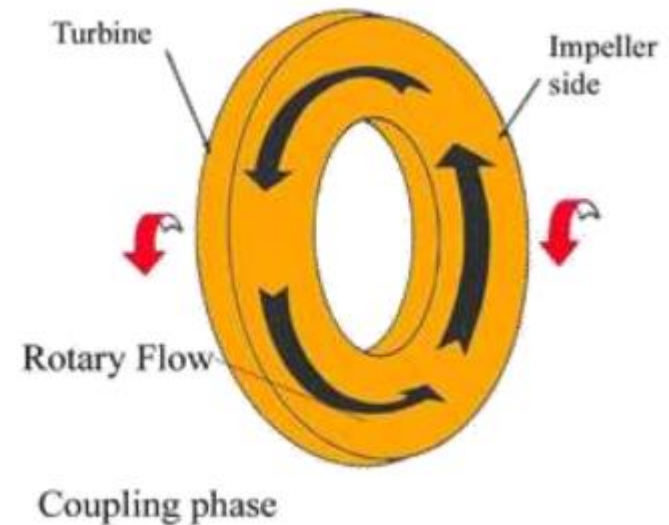



❖ Converter in and out oil circuits:

- Converter in circuit starts at Main Pressure Regulator Valve (MPRV). Pressurized fluid flows into converter in between the outside of the stator support shaft and the inside of oil pump drive hub attached to the back of the converter.
- A torque converter pressure relief valve controls the maximum converter working pressure. In light duty vehicles this pressure would be near 70 to 80 PSI, in heavy duty vehicles this pressure can be as high as 200 to 250 PSI.
- Some transmissions use this oil circuit for partial transmission lubrication most transmissions will have a drain-back valve of some kind to prevent fluid from draining back to the transmission sump through the front lube circuit when the engine is shut off.

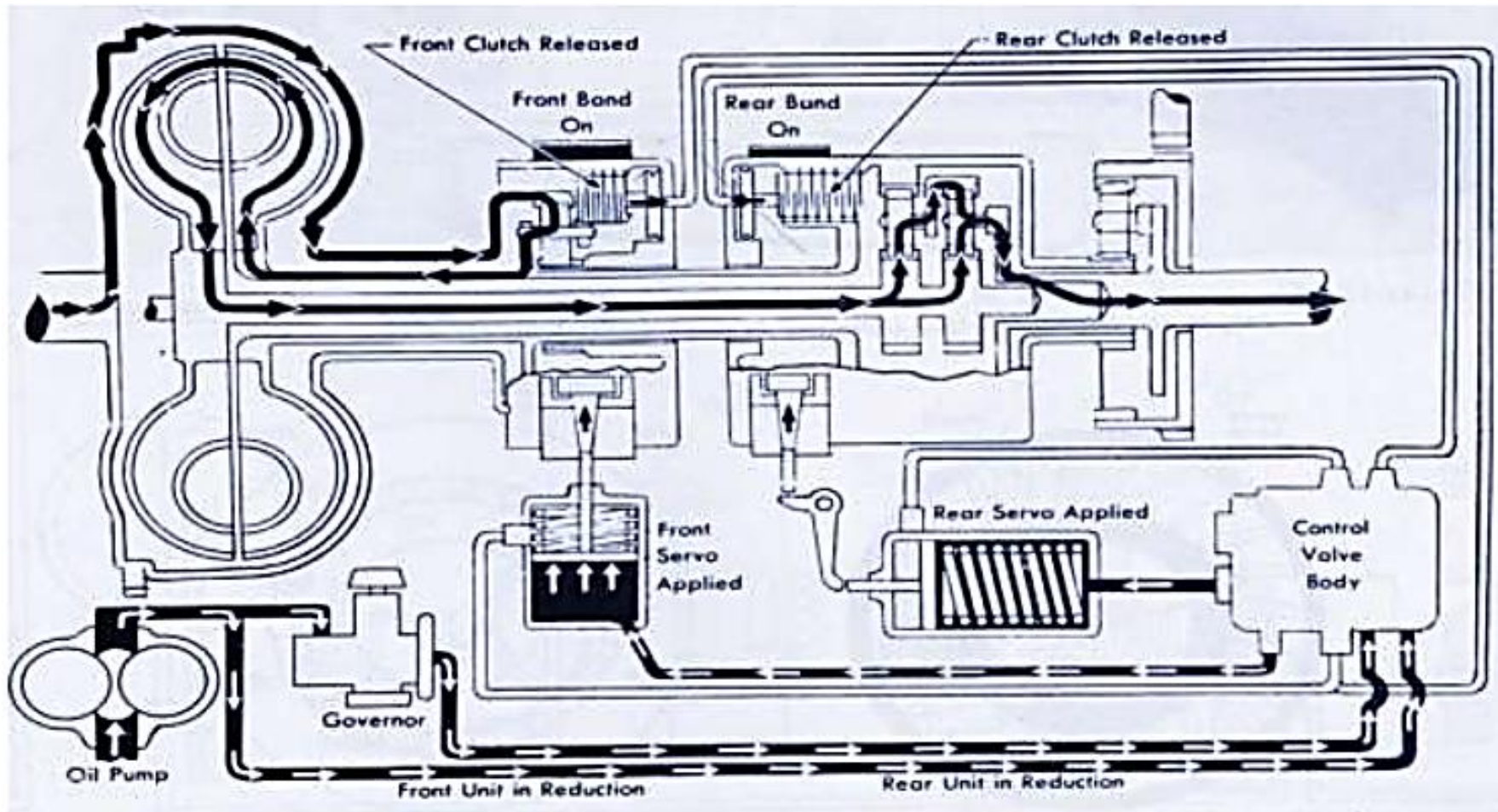



- The converter out circuit starts at the torque converter. Fluid flows out of the converter in between the outside of the turbine shaft and inside of stator support.
- The converter check valve is a valve in the converter in or out circuit, usually a ball check type valve that maintains minimum converter working pressure and prevents converter drain back through the rear lube circuit when the engine is shut off.
- Fluid then flows from the transmission through a cooler line to the oil cooler. Fluid flows from the cooler through the other cooler line and back to the transmission.
- The fluid then flows through the rear lube circuits and back to the sump of the transmission.



❖ Converter lock-up clutch:

- Several designs have been used to eliminate the inherent slippage of torque converters.
- The most popular and the predominate one in use currently, is the fiber disc friction style. A large metal or fiber disc is splined to the front of the turbine and turns with it.
- A piston is installed between the fiber disc and the inside of the front converter housing and is hydraulically sealed by O-rings. Between the fiber disc and the turbine a metal pressure plate or backing plate is installed.
- This plate is permanently fixed to the converter housing and therefore turns with it. When conditions are correct pressurized fluid is directed from the transmission hydraulic circuits through the hollow center of the input shaft to a cavity behind the piston.



- This causes the piston to move back towards the fiber disc and sandwiches it between the piston and the backing plate.
- Because the fiber disc is splined to the turbine this action locks the turbine to the converter housing and causes it to turn at the same speed thereby eliminating the slippage and increasing efficiency to 100%.
- At this point in the torque converter all three elements and the fluid turn basically as one unit.



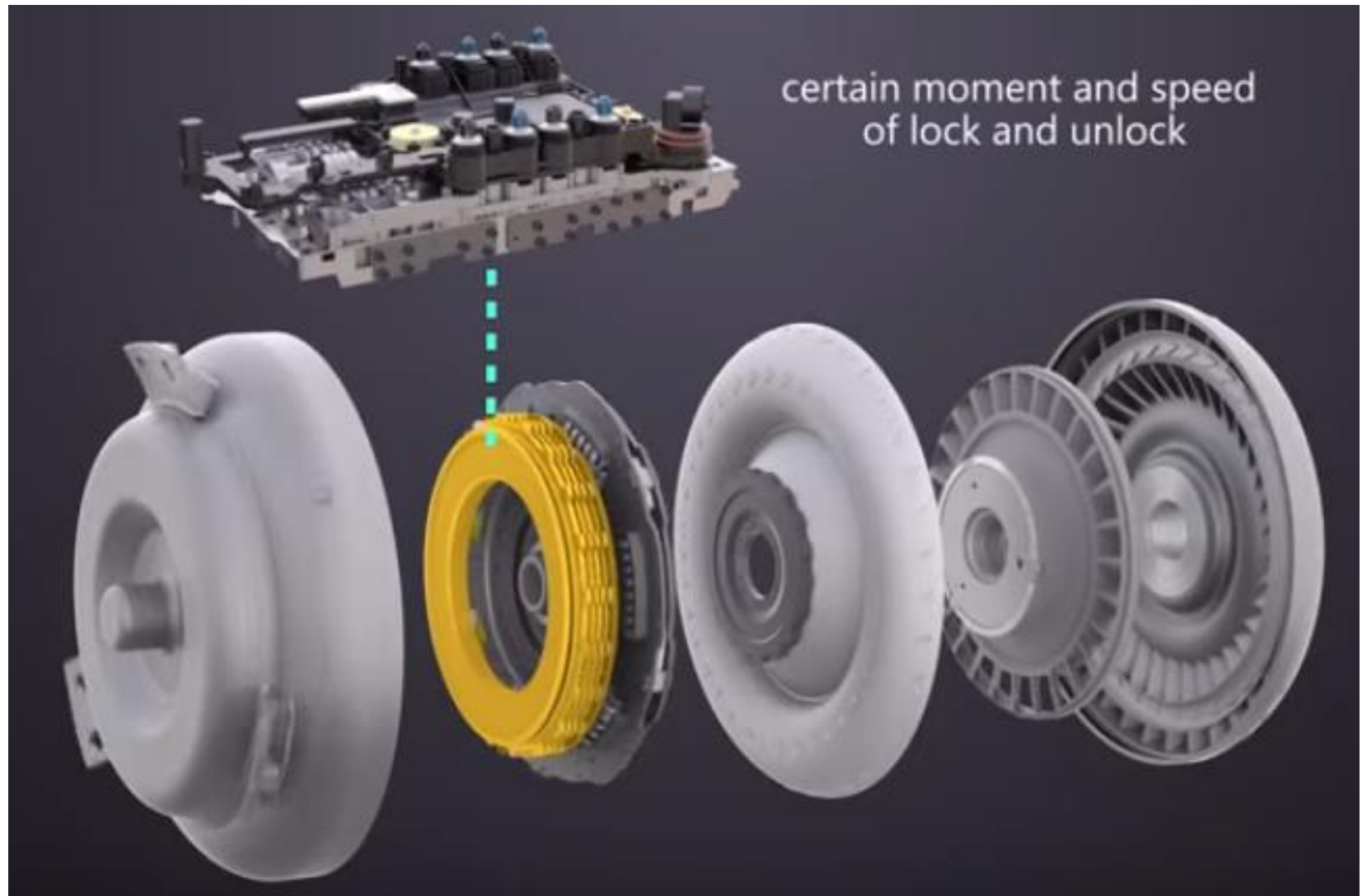



❖ Efficiency and torque multiplication

- A torque converter cannot achieve 100 percent coupling efficiency. The classic three element torque converter has an efficiency curve that resembles \cap : zero efficiency at stall, generally increasing efficiency during the acceleration phase and low efficiency in the coupling phase.
- The loss of efficiency as the converter enters the coupling phase is a result of the turbulence and fluid flow interference generated by the stator, and as previously mentioned, is commonly overcome by mounting the stator on a one-way clutch.
- Even with the benefit of the one-way stator clutch, a converter cannot achieve the same level of efficiency in the coupling phase as an equivalently sized fluid coupling. Some loss is due to the presence of the stator (even though rotating as part of the assembly), as it always generates some power-absorbing turbulence.
- Most of the loss, however, is caused by the curved and angled turbine blades, which do not absorb kinetic energy from the fluid mass as well as radially straight blades.



- Since the turbine blade geometry is a crucial factor in the converter's ability to multiply torque, trade-offs between torque multiplication and coupling efficiency are inevitable.
- In automotive applications, where steady improvements in fuel economy have been mandated by market forces and government edict, the nearly universal use of a lock-up clutch has helped to eliminate the converter from the efficiency equation during cruising operation.

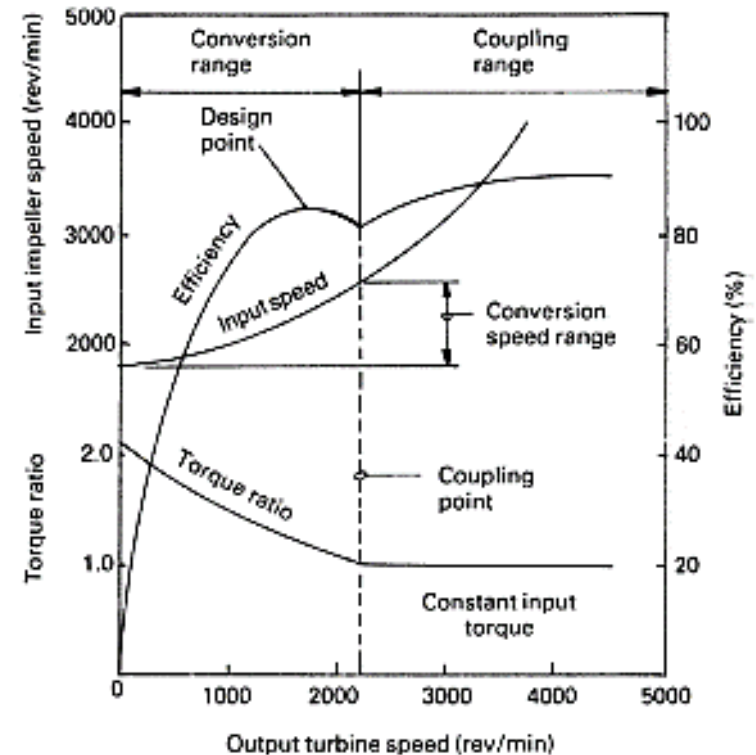

Fig. 4.11 Characteristic performance curves for a three element converted coupling



- The maximum amount of torque multiplication produced by a converter is highly dependent on the size and geometry of the turbine and stator blades, and is generated only when the converter is at or near the stall phase of operation.
- Typical stall torque multiplication ratios range from 1.8:1 to 2.5:1 for most automotive applications (although multi-element designs as used in the Buick Dynaflo and Chevrolet Turboglide could produce more).
- Specialized converters designed for industrial, rail, or heavy marine power transmission systems are capable of as much as 5.0:1 multiplication.
- Generally speaking, there is a trade-off between maximum torque multiplication and efficiency—high stall ratio converters tend to be relatively inefficient below the coupling speed, whereas low stall ratio converters tend to provide less possible torque multiplication.
- Torque converter increases the input torque by means of fluid coupling and supplies that torque to wheels.



❑ Capacity and failure modes:

❖ Overheating:

- Continuous high levels of slippage may overwhelm the converter's ability to dissipate heat, resulting in damage to the elastomer seals that retain fluid inside the converter.
- This will cause the unit to leak and eventually stop functioning due to lack of fluid.

❖ Stator clutch seizure:

- The inner and outer elements of the one-way stator clutch become permanently locked together, thus preventing the stator from rotating during the coupling phase. Most often, seizure is precipitated by severe loading and subsequent distortion of the clutch components.



- Eventually, galling of the mating parts occurs, which triggers seizure. A converter with a seized stator clutch will exhibit very poor efficiency during the coupling phase, and in a motor vehicle, fuel consumption will drastically increase.
- Converter overheating under such conditions will usually occur if continued operation is attempted.
- ❖ **Stator clutch breakage:**
 - A very abrupt application of power can cause shock loading of the stator clutch, resulting in breakage.
 - If this occurs, the stator will freely counter-rotate in the direction opposite to that of the pump and almost no power transmission will take place.
 - In an automobile, the effect is similar to a severe case of transmission slippage and the vehicle is all but incapable of moving under its own power.



❖ **Blade deformation and fragmentation:**

- If subjected to abrupt loading or excessive heating of the converter, pump and/or turbine blades may be deformed, separated from their hubs and/or annular rings, or may break up into fragments.
- At the least, such a failure will result in a significant loss of efficiency, producing symptoms similar (although less pronounced) to those accompanying stator clutch failure. In extreme cases, catastrophic destruction of the converter will occur.



❖ **Ballooning:**

- Prolonged operation under excessive loading, very abrupt application of load, or operating a torque converter at very high RPM may cause the shape of the converter's housing to be physically distorted due to internal pressure and/or the stress imposed by inertia (centrifugal force).
- Under extreme conditions, ballooning will cause the converter housing to rupture, resulting in the violent dispersal of hot oil and metal fragments over a wide area.



❖ Usage

- Automatic transmissions on automobiles, such as cars, buses, and on/off highway trucks.
- Forwarders and other heavy duty vehicles.
- Marine propulsion systems.
- Industrial power transmission such as conveyor drives, almost all modern forklifts, winches, drilling rigs, construction equipment.



❖ Advantages of Torque Converter

- It allows your vehicle to complete stop without stalling the engine.
- It makes driving easier.
- Torque converter gives more torque to your car when you accelerate out of the stop.
- Torque converter removes the clutch and produces the maximum torque as compared with a vehicle equipped with a clutch.
- Modern torque converters increase the torque of the engine by two or three time



❖ **Epicyclic or Planetary Gear train**

- Epicyclic gear trains are generally used for automatic transmission, overdrives, and final drives.
- The most commonly used gear trains in automatic transmission system are three-speed Simpson gear train and two-speed Ravingeau gear train.
- The layout of a simple single-stage epicyclic gear train is shown in Fig. 25.24. Epicyclic gears are very widely used in automatic transmission because,
 1. They are always in constant-mesh.
 2. Engagement of these gears may be obtained smoothly and quietly by the application of brake bands, and
 3. Considerable variation in gear ratios both forward and reverse can be obtained through epicyclic gear trains.



❖ Simple Epicyclic Gear Train

- An epicyclic single-stage gear train consists of an internally toothed annular (ring) A (Fig. 25.24) with a band brake encircling it.
- In the centre of this gear is sun gear S, which forms part of the input shaft.

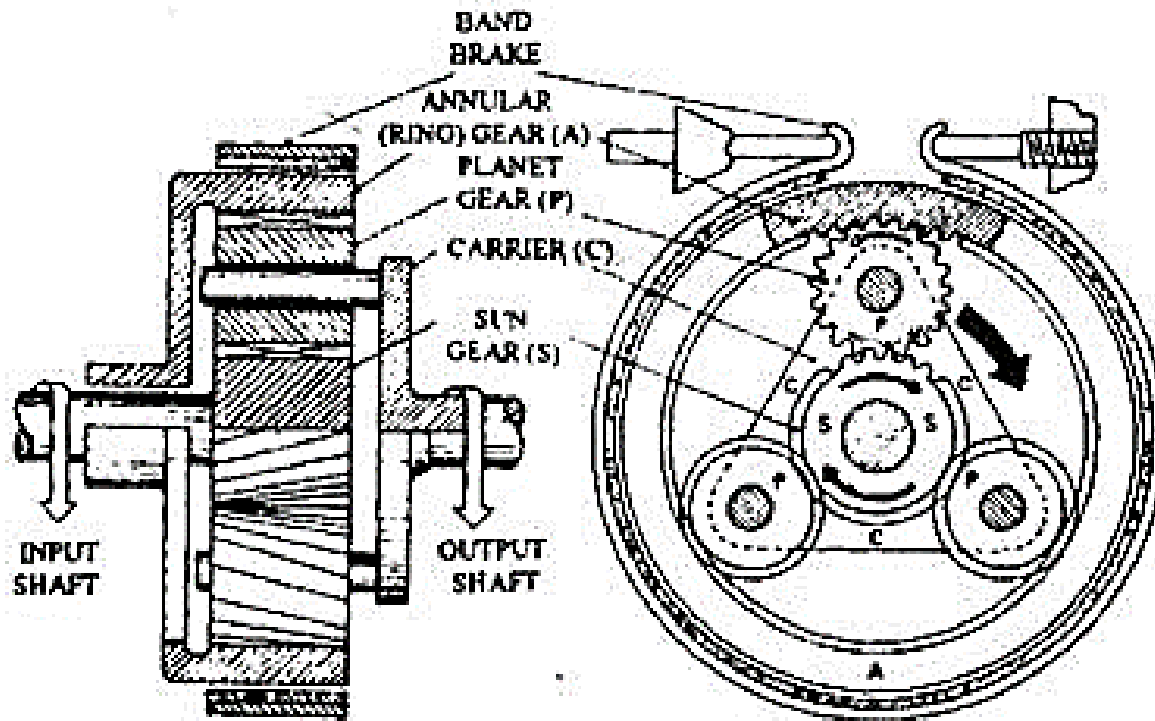

Fig. 25.24. Simple epicyclic gear train.



- The sun gear and the annular gear are connected by a number of planet (pinion) gears P which are mounted on a carrier C and is integral with the output shaft. For transmission of torque, either the sun gear, the carrier, or the annular gear must be held stationary.
- The situation is considered when only the annular gear is stationary. When the input sun gear shaft is driven keeping the annular gear band brake fixed, the planet gears simultaneously rotate around their axes and revolve around the input sun gear axis along the inner circumference of the annular gear. Consequently, the carrier and the output shaft, which support the planet-gear axes, also rotate, but slower than the input shaft.
- Let,
 T_a = number of teeth on annular, internal or ring gear,
 T_s = number of teeth on sun or center gear,
 T_p = number of teeth on planet gear
 T_c = number of effective teeth on arm or planet carrier,
Also, $T_a = T_s + 2T_p$ and $T_c = T_s + T_a$



❖ First Gear Ratio.

- The annular gear is held stationary and the planet carrier is driven by the power supplied to the sun gear.

$$\begin{aligned} \text{Gear ratio} &= \frac{\text{Speed of the driving shaft}}{\text{Speed of the driven shaft}} = \frac{\text{Teeth on the driven gear}}{\text{Teeth on the driving gear}} \\ &= \frac{\text{Teeth on planet carrier}}{\text{Teeth on sun gear}} = \frac{T_C}{T_S} = \frac{T_S + T_A}{T_S} = 1 + \frac{T_A}{T_S} \end{aligned}$$



❖ Second Gear Ratio.

- The sun gear is held stationary. The planet carrier is the driven member and the annular gear is the driving member.

$$\begin{aligned} \text{Gear ratio} &= \frac{\text{Teeth on the driven gear}}{\text{Teeth on the driving gear}} = \frac{\text{Teeth on planet carrier}}{\text{Teeth on annular gear}} \\ &= \frac{T_C}{T_A} = \frac{T_S + T_A}{T_A} = 1 + \frac{T_S}{T_A} \end{aligned}$$

❖ Reverse Gear

- Here the planet carrier is held stationary. The annular gear is driven by the sun gear to which the power is applied.

$$\text{Reverse gear ratio} = \frac{\text{Teeth on the driven gear}}{\text{Teeth on the driving gear}} = \frac{\text{Teeth on annular gear}}{\text{Teeth on sun gear}} = \frac{T_A}{T_S}$$



❖ Compound Epicyclic Gear Train

- A simple epicyclic gear train presented above can not provide adequate velocity ratios. Therefore a compound epicyclic gear train (Fig. 25.26) is used in a gearbox to give higher velocity ratios and to allow several ratios to be obtained.
- A compound epicyclic gear train is obtained by joining together all the arms of simple gear train ; of course the compounding can be made by different methods.
- In these trains the members, which become fixed when the trains are in use, are arranged to be free. The brakes are provided to bring any of these members to rest as and when required.
- The train to which that member belongs then come into operation and if that member is released the train becomes non-operational. Generally some of the wheels are common to all the epicyclic trains.



- For only small degrees of overdrive (undergearing), for example 0.82 : 1 (22%), the simple epicyclic gearing requires a relatively large diameter annulus ring gear, about 175 mm, to provide sufficiently large gear teeth for adequate strength.
- To reduce the diameter of the annulus ring gear for a similar degree of overdrive, a compound epicyclic gear train can be used which incorporates double pinion gears on each carrier pin. This reduces the annulus diameter to about 100 mm and the number of annulus teeth to 60 only as compared to the 96 annulus teeth in the simple epicyclic gear train.

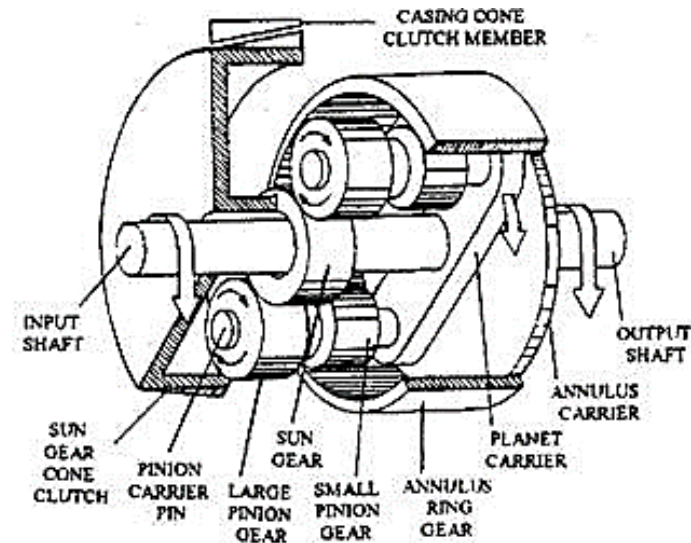
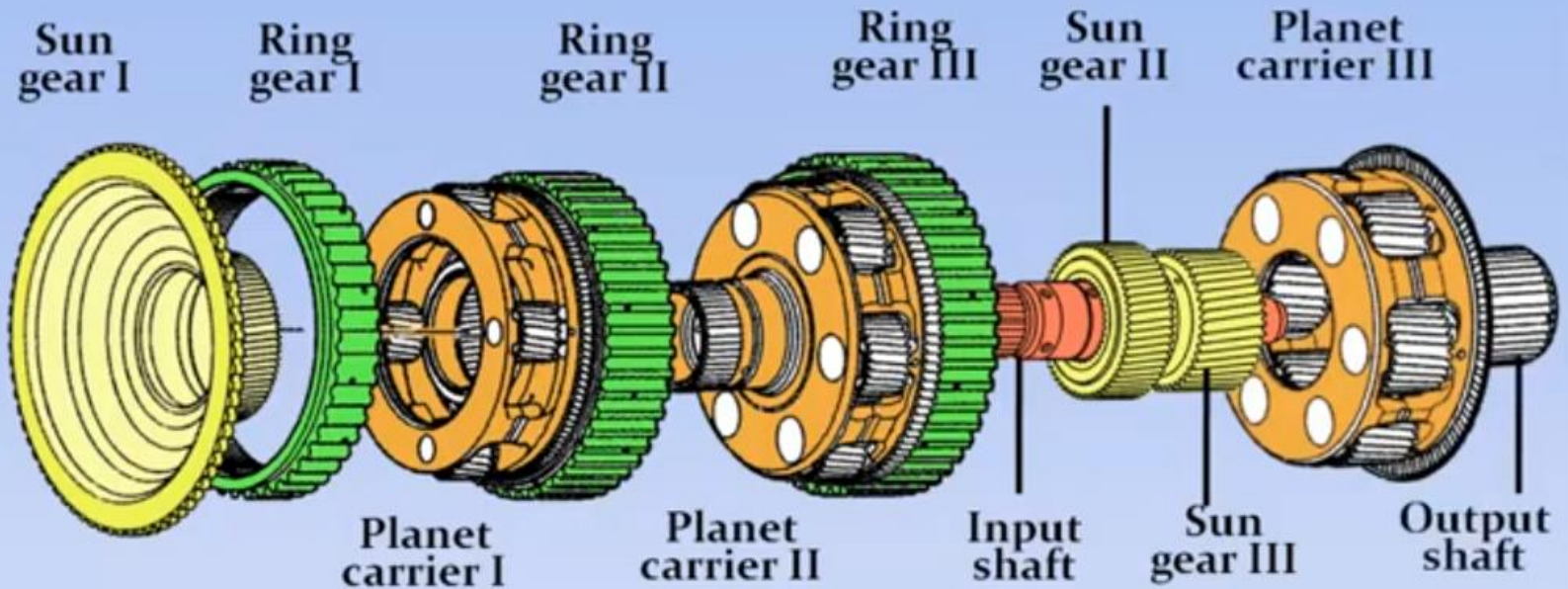

Fig. 25.26. Compound epicyclic gear train.



Compound Gear Sets

KANSOW



3 planetary gear sets [ZF-EcoLife]



❖ Wilson Gearbox History

- According to Arias Paz (1958), the use of epicyclic gears in gearboxes began in the early days of automobiles in models like the Oldsmobile and Lanchester and later on Ford used them in his famous model T.
- In 1929 the use of planetary gears in automotive transmissions starts in a model called Wilson Gearbox, created by Walter Gordon Wilson. Born in Blackrock in Ireland in 1874 and graduated in mechanical engineering, Walter Gordon Wilson got involved with the British military industry around 1904.
- During the First World War he incorporated planetary gears in the Mark V tank, allowing the tank to be operated by a single driver instead of the four previously required. After the war, in 1928 Wilson improved the transmission used in the Mark V tank, giving rise the pre-selector gearbox. In a partnership with JD Siddeley he created the company Improved Gears Ltd to develop the commercial project of the Wilson Gearbox, the company later became Self-Changing Gears Ltd. Afterwards in England the Wilson gearbox was applied in buses. However, due to its complex construction for the time it fell into disuse.



❖ Wilson Gearbox

- The gearbox comprises of three sub assemblies, the running gear, the brake harness and the control mechanism housed in an oil tight container.
- This consists of a four epicyclic trains of gear inter connected, so that different ratios and a reverse can be obtained. The direct drive is achieved by engaging the clutch.
- One train of epicyclic gearing is used for all the various ratios, its sun S1 being secured to a shaft D coupled permanently to the engine and its arm A1 to the shaft E which is coupled permanently to the driving road wheels and the various ratios are obtained by driving the annulus/Ring R1 at different speeds in relations to the engine speed.
- R- Ring Gear
- A- Arm/carrier
- S- Sun Gear
- B- Brake

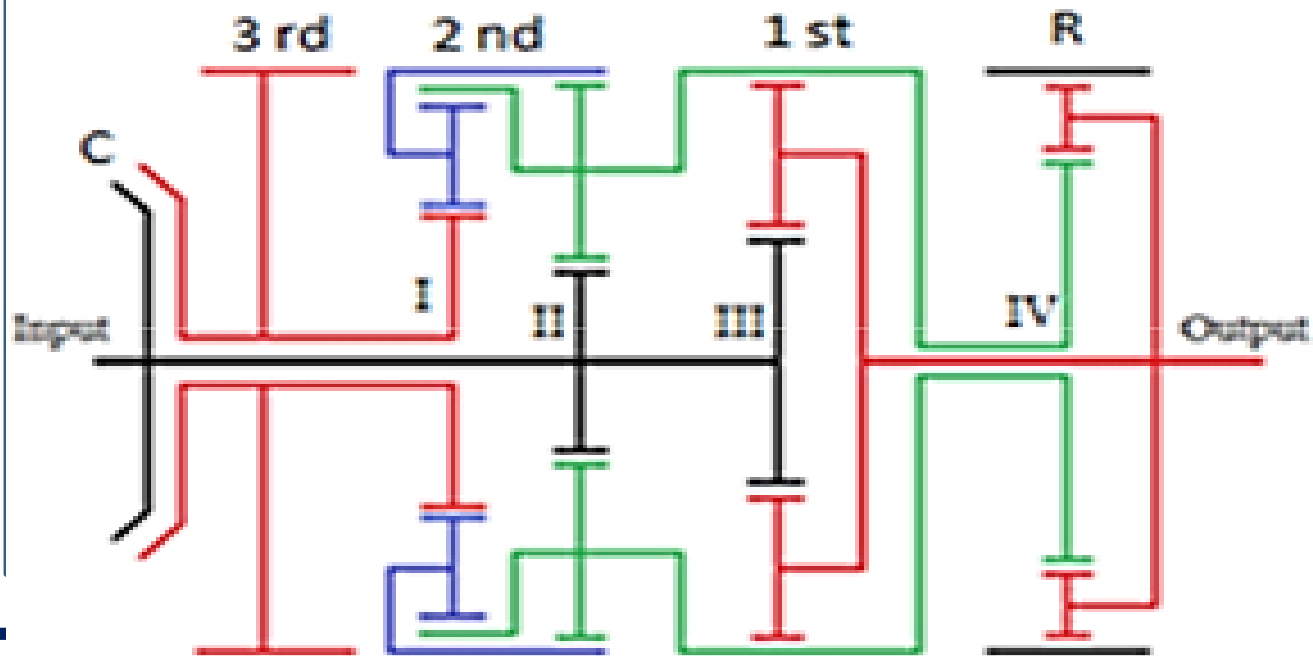
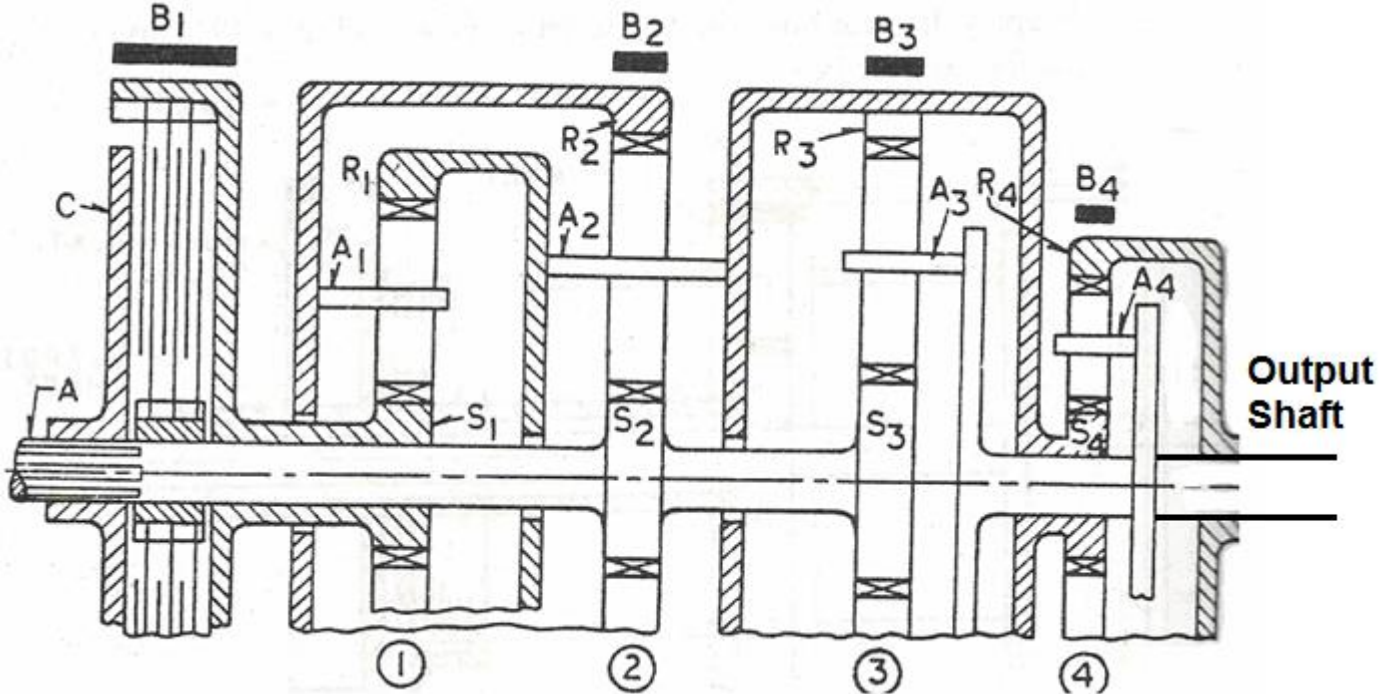

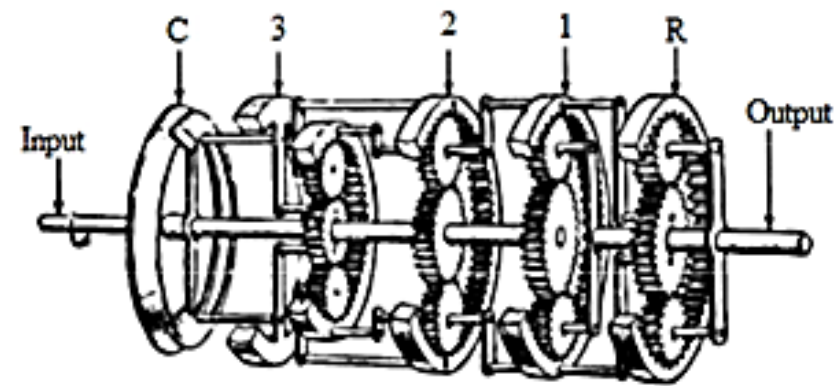
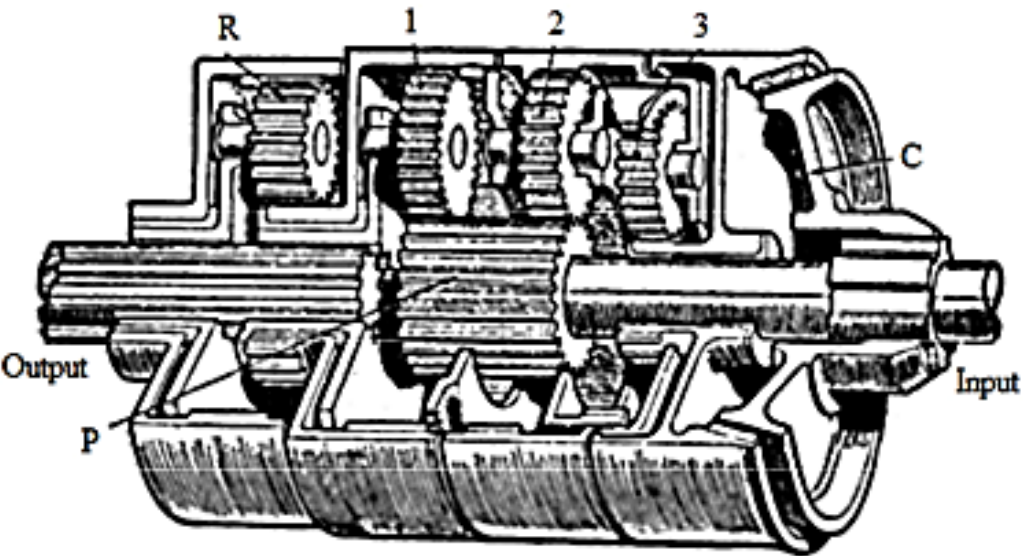
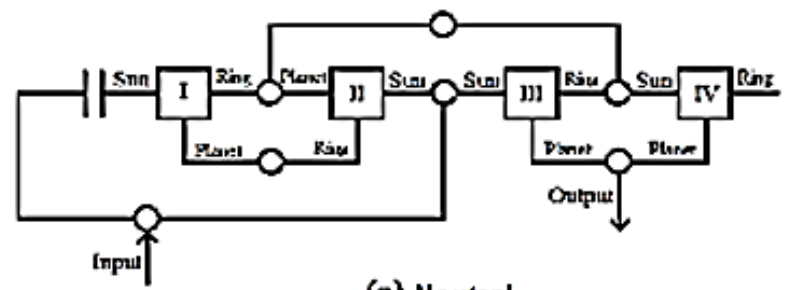
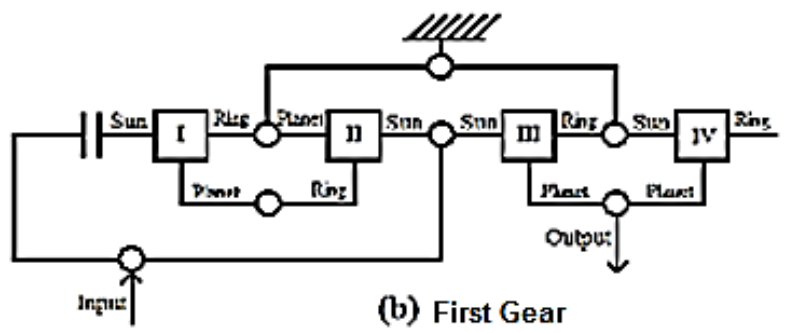

Figure 1. Wilson gearbox (Adapted from Arias Paz, 1958).



(a) Neutral



(b) First Gear

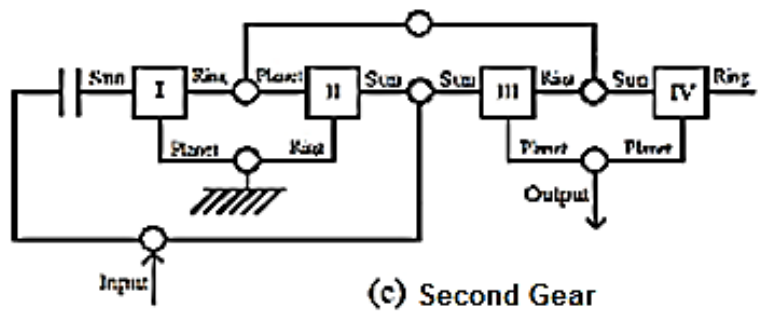

(c) Second Gear

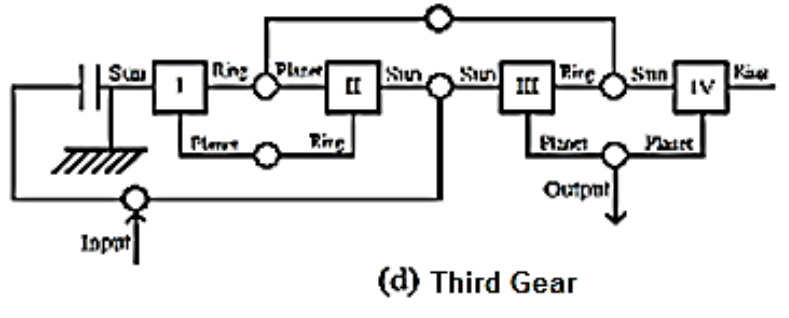

(d) Third Gear

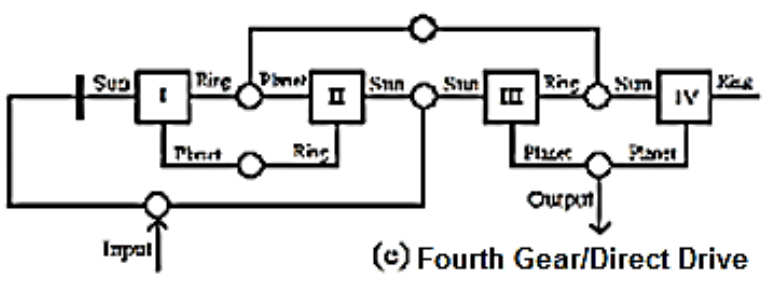

(e) Fourth Gear/Direct Drive

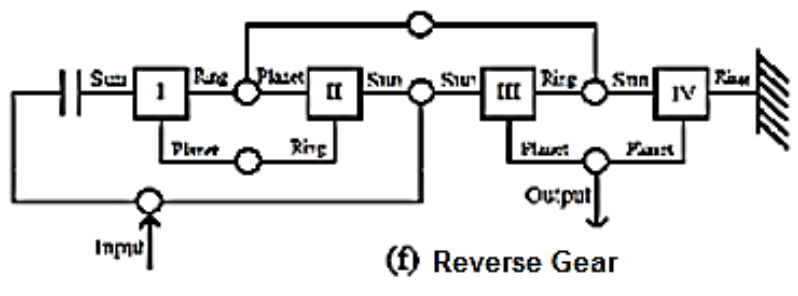

(f) Reverse Gear

Figure 3. Block diagram of a four speed Wilson Gearbox



- In Fig.3 the first case,
 - (a) represents the gearbox when the vehicle is disengaged (neutral),
 - (b) represents the first speed engaged, in other words with the ring gear of the planetary III braked
 - (c) the second speed engaged, in other words with the ring gear of the planetary II braked,
 - (d) the third speed engaged, in other words, the outlet portion of the clutch braked, which corresponds to stop the sun gear of the planetary I,
 - (e) direct drive, in other words, when the clutch is engaged and
 - (f) the reverse speed which is obtained by braking the ringgear of the planetary IV.

❖ Operation

❑ First Gear

- First gear is obtained by applying a brake to the first gear train ring gear R3 by applying B3. So that it is held stationary. The engine will then, be turning the sun gear S3.
- So that the planet gears will be rolling round inside the ring gear R3 carrying their arm A3 round with them. As this arm A3 fixed to the output shaft its motion is imparted to it.

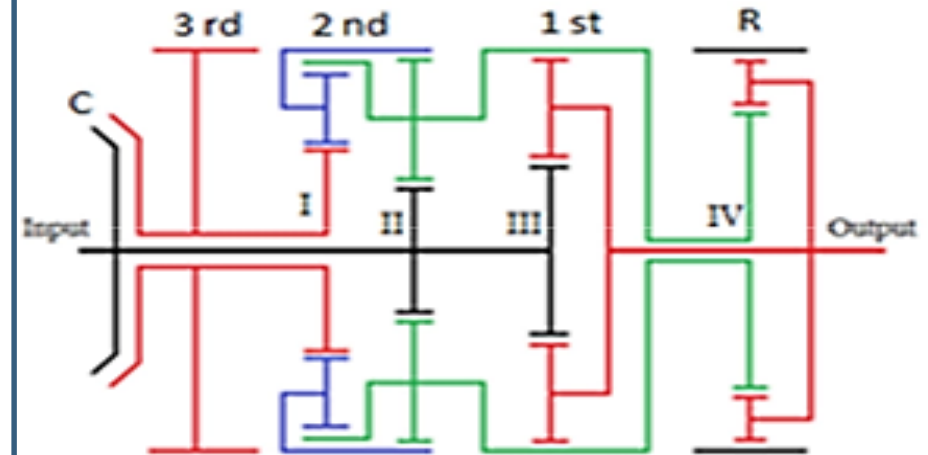
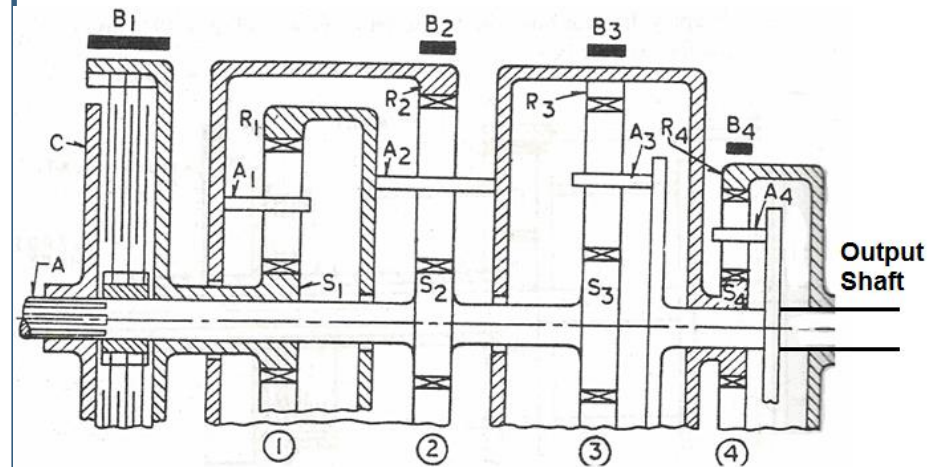

❑ Second Gear

- Second gear is obtained by holding the second gear train ring R2 stationary by its brake B2. The main sun gear S2 still turned by the engine cause the planet gear to revolve and their arm A2.
- But this arm A2 is connected to the first gear train ring gear R3 which therefore turns, speeding up the rotation of the planet gear and arm A3 and it turning the output shaft faster than was the case in first gear, i.e. less reduction.

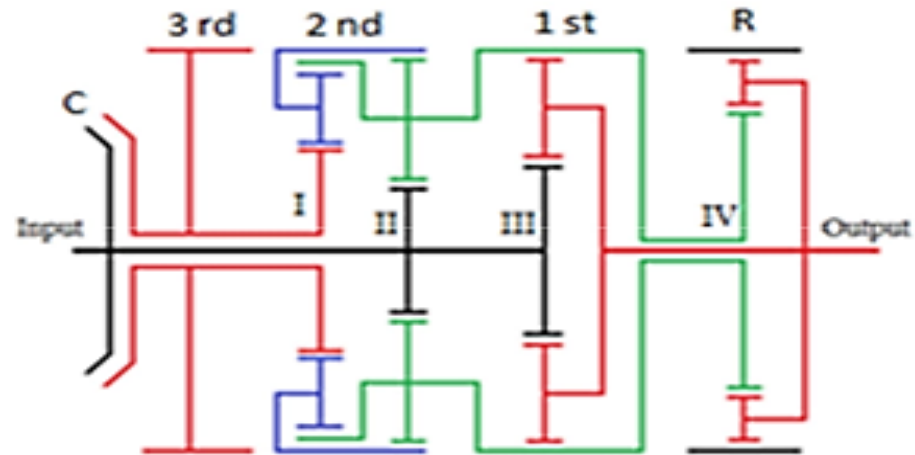
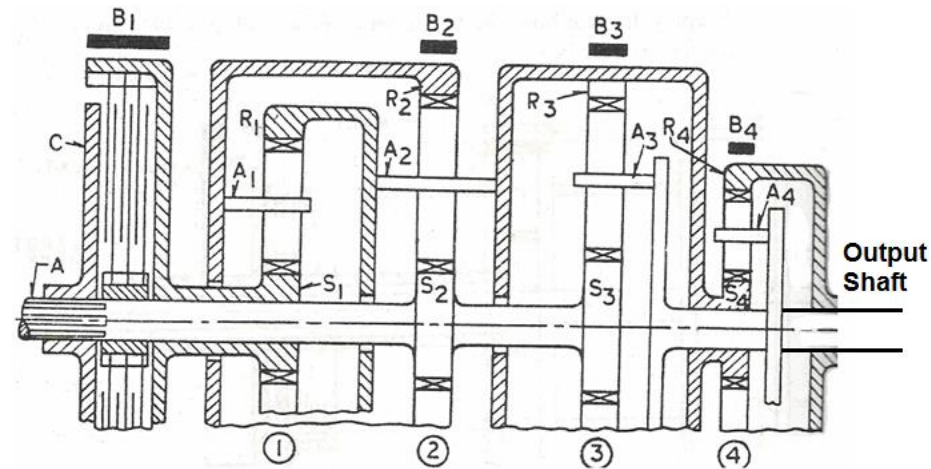



□ Third Gear

- Third gear is obtained by holding the third gear sun wheel S_1 by brake drum holding (B_1) which is interconnected further the ring gear R_1 is an integral part of the second gear planet arm A_2 which is turn connected to the first gear ring R_3 .
- The third gear arm A_3 is connected to the second gear annulus R_2 so driving it in same directed as the engine i.e increasing its speed so the drive is taken back through the second gear planets and arm A_2 and the first gear train ring R_3 both of which are speeded up.
- The result is to speed up the first gear train arm A_3 which are connected to output shaft. In other words by interconnecting the second and third arms, an increase of speed is obtained at the first gear train annulus which increases the speed of the arm A_3 .

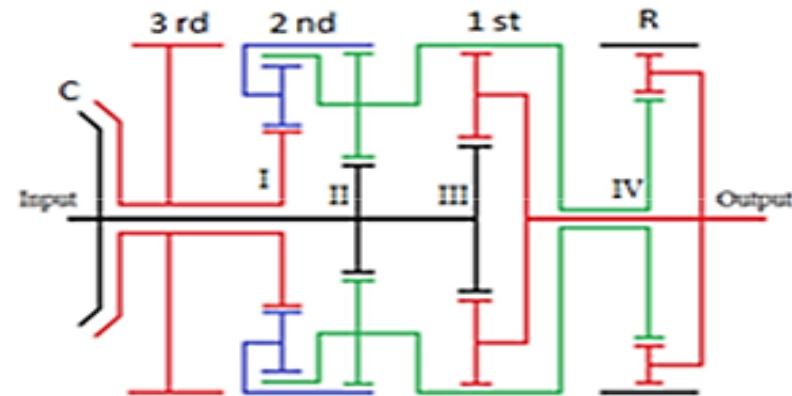
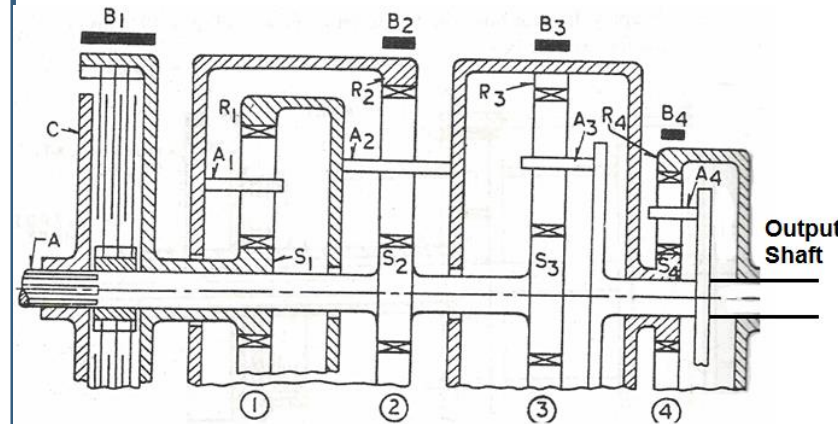



□ Top Gear

- In the top gear all the gear trains revolves freely as solid block driving the output shaft at engine speed.
- In this, the clutch is engaged which transmits the power to main shaft i.e input shaft which holds S2 and S3.
- Those are all the sun gear will be revolving at the same speed. Since the first and second gear train sun wheel are fixed to the shaft (output) and their will not be any individual action of the various gear train. All the brake bands being loose their annulus.

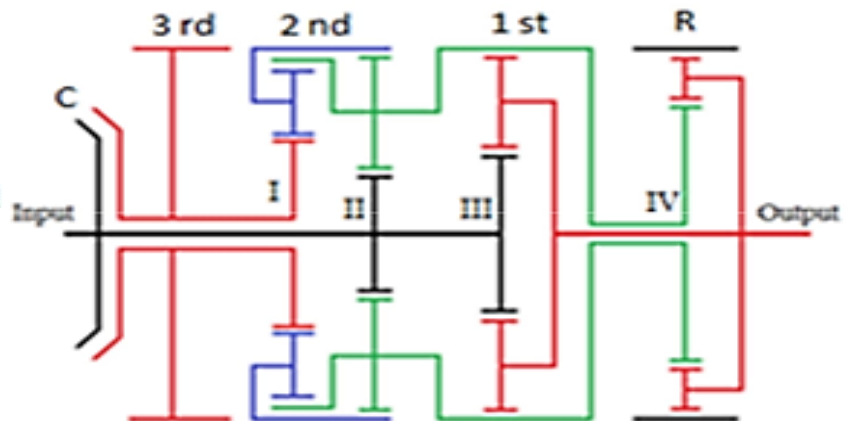
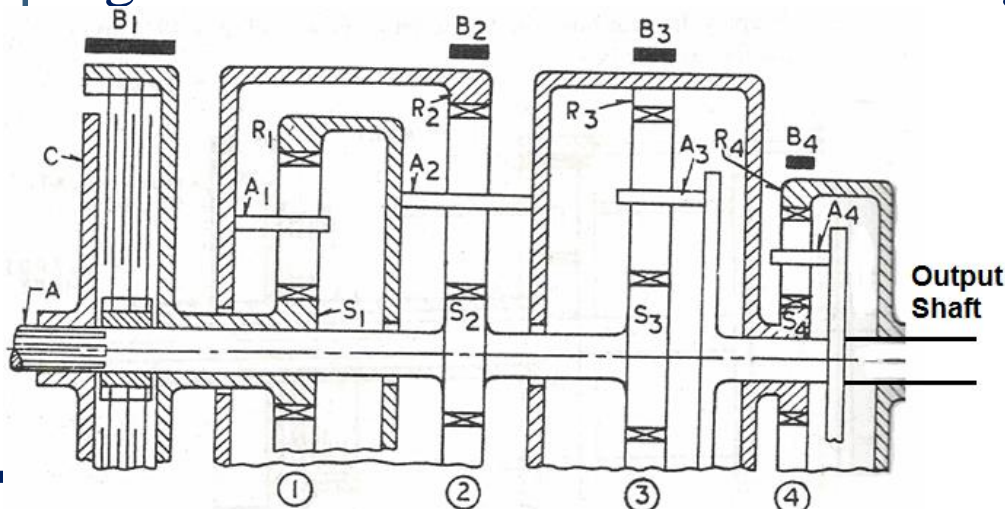



❑ Reverse Gear

- The first gear annulus R3 is connected to the sun gear S4 of the reverse gear train and hence drive output rotates opposite to the engine rotation.
- When the brake B4 is applied reverse gear ring/annulus R4 the reverse gear planet wheels turned by the reverse sun gear connected to first annulus and therefore turning opposite to the engine speed output shaft. As the arm A4 connected to the output shaft the direction of the rotation of the propeller shaft reversed.

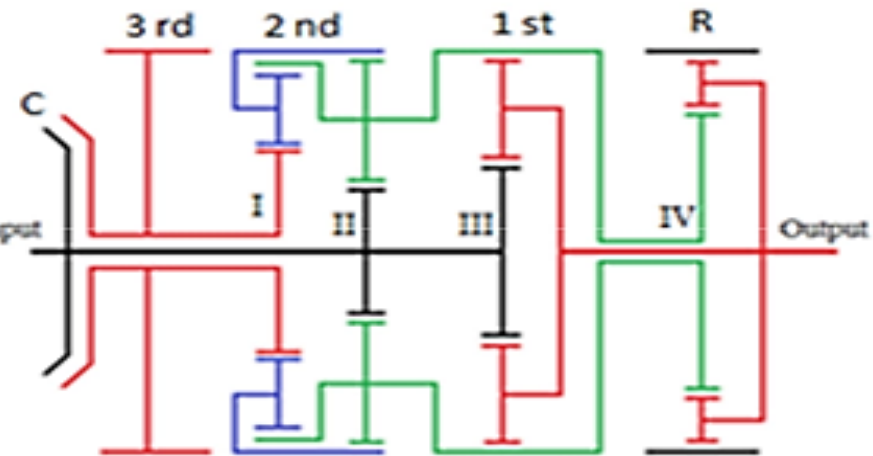
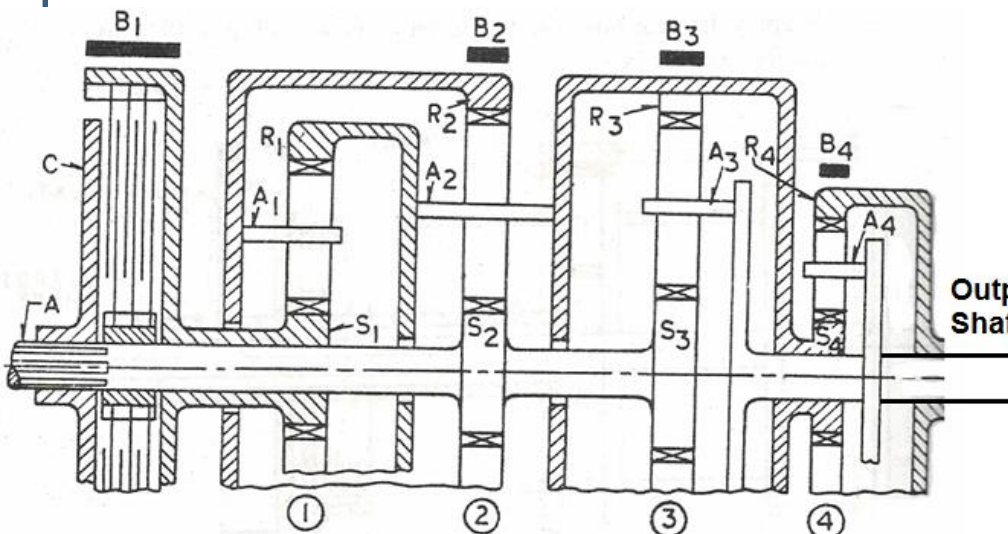



Example: An arrangement of the Wilson epicyclic gearbox giving four forward and one reverse speed of shaft D for an input speed of shaft E is shown in Fig. below. In 1st gear I_1 is fixed. In 2 gear I_2 is fixed. In 3 gear S_3 is fixed. Top gear F is locked to G_i . Reverse gear I_4 is connected to S_4 and h is fixed. The numbers of teeth on the gears are : $S_1 = 20$, $S_2 = 20$, $S_3 = 17$, $S_4 = 26$, $h = 70$, $h = 70$, $h = 61$ and $74 = 70$. Calculate all the gear ratios. If 22.1 kW is transmitted in 1st gear at an engine speed of 3000 rpm, find the required fixing torque on the annulus I.

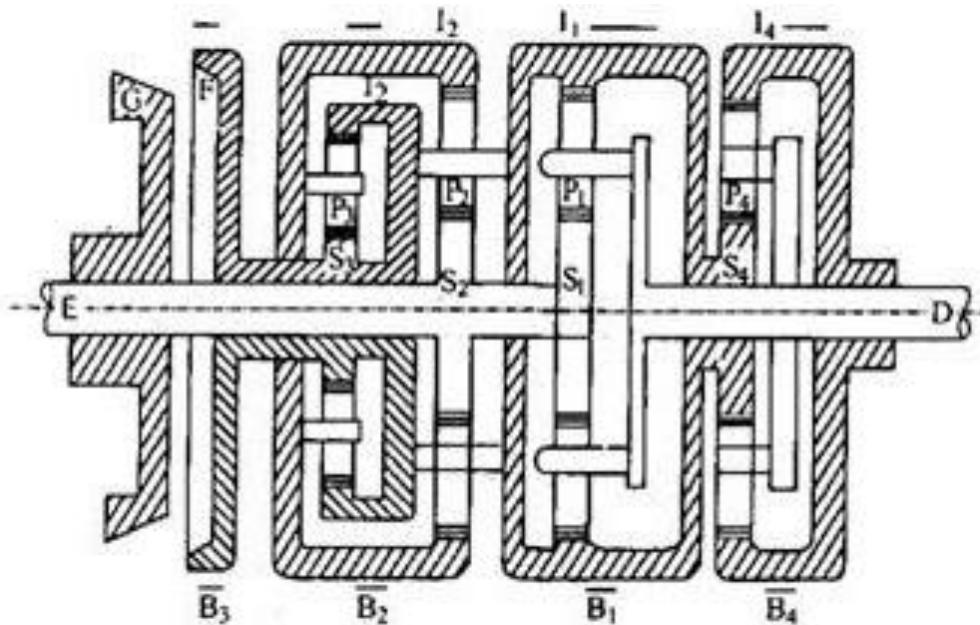



Solution:

The Wilson gear box giving four forward and a reverse ratio, contains four sun wheels S_1, S_2, S_3 and S_4 , four internal gears I_1, I_2, I_3 and I_4 . Each sun is geared to the corresponding annulus by means of three planet wheels and thus there are four sets of planet wheels, P_1, P_2, P_3 and P_4 . B_1, B_2, B_3 , and B_4 are four contracting brake bands to bring the brake drums to rest. Only one of the brake bands is contacted for each gear ratio, all others remaining free. The action of the gearbox is as follows :

First Gear. The annulus I_1 is brought to rest by means of the brake band B_1 . Thus the motion is transmitted from E and D through the simple epicyclic train S_1, P_1 and I_1 .

The equation applicable is
$$\frac{N_{I_1} - N_C}{N_{S_1} - N_C} = -\frac{T_{S_1}}{T_{S_2}} = -\frac{20}{70} = -\frac{2}{7}$$

or
$$\frac{0 + N_C}{N_{S_1} - N_C} = \frac{2}{7} \quad (\because N_{S_1} = 0)$$

or
$$9N_C = 2N_{S_1}$$

or
$$\frac{N_{S_1}}{N_C} = 4.5$$

Thus
$$\frac{N_E}{N_D} = \frac{\text{Speed of driving shaft}}{\text{Speed of drive shaft}} = \frac{N_{S_1}}{N_C} = 4.5 \text{ Ans.}$$



Second Gear. The brake band B_2 is contracted to bring annulus I_2 to rest. The motion is then transmitted from E to D through the compound epicyclic train S_2, P_2, I_2 and S_1, P_1, I_1 . There are two equations connecting them.

Considering first equation,
$$\frac{N_{I_2} - N_{I_1}}{N_{S_2} - N_{I_1}} = -\frac{T_{S_2}}{T_{I_2}}$$

or
$$\frac{0 - N_{I_1}}{N_{I_1} - N_{S_2}} = -\frac{20}{70} = -\frac{2}{7}$$

gives
$$N_{I_1} = \frac{2}{9} N_{S_2} = \frac{2}{9} N_{S_1}$$

The second equation is
$$\frac{N_{I_1} - N_C}{N_{S_1} - N_C} = -\frac{T_{S_1}}{T_{I_1}}$$

or
$$\frac{\frac{2}{9} N_{S_1} - N_C}{N_{S_1} - N_C} = -\frac{20}{70} = -\frac{2}{7}$$

or
$$\frac{32}{9} N_{S_1} = 9N_C$$

Hence,
$$\frac{N_E}{N_D} = \frac{N_{S_1}}{N_C} = \frac{81}{32} = 2.53. \text{ Ans.}$$

Third Gear. The sun S_2 is brought to rest by means of brake band B_2 . The motion is then transmitted from E to D through three epicyclic trains S_3, P_3, I_3 ; S_2, P_2, I_2 and S_1, P_1, I_1 . There shall be three equations describing the motion.

First equation gives,
$$\frac{N_{I3} - N_{I2}}{N_{S3} - N_{I2}} = -\frac{T_{S3}}{T_{I2}} = -\frac{17}{61}$$

or
$$\frac{N_{I3} - N_{I2}}{0 - N_{I2}} = -\frac{17}{61}$$

or
$$61N_{I3} = 78N_{I2}$$

Hence
$$N_{I2} = \frac{61}{78}N_{I3} = \frac{61}{78}N_{I1}$$

Second equation gives,
$$\frac{N_{I2} - N_{I1}}{N_{S2} - N_{I1}} = -\frac{T_{S2}}{T_{I2}}$$

or
$$\frac{\frac{61}{78}N_{I1} - N_{I1}}{N_{S1} - N_{I1}} = -\frac{20}{70} = -\frac{2}{7}$$

Hence,
$$N_{I1} = \frac{156}{275}N_{S2} = \frac{156}{275}N_{S1}$$

Third equation is
$$\frac{N_{I1} - N_C}{N_{S1} - N_C} = -\frac{T_{S1}}{T_{I1}}$$

or
$$\frac{\frac{156}{275}N_{S1} - N_C}{N_{S1} - N_C} = -\frac{20}{70} = -\frac{2}{7}$$

or

$$\frac{1642}{275} N_{S1} = 9N_C$$

Hence,

$$\frac{N_E}{N_D} = \frac{N_{S1}}{N_C} = \frac{9 \times 275}{1642} = 1.507 = 1.51. \text{ Ans.}$$

Top Gear. In this case the cone clutch G_1 is used to prevent all relative motions between the sun S_3 and the engine shaft E. Thus the epicyclic gears are locked together and shaft D runs at the same speed as the shaft E.

Hence

$$\frac{N_E}{N_D} = 1. \text{ Ans.}$$

Reverse Gears. The annulus I_4 is brought to rest by means of brake band B_4 . The motion is transmitted from E to D through S_1, P_1, I_1 and S_4, P_4, I_4 . The two equations are as follows :

First equation is

$$\frac{N_{I4} - N_C}{N_{S4} - N_C} = -\frac{T_{S4}}{T_{I4}} = -\frac{26}{70} = -\frac{13}{35}$$

or

$$\frac{0 - N_C}{N_{S4} - N_C} = -\frac{13}{35}$$

or

$$13 N_{S4} = 48 N_C$$

or

$$N_{S4} = \frac{48}{13} N_C = N_{I1}$$



Second equation is

$$\frac{N_{I1} - N_C}{N_{S1} - N_C} = -\frac{T_{S1}}{T_{I1}} = -\frac{20}{70} = -\frac{2}{7}$$

or

$$\frac{\frac{48}{13}N_C - N_C}{N_{S1} - N_C} = -\frac{2}{7}$$

or

$$\frac{219}{13}N_A = -2N_{S1}$$

Hence,

$$\frac{N_E}{N_D} = \frac{N_{S1}}{N_A} = -\frac{219}{13 \times 2} = -8.42. \text{ Ans.}$$

The engine torque

$$= \frac{60000 P_w}{2\pi N} = \frac{60000 \times 22.1}{2\pi \times 3000} = 70.38 \text{ Nm.}$$



- The above input torque acts in the same direction as the engine speed.
- The output torque = $4.5 \times 70.38 = 316.72$ Nm where 4.5 is the first gear ratio. This torque acts on whatever the gear is driving in the direction of the output speed N_d .
- Therefore, the reaction of this torque that acts on the gearbox is in the opposite direction to the above output torque.
- The fixing torque = $316.72 - 70.38 = 246.34$ N. The fixing torque is required to keep the gearbox in equilibrium and acts in this case in the same direction as input torque.



❖ **Semi Automatic Transmission (SAT) / Automated Manual Transmission (AMT):**

- A **semi-automatic transmission** (also known as an **automated manual**, **clutchless manual**, **auto-manual**, **semi-manual**, **trigger shift**, **flappy-paddle** or **paddle-shift** gearbox) is an automobile transmission that combines manual transmission and automatic transmission.
- Semi-automatic term refers to a **single-clutch manual transmission** (with an automated clutch, but requires the driver to shift the gears manually), allowing for convenient driver control of gear selection (in road cars), or a single-clutch sequential transmission with electronic operated paddle shifters and an electrohydraulic or electro-pneumatic actuated clutch and dog box gear engagement as used in race cars.



- Modern "Semi-automatic transmissions," also known as "automated manual transmissions" (AMTs) usually have a fully automatic mode, where the driver does not need to change gears at all, operating in the same manner as a conventional type of automatic transmission by allowing the transmission's computer to automatically change gear if, for example, the driver were redlining the engine.
- The AMT can be engaged in manual mode wherein one can up-shift or down-shift using the console-mounted shifter selector or the paddle shifters just behind the steering wheel, without the need of a clutch pedal.



- The AMT uses electronic sensors, pneumatics, processors and actuators to execute gear shifts on input from the driver or by a computer.
- This removes the need for clutch pedal which the driver otherwise needs to depress before making a gear change, since the clutch itself is actuated by electronic equipment which can synchronize the timing and torque required to make quick, smooth gearshifts.
- AMT has a clutch but there is no clutch pedal. The clutch is operated by hydraulic/pneumatics or electric actuator based on signals from ECU.
- AMT operates on the manual transmission of car in the way a driver would: it engages and disengages the clutch and gears.

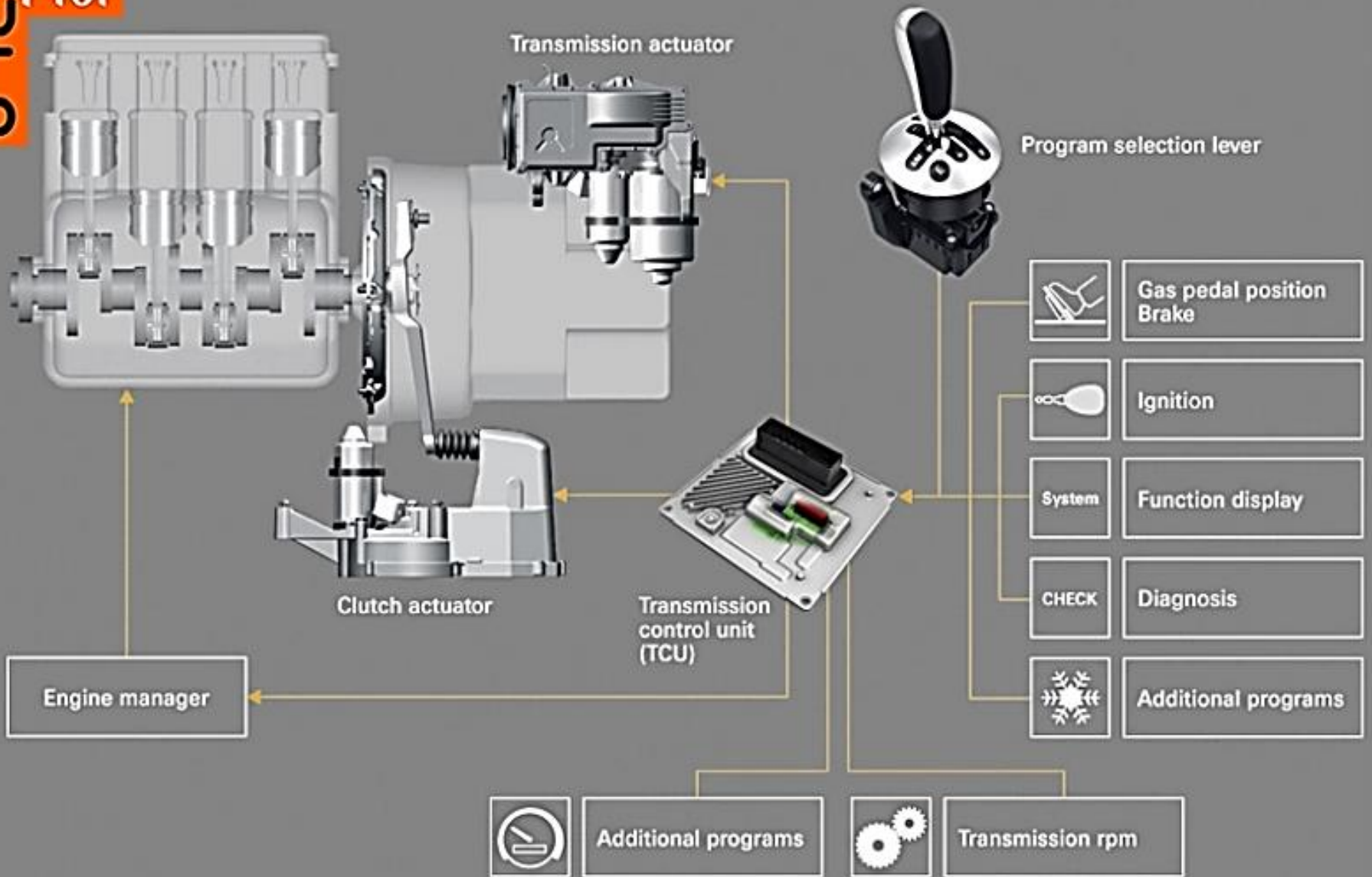

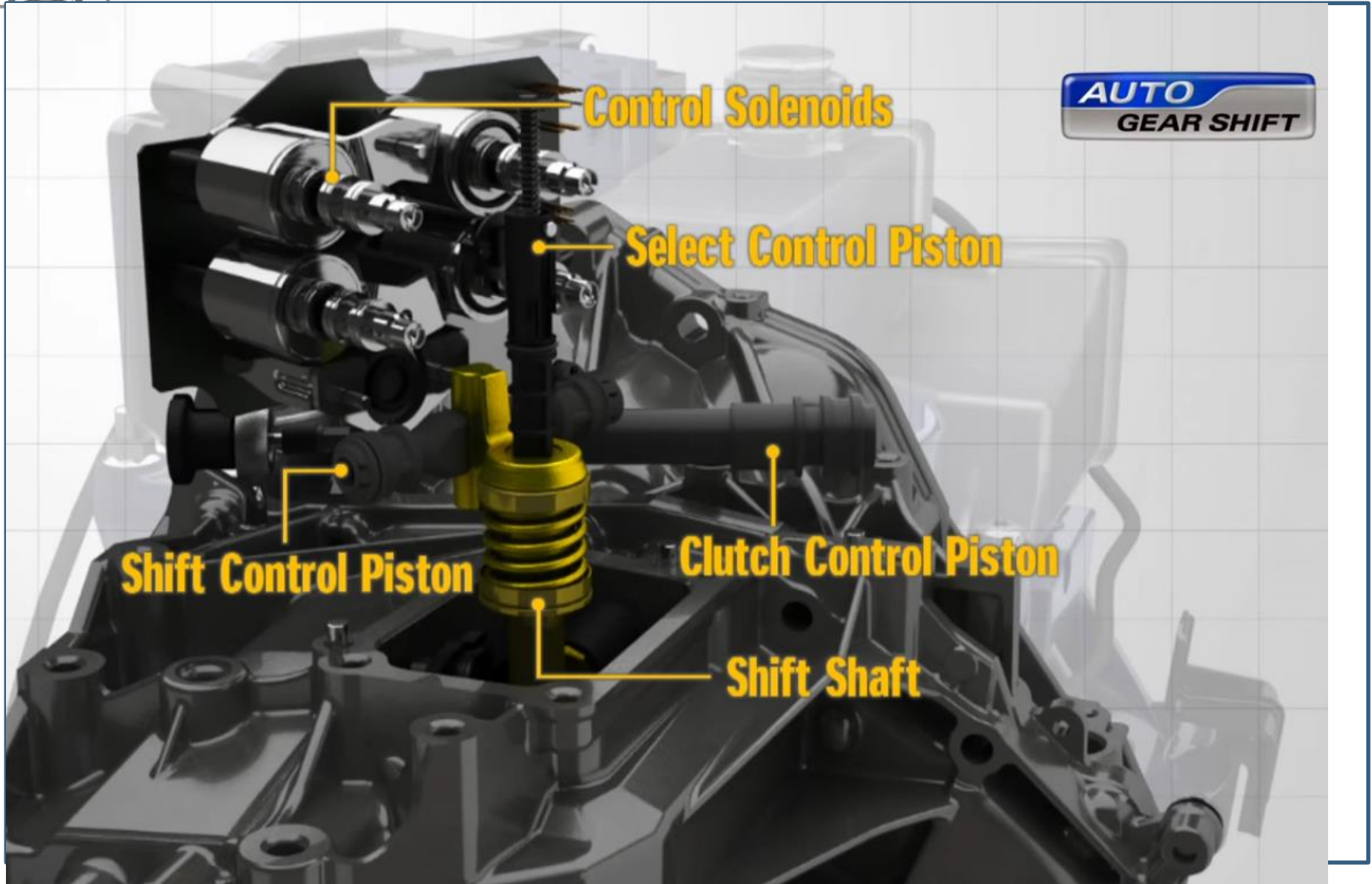

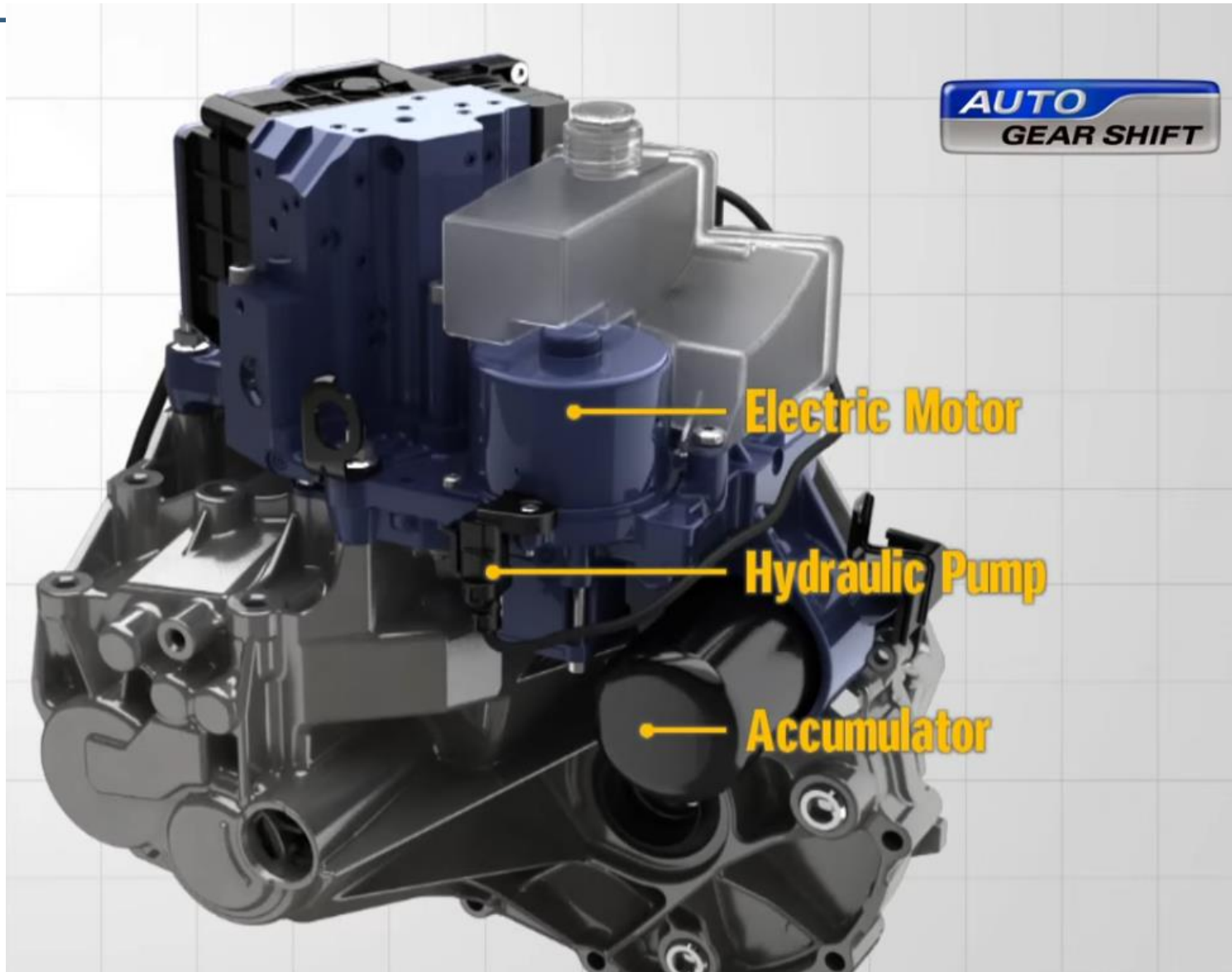



The typical lever layout from left to right:
Manual, Semi Automatic, Automatic

Semi automatics use actuators to control clutch engagement and gear shifting so the driver doesn't have to.



❑ CLUTCH ACTUATOR

- AMT is also known as '*Clutch-less Manual Transmission*' although the gearbox itself contains clutch.
- The name "*Clutch-Less*" because there is no clutch pedal to be pressed by driver. The clutch engagement and disengagement is done by actuators only.
- The electronically controlled clutch actuator uses an electric motor to operate the clutch.
- In the clutch actuator, the rotary movement of the electric motor is transferred via a set of gears to a linear movement that is needed to engage and disengage the clutch via the pressure plate.
- The clutch is operated via a release lever and bearing which then helps to engage or disengage the gears in the transmission



❑ GEAR ACTUATOR

- In a conventional manual gearbox, a set of cables or a link usually operates the gearbox in a two-step process.
- If the gearbox is cable operated like for example in a Tata Nano, two cables do the process of selection and engagement of the gears.
- The selection cable is actuated when one moves the gearshift lever from left to right or vice versa.
- The engagement cable is actuated when one actually shifts into one of the gates to engage a gear.
- Similarly, a link operated gearbox, like the single-link shifter mechanism found in the old Maruti 800 works on a similar principle.
- In the case of the 800, the link rotates for the selection process and moves longitudinally to the centreline of the car to engage a gear.
- Simplifying the shifter process, an Automated Manual Transmission, or AMT essentially negates these mechanical linkages by replacing them with electro-mechanical individual devices that work off the engine management and transmission management control units.



❑ TCU (Transmission Control Unit)

- The brain and boss of the gear control system is the TCU (Transmission Control Unit).
- Taking into account the driver's requirements and the operating conditions of the vehicle, it manages the gear changes by controlling the clutch, the gears and the engine.
- It takes its input from a number of sensors- like TPS, RPM sensors, Traction sensors, etc – and calculates the optimum shift points for smooth and efficient ride of vehicle.



□ Examples:

- **Maruti Suzuki** Celerio AMT is the first car in the country to get an Automatic Manual Transmission.
- **Ford** also made use of the Easytronic transmission in some of their smaller vehicles, such as the Fiesta, and the Fusion.
- **Alpha Romeo/Fiat** made use of a similar system to Opel's Easytronic which went by the name of Selespeed, which often comes with paddle shifters.
- **Honda** – Honda's own version of semi-auto Hondamatic hit the market in the 1970s. It later developed many variations including MultiMatic, S-matic, iShift, and SportShift.



❖ Advantages

- Can be installed with manual transmission system. No need to change whole transmission system.
- More fuel efficient, cheaper and lighter than traditional automatic transmission system.
- Reliable compared to manual transmission system as there is no clutch pedal.
- Prevents stalling during traffic.
- Gears can be changed automatically or manually according to driver's choice, smooth gear change.
- Fun to Drive.



❖ **Hydramatic Transmission/ Automatic Transmission(AT):**

- **Hydramatic** is an **automatic transmission** developed by both General Motors' Cadillac and Oldsmobile divisions.
- The hydramatic transmissions are termed as the fully automatic transmissions. They have essentially three or four speed and reverse epicyclic gearboxes with brakes and clutches operated by oil pressure.
- These are controlled by the joint action of a governor, whose speed is proportional to that of the car. Valve actuated transmission are currently in use.
 - Hydramatic drive
 - Controlled-coupling hydramatic transmission
 - Three-speed hydramatic transmission



- The hydramatic drive does not have a clutch pedal to engage and disengage the transmission system from the engine. The motion of the vehicle is controlled entirely by accelerator and brake.
- The hydramatic drive combines a four-speed forward and reverses automatic geared transmission with a fluid flywheel.



The 6L50 transmission is a Hydra-Matic six-speed rear and all-wheel drive automatic transmission produced by GM.



- The main components that make up an automatic transmission include:
 - Planetary Gear Sets which are the mechanical systems that provide the various forward gear ratios as well as reverse.
 - The Hydraulic System which uses a special transmission fluid sent under pressure by an Oil Pump through the Valve Body to control the Clutches and the Bands in order to control the planetary gear sets.
 - Seals and Gaskets are used to keep the oil where it is supposed to be and prevent it from leaking out.
 - The Torque Converter which acts like a clutch to allow the vehicle to come to a stop in gear while the engine is still running.
 - The Governor and the Modulator or Throttle Cable that monitor speed and throttle position in order to determine when to shift. Nowadays it is done by computer.
- On newer vehicles, shift points are controlled by Computer which directs electrical solenoids to shift oil flow to the appropriate component at the right instant.



❖ Gear Transmission System

- The geared transmission consists of three sets of constant mesh helical planetary gears placed in series. Two planetary gear sets provide the four forward gear changes, and the third is used for reverse.
- The fluid flywheel acts on the cushion the impact of the automatic shift as well as to reduce the torque reactions of the engine. A centrifugal governor in the transmission selects the proper gear for each speed and throttle position.
- The change from one gear to another is accomplished through hydraulically operated pistons. In some cases assisted by springs, within control planetary unit. The speed at which the various shifts occur is governed by the throttle position as well as by the centrifugal governor.

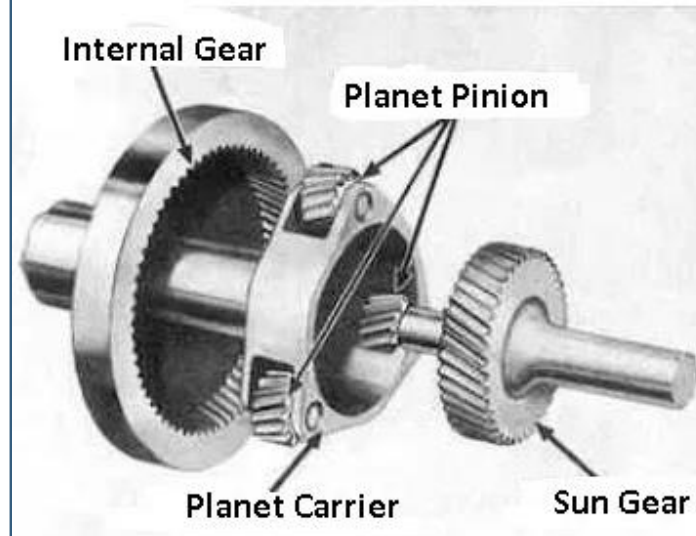



- When the throttle is opened, the gear shifts at higher and higher speed is obtained. Driver control is provided by a lever and segment mounted on the steering column beneath the steering wheel.
- This adjustment can be done to any one of the four positions- neutral, drive, low and reverse. In the drive, four forward transmission shifts automatically for any one of the four forward speeds. The low position is for hill climbing or muddy road.

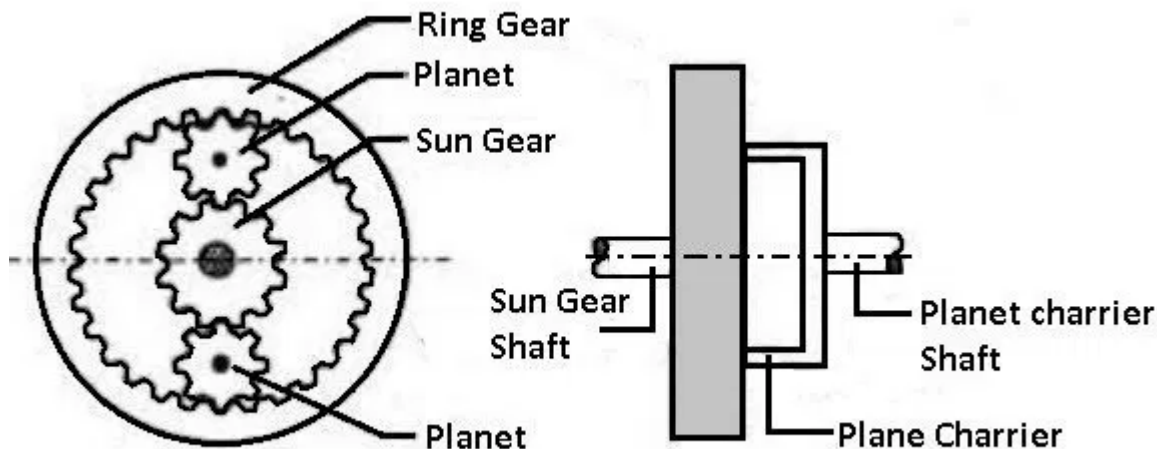

❖ Hydramatic Gear System

- The hydramatic gear system is shown in fig. It consists of three sets of planetary gears to obtain-four forward speeds and the reverse speed. In the front unit, the internal gear is driven by shaft linkage to a torus cover that is bolted to the engine flywheel.

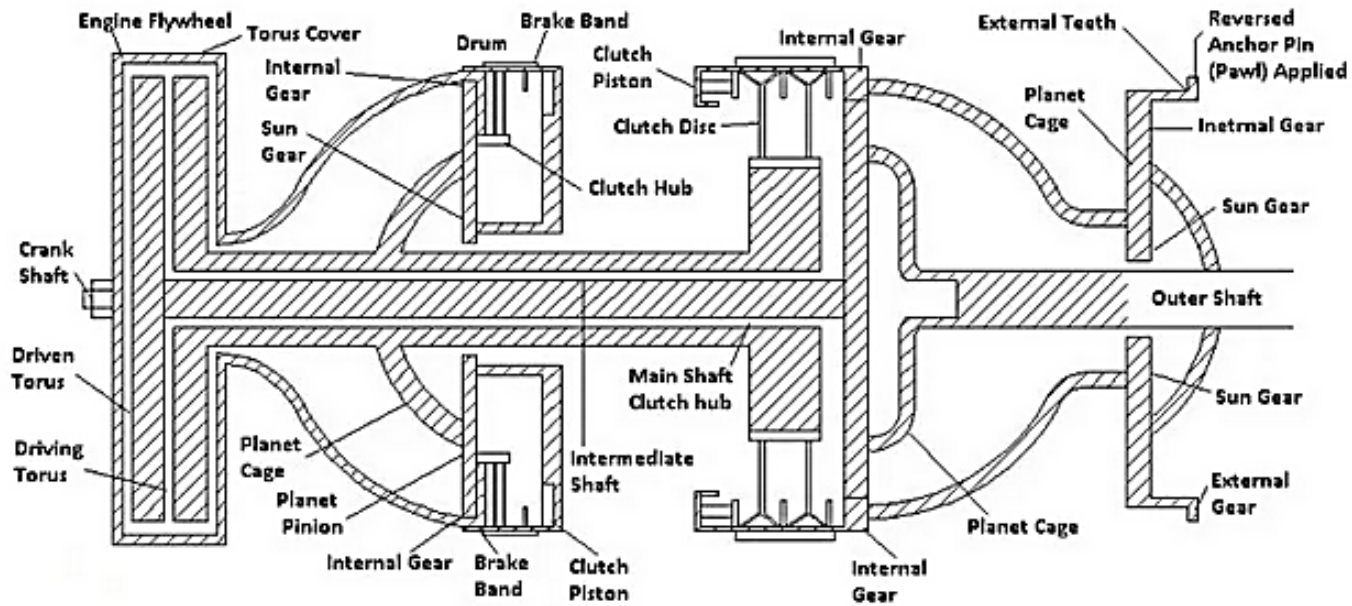

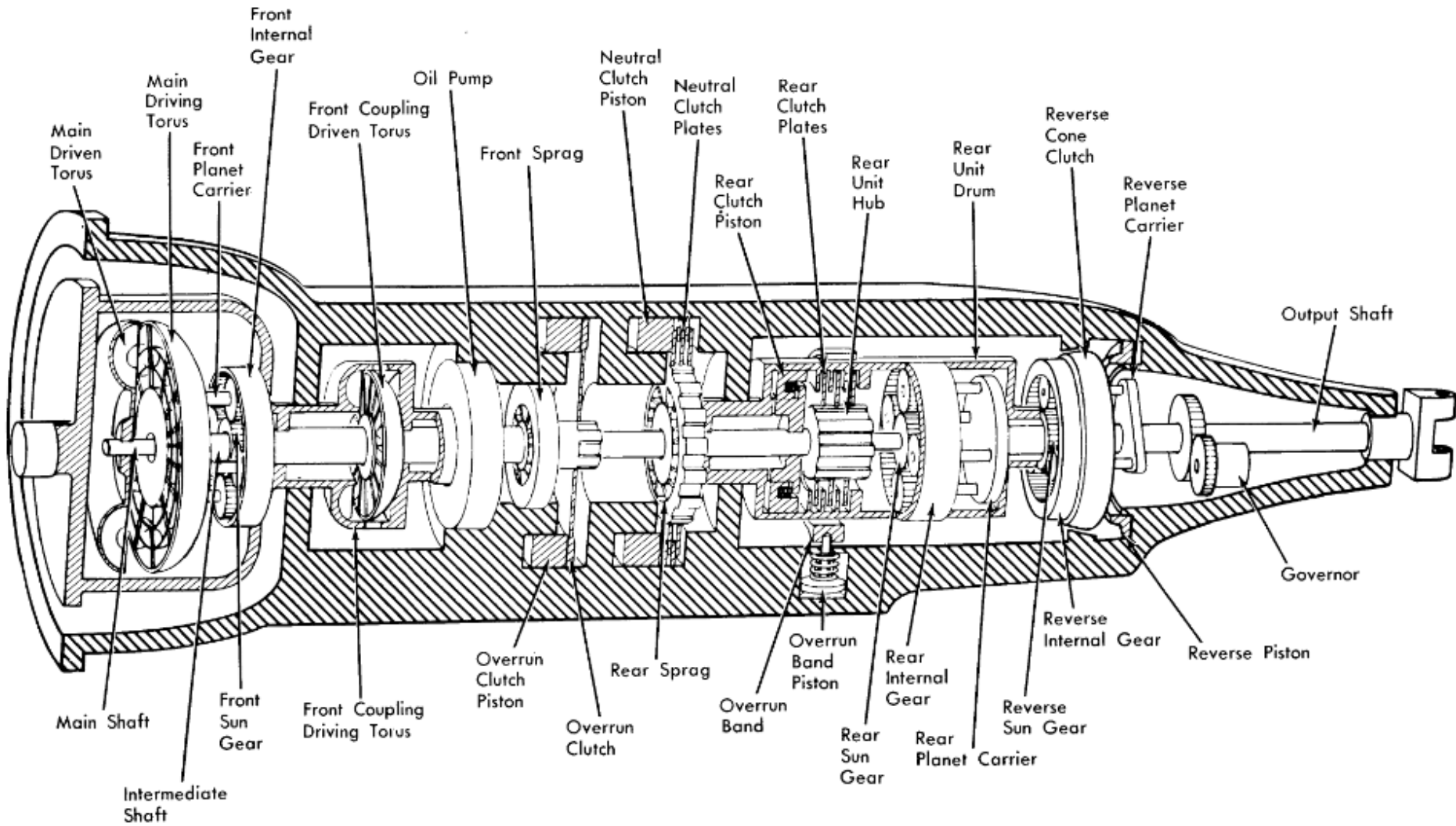



- The fluid flywheel, that is a part of the gear train, is also enclosed in this cover. The sun gear is attached to a drum around which a break band. It is placed for locking the drum and sun gear when the front unit is used for gear reduction.
- This arrangement makes the planet cage as the driven member of the front unit when the sun gear is held stationary. The planet cage is splined to a hollow intermediate shaft, whose front section connects with the driving member of the fluid flywheel, and whose rear section is splined to the clutch hob of the rear unit.
- When the planet cage receives power from the internal gear of the front unit, it transmits it forward through the intermediate shaft to the driven member.



❖ Rear unit

- In the **Rear unit**, the internal gear is fastened to a drum and break band assembly for locking it when the unit is in reduction.
- The sun gear is the driving member. It receives its power from the main shaft. The planet cage, splined to the output shaft is the driven member when the internal gear is held stationary.



❖ Reverse Unit

- The **Reverse Unit** consists of sun gear fastened to the internal gear of the rear unit. A planet cage splined to the output shaft and an internal gear. The internal gear has external as well as internal teeth and is held stationary when anchor pin engages in external teeth.
- The front and gear unit contain hydramatically operated multi-disc clutches. These are used for locking various gears together when the units are in direct drive. In the front unit, the clutch can lock the planet cage and the sun gear. In the rear unit, the clutch connects the rear section of the intermediate shaft with the internal gear when it is applied.



❖ First Gear

- To obtain first gear, both the rear and front units are placed in a reduction by the application of brake bands to both drums to hold them stationary.
- With the sun gear of the front units locked, the power is transmitted from the flywheel to the torus cover and to the planet cage, which revolves around the stationary sun gear at a reduced speed. The cage transmits power to the driving torus of the fluid flywheel through the front section of the intermediate shaft.
- From the driven torus the power is transmitted by the main shaft to the sun gear of the rear unit. The sun gear revolves the planet pinions which drive the output shaft. The combined gear ratio of the two sets of gears is the product of their gear ratios. The gear ratio in the internal gear and sun gear of the front unit have 67 and 30 teeth and those of the rear unit have 67 and 41 teeth respectively.

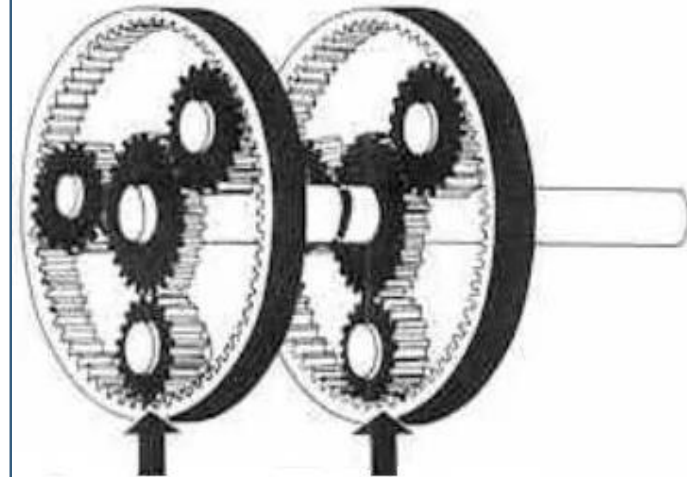

Both In Reduction



❖ Second Gear

- To obtain a second gear, the front unit is placed in direct drive by releasing the front band and applying the front clutch. Thus, the power is transmitted from the flywheel to the torus cover to the locked front unit.
- There it is transmitted directly by the front section of an intermediate shaft to the fluid flywheel. It carries back to the sun gear of the rear unit through the main shaft. The rear unit carries the power to the output shaft. The gear ratio for the second gear is 2:63:1.

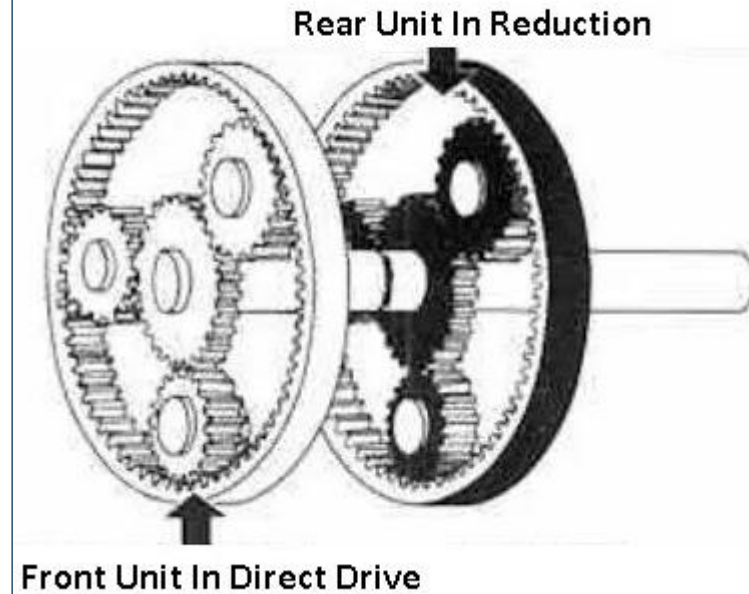



❖ Third Gear

- To obtain third gear, release the clutch and apply the band in the front unit, place it back in reduction.
- Release the band and apply the clutch in rear unit to convert it to direct drive. The power flow is from the flywheel to the front unit, rear unit and finally to the output shaft. The gear ratio for the third speed is 1:45:1.

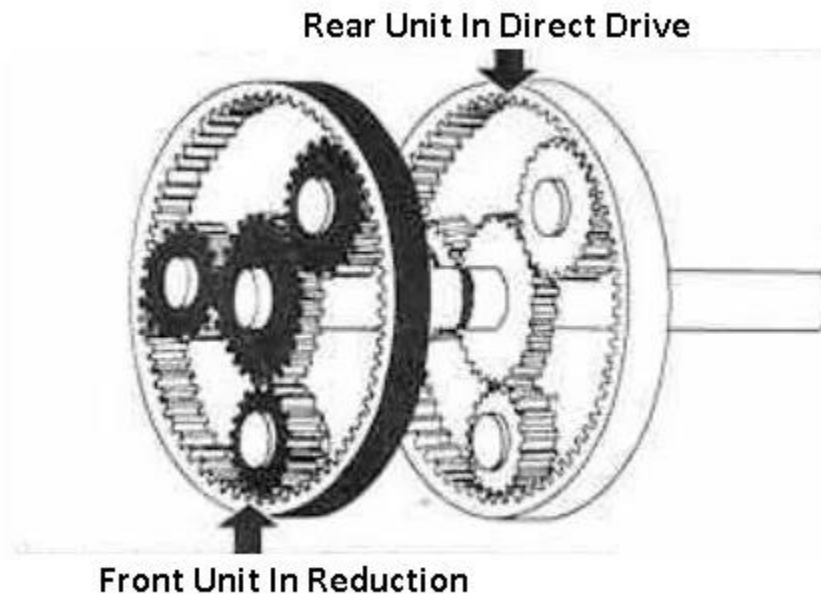



❖ Fourth Gear

- To obtain fourth gear, lock the clutch and release the band in the front unit-shifting it into direct drive-and bearing the rear unit into direct drive.
- The power flow is from the flywheel to the locked front unit, intermediate shaft, rear unit and finally to the output shaft.

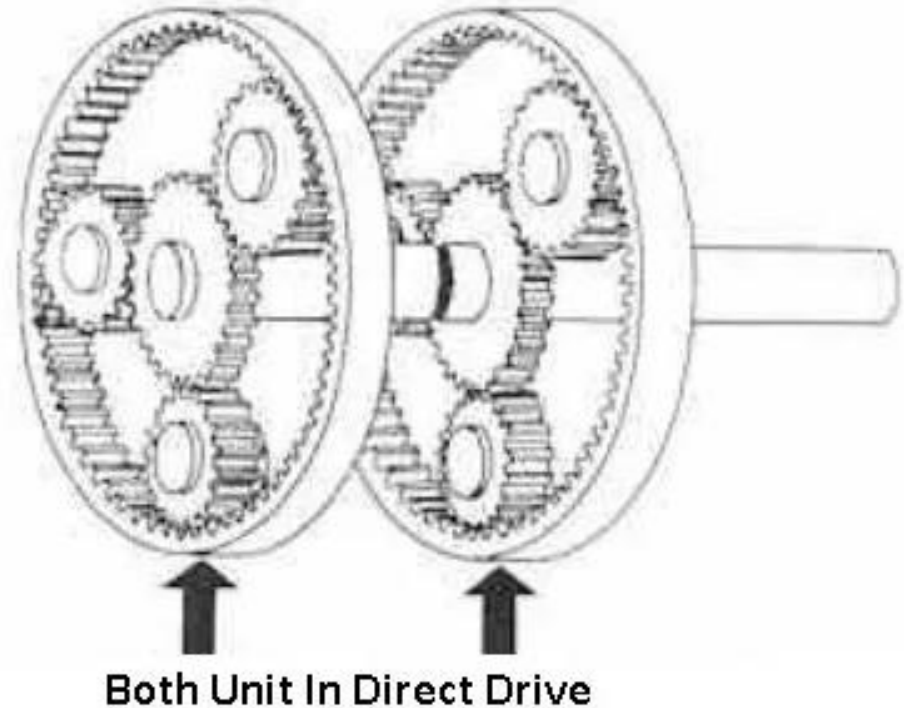



❖ Reverse Gear

- In all the forward speeds, the reverse unit turns freely and transmits no power. To obtain reverse speed, place the selector lever in the reverse position, shifting the front unit into reduction. Release the rear band and clutch, and engage the anchor pin in the external teeth of the reverse internal gear, so as to hold the gear stationary.
- The power flows from the flywheel to the torus cover, front internal gear, planet cage, intermediate shaft and to the fluid flywheel, as in the first gear. From there, it is transmitted to the rear sun gear by the main shaft. When the reverse internal gear is locked, the reverse planet cage cannot turn freely, but hold the rear planet cage to the output shaft.
- The rear unit planet cage acts here as an idler which causes the rear unit internal gear to turn in a reverse direction. The rear unit internal gear drive the reverse sun gear in a reverse direction, causing the reverse planet cage to move the output shaft in reverse. The gear ratio in reverse is 4:30:1.



❖ **Controlled-Coupling Hydramatic Transmission**

- This type of hydramatic transmission retains many features of the earlier hydramatic drive, with some major changes.
- In it, the front planetary unit occupies the space between the torus cover and the fluid coupling but is still driven by the torus cover.
- The sun gear is linked to a sprag (one-way) clutch and overrunning clutch, instead of with a band and servo, to hold it stationary.
- Another change in the front unit is the use of a liquid coupling in place of a hydraulically operated friction clutch for providing direct drive.
- The rear unit internal gear can be held by a rear sprag clutch or by a servo-operated overrunning band to shift the unit into reduction.



- The rear unit is shifted to direct drive by means of a hydraulically outer race of the rear sprag clutch and the transmission case. When it is applied, it allows the rear sprag clutch to hold the rear internal gear. When it is released, it shifts the rear unit into neutral. The gear system is similar to that used in hydramatic drive. However, the methods used to shift the gears and locations of gears differ.

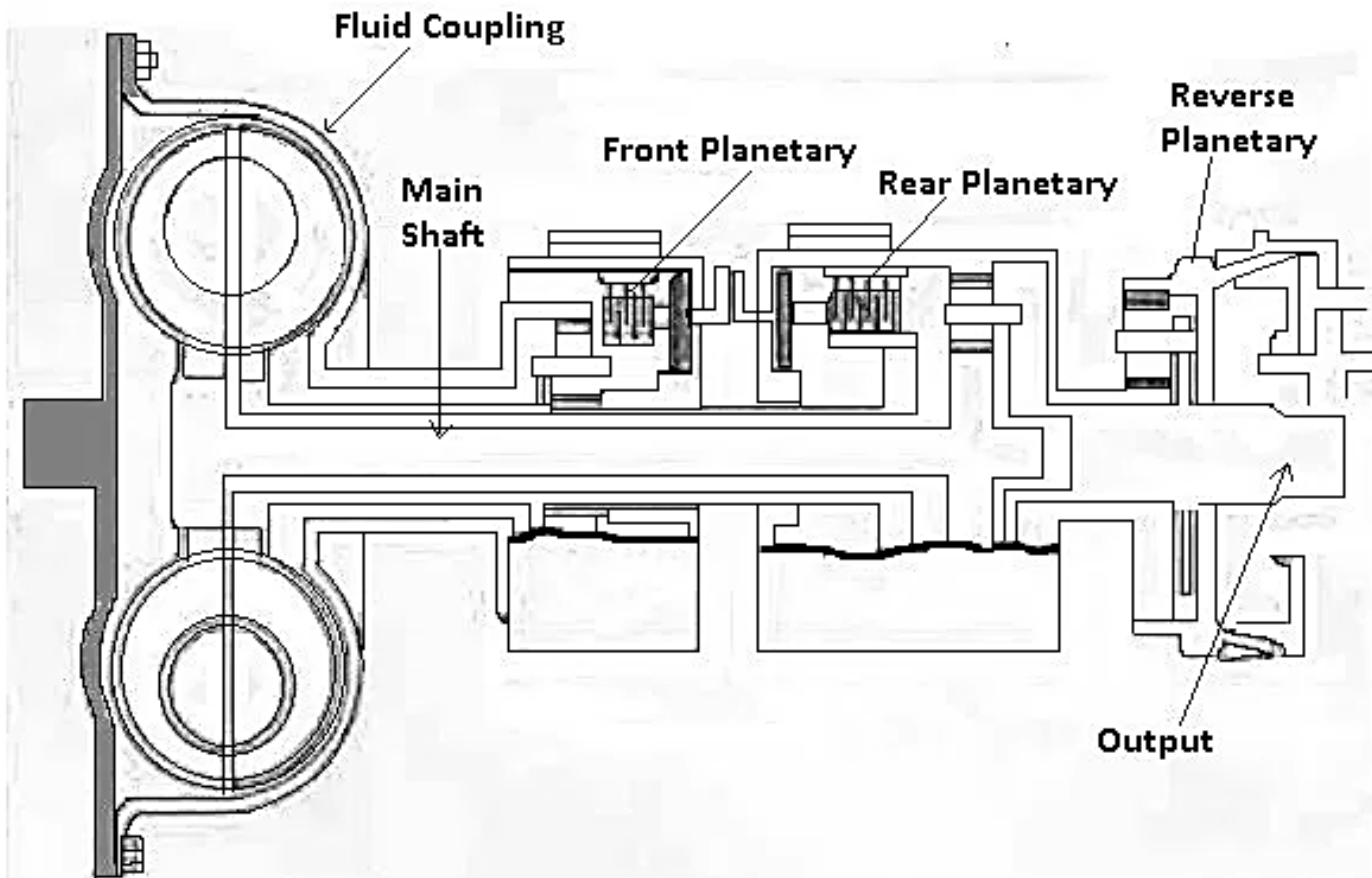



❖ **Three-Speed Hydramatic Transmission**

- This type of hydramatic transmission offers three selective forward drive ranges-knowns as drive left, drive right, and low. Reverse and park are the other two positions. The drive left the range, the transmission starts in first and shifts automatically to second and third.
 - In the drive right range, the transmission starts in first but will not shift above the second unit until a speed of 70-82 m/h is reached. In low range, the transmission remains in first gear regardless of the throttle opening or vehicle speed.
- ❖ The three-speed hydramatic transmission consists of three major unit.**
- Torque converter fluid coupling. It is composed of the drive torus, the driven torus and the torque multiplier.
 - Front planetary unit. It consists of the sun gear, internal gear, planet gear and carrier from the clutch and reverse cone clutch.
 - Rear planetary unit. It consists of a rear sun gear, planet pinions, internal gear, planet carrier, output shaft, a neutral clutch, sprag clutch and overrunning band.



❖ Advantage of Automatic Transmission

- Simple driving control.
- Improved acceleration and hill-climbing.
- Reduced fuel consumption.
- Less wear and tear due to planetary gearing.
- Less fatigue to the driver.
- No clutch pedal or gear lever.
- Smooth running under all conditions due to hydraulic coupling and automatic gear change.
- No shocks or jerky driving.
- Noiseless gear shifting.
- Longer life.



❖ The Hydraulic Control system

- The automatic transmission has to do numerous tasks. You may not realize how many different ways it operates. For instance, here are some of the features of an automatic transmission:
 - If the car is in overdrive (on a four-speed transmission), the transmission will automatically select the gear based on vehicle speed and throttle pedal position.
 - If you accelerate gently, shifts will occur at lower speeds than if you accelerate at full throttle.
 - If you floor the gas pedal, the transmission will downshift to the next lower gear.
 - If you move the shift selector to a lower gear, the transmission will downshift unless the car is going too fast for that gear. If the car is going too fast, it will wait until the car slows down and then downshift.
 - If you put the transmission in second gear, it will never downshift or upshift out of second, even from a complete stop, unless you move the shift lever.



- The components of hydraulic control systems are;
 - OIL PUMP
 - GOVERNOR
 - VALVE BODY
 - SHIFT VALVES
 - BANDS



❖ Oil Pump(Gear Pump)

- The pump is usually located in the cover of the transmission.
- It draws fluid from a sump in the bottom of the transmission and feeds it to the hydraulic system.
- It also feeds the transmission cooler and the torque converter.
- The inner gear of the pump hooks up to the housing of the torque converter, so it spins at the same speed as the engine.
- The outer gear is turned by the inner gear, and as the gears rotate, fluid is drawn up from the sump on one side of the crescent and forced out into the hydraulic system on the other side.





❖ The Governor

- The **governor** is a clever valve that tells the transmission how fast the car is going.
- It is connected to the output, so the faster the car moves, the faster the governor spins.
- Inside the governor is a spring-loaded valve that opens in proportion to how fast the governor is spinning -- the faster the governor spins, the more the valve opens. Fluid from the pump is fed to the governor through the output shaft.
- The faster the car goes, the more the governor valve opens and the higher the pressure of the fluid it lets through.

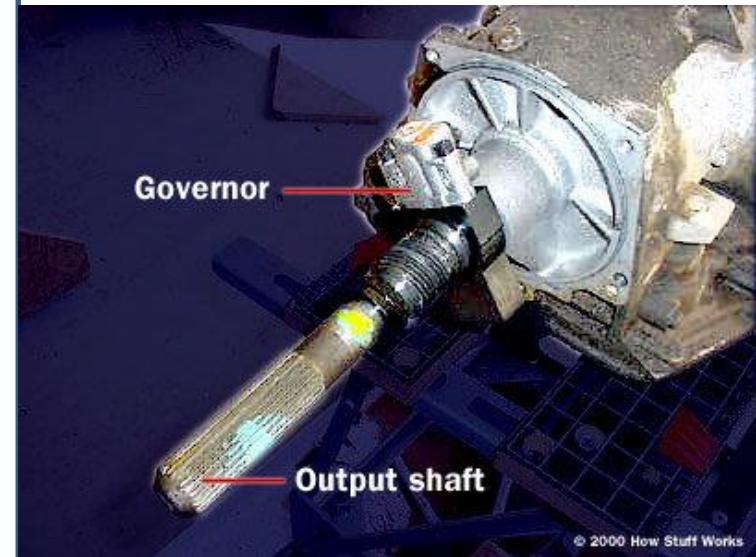



❖ Valve Body

- The brain of the automatic transmission.
- Contains a maze of channels and passages that direct hydraulic fluid to the numerous valves.
- These valves activate the appropriate clutch pack or band servo to smoothly shift to the appropriate gear for each driving situation.

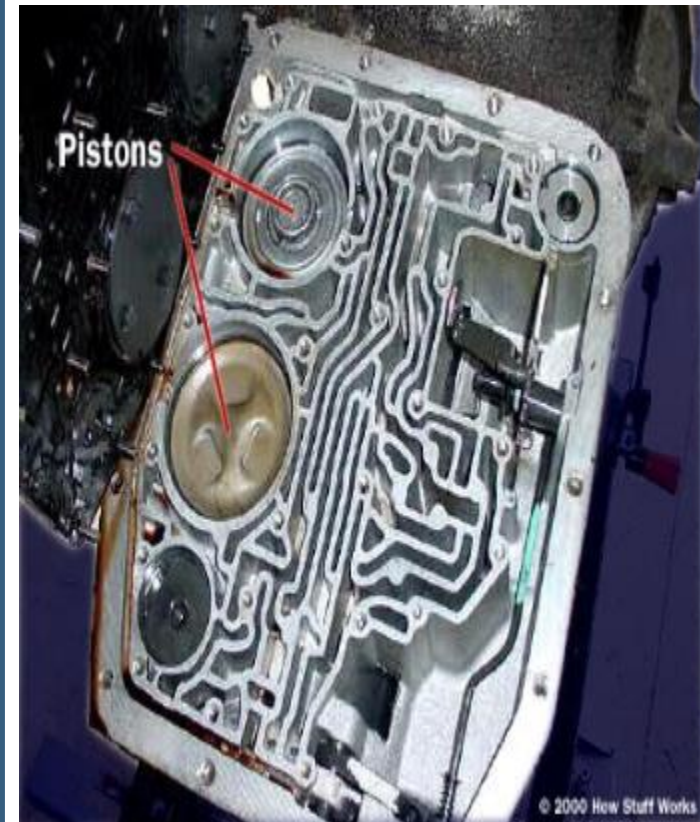



❖ Shift Valves

- **Shift valves** supply hydraulic pressure to the clutches and bands to engage each gear.
- The valve body of the transmission contains several shift valves. The shift valve determines when to shift from one gear to the next.
- For instance, the 1 to 2 shift valve determines when to shift from first to second gear. The shift valve is pressurized with fluid from the governor on one side, and the throttle valve on the other.
- They are supplied with fluid by the pump, and they route that fluid to one of two circuits to control which gear the car runs in.

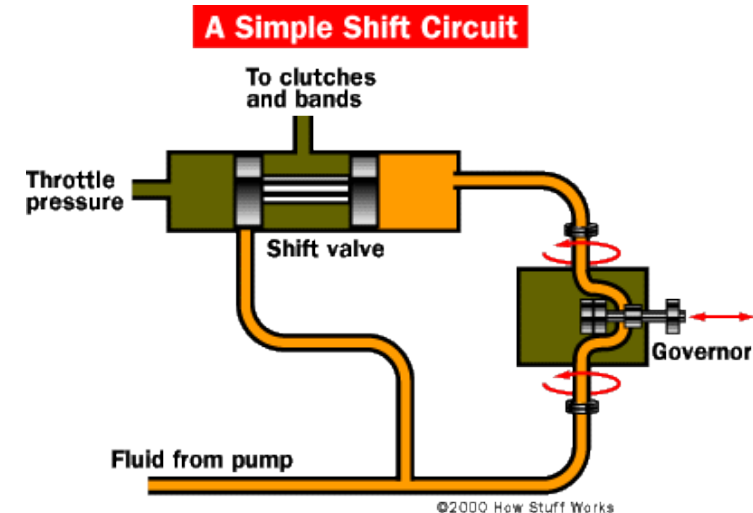



❖ Bands

- The bands in a transmission are, literally, steel bands that wrap around sections of the gear train and connect to the housing.
- They are actuated by hydraulic cylinders inside the case of the transmission.
- In the figure, you can see one of the bands in the housing of the transmission.
- The gear train is removed. The metal rod is connected to the piston, which actuates the band.

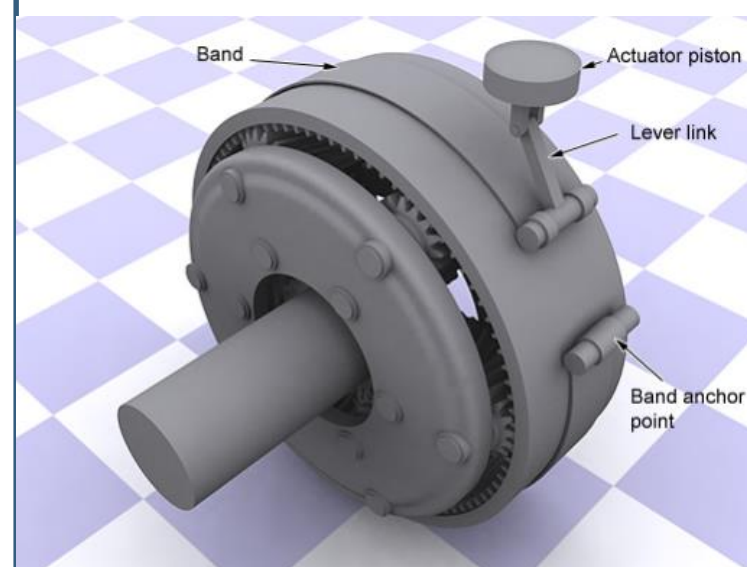

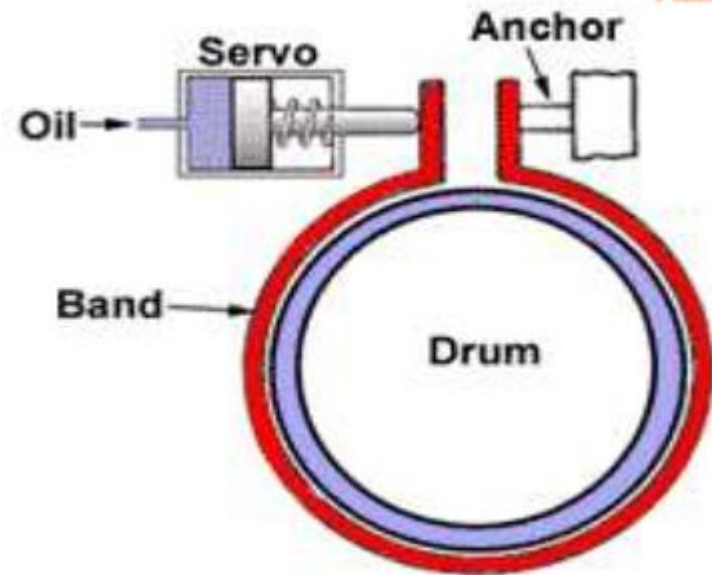



- The computer uses sensors on the engine and transmission to detect such things as throttle position, vehicle speed, engine speed, engine load, brake pedal position, etc. to control exact shift points as well as how soft or firm the shift should be. Once the computer receives this information, it then sends signals to a solenoid pack inside the transmission.
- The solenoid pack contains several electrically controlled solenoids that redirect the fluid to the appropriate clutch pack or servo in order to control shifting. Computerized transmissions even learn your driving style and constantly adapt to it so that every shift is timed precisely when you would need it.



❖ **Continuously Variable Transmission (CVT):**

- A continuously variable transmission (CVT) is a transmission which can change seamlessly through an infinite number of effective gear ratios between maximum and minimum values. This allows the motor to put out the proper amount of power improving on efficacy of traditional transmissions.
- This contrasts with other mechanical transmissions that only allow a few different distinct gear ratios to be selected.
- This can provide better fuel economy than other transmissions by enabling the engine to run at its most efficient revolutions per minute (RPM) for a range of vehicle speeds.



❖ HISTORY

- Leonardo da Vinci sketches is the basis for the first continuously variable transmission in 1490.
- First patent for the CVT Transmission was made by Daimler & Benz in 1886.
- The first workable belt driven CVT was designed and built by the **Dutchman Huub van Doorne in 1958.**
- In Early 1990's Nissan introduced CVT in their Nissan March



Working:-

- Traditional transmissions use a gear set that provides a given number of ratios (or speeds). The transmission (or the driver) shifts gears to provide the most appropriate ratio for a given situation: Lowest gears for starting out, middle gears for acceleration and passing, and higher gears for fuel-efficient cruising.
- Though there are several types of CVTs, most cars use a pair of variable-diameter pulleys, each shaped like a pair of opposing cones, with a metal belt or chain running between them. One pulley is connected to the engine (input shaft), the other to the drive wheels (output shaft).

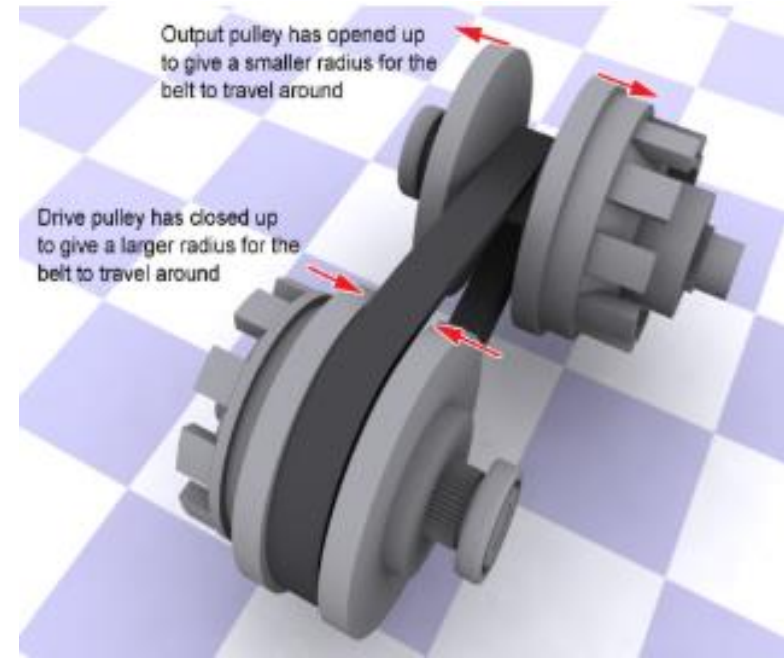



- The halves of each pulley are moveable; as the pulley halves come closer together the belt is forced to ride higher on the pulley, effectively making the pulley's diameter larger.
- Changing the diameter of the pulleys varies the transmission's ratio (the number of times the output shaft revolves for each revolution of the engine), in the same way that a 10-speed bike routes the chain over larger or smaller gears to change the ratio.
- Making the input pulley smaller and the output pulley larger gives a low ratio (a large number of engine revolutions producing a small number of output revolutions) for better low-speed acceleration.
- As the car accelerates, the pulleys vary their diameter to lower the engine speed as car speed rises.
- This is the same thing a conventional automatic or manual transmission does, but while a conventional transmission changes the ratio in stages by shifting gears, the CVT continuously varies the ratio -- hence its name.

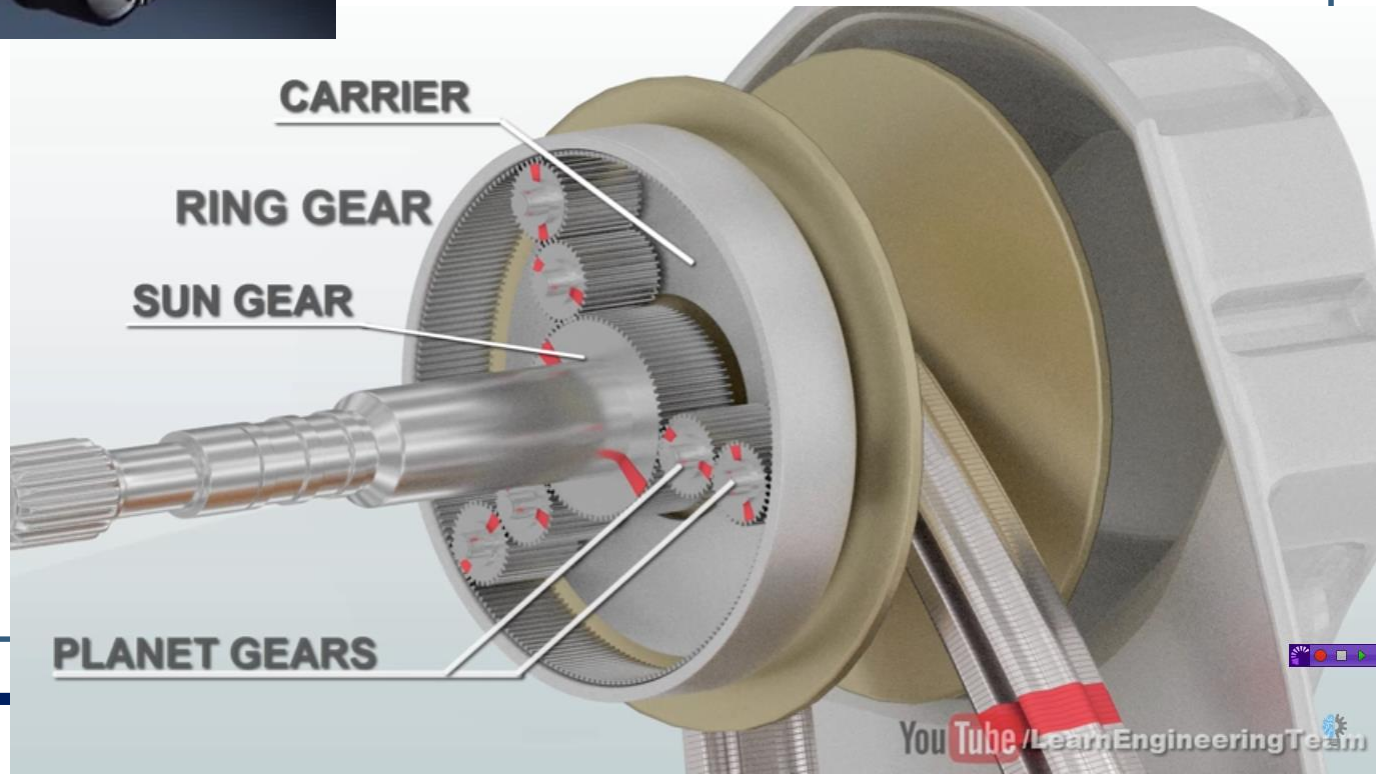



❑ COMPONENTS

- **A high-power metal or rubber belt**
- **A variable-input "driving" pulley**
- **An output "driven" pulley**
- CVTs also have various microprocessors and sensors, but the three components described above are the key elements that enable the technology to work.
- The variable-diameter pulleys are the heart of a CVT. Each pulley is made of two 20-degree cones facing each other. A belt rides in the groove between the two cones. V-belts are preferred if the belt is made of rubber.
- When the two cones of the pulley are far apart (when the diameter increases), the belt rides lower in the groove, and the radius of the belt loop going around the pulley gets smaller.



- When the cones are close together (when the diameter decreases), the belt rides higher in the groove, and the radius of the belt loop going around the pulley gets larger. CVTs may use hydraulic pressure, centrifugal force or spring tension to create the force necessary to adjust the pulley halves.
- Variable-diameter pulleys must always come in pairs. One of the pulleys, known as the drive pulley(or driving pulley), is connected to the crankshaft of the engine.
- The driving pulley is also called the input pulley because it's where the energy from the engine enters the transmission. The second pulley is called the driven pulley because the first pulley is turning it.
- As an output pulley, the driven pulley transfers energy to the driveshaft

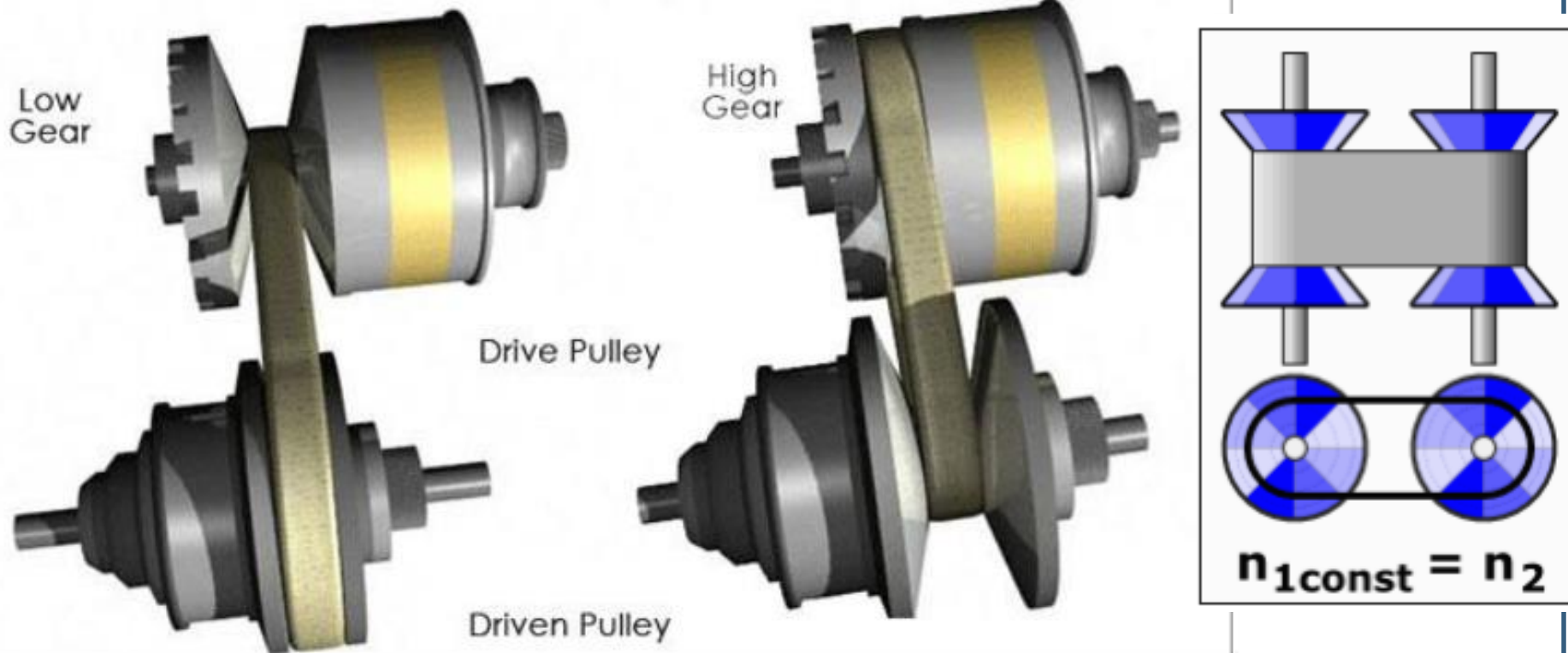

- The distance between the center of the pulleys to where the belt makes contact in the groove is known as the pitch radius. When the pulleys are far apart, the belt rides lower and the pitch radius decreases. When the pulleys are close together, the belt rides higher and the pitch radius increases.



- When one pulley increases its radius, the other decreases its radius to keep the belt tight.
- As the two pulleys change their radii relative to one another, they create an infinite number of gear ratios from low to high and everything in between.
- When the pitch radius is small on the driving pulley and large on the driven pulley, the rotational speed of the driven pulley decreases resulting in a higher gear ratio/torque multiplication.
- When the pitch radius is large on the driving pulley and small on the driven pulley, then the rotational speed of the driven pulley increases, resulting in a lower gear ratio.
- Thus, in theory, a CVT has an infinite number of "gears" that it can run through at any time, at any engine or vehicle speed.



- The simplicity and steeples nature of CVTs make them an ideal transmission for a variety of machines and devices, not just cars.
- CVTs have been used for years in power tools and drill presses. They've also been used in a variety of vehicles, including tractors, snowmobiles and motor scooters.
- In all of these applications, the transmissions have relied on high-density rubber belts, which can slip and stretch, thereby reducing their efficiency.
- The introduction of new materials makes CVTs even more reliable and efficient. One of the most important advances has been the design and development of metal belts to connect the pulleys.
- These flexible belts are composed of several (typically nine or 12) thin bands of steel that hold together high-strength, bow-tie-shaped pieces of metal.

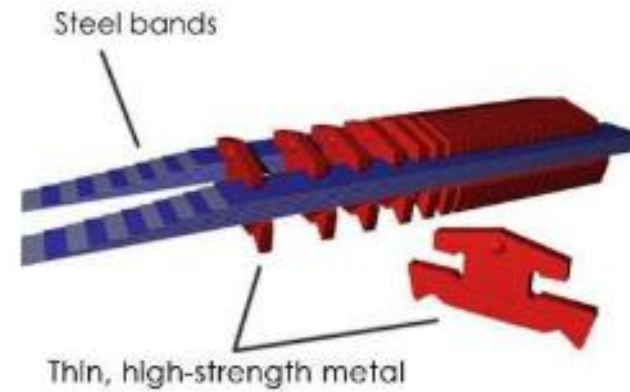

- Metal belts don't slip and are highly durable, enabling CVTs to handle more engine torque. They are also quieter than rubber-belt-driven CVTs



❖ Toroidal or roller-based CVT

- Toroidal CVTs are made up of discs and rollers that transmit power between the discs.
- The discs can be pictured as two almost conical parts, point to point, with the sides dished such that the two parts could fill the central hole of a torus. One disc is the input, and the other is the output (they do not quite touch).
- Power is transferred from one side to the other by rollers. When the roller's axis is perpendicular to the axis of the near-conical parts, it contacts the near-conical parts at same-diameter locations and thus gives a 1:1 gear ratio.



- The roller can be moved along the axis of the near-conical parts, changing angle as needed to maintain contact. This will cause the roller to contact the near-conical parts at varying and distinct diameters, giving a gear ratio of something other than 1:1.
- Systems may be partial or full toroidal. Full toroidal systems are the most efficient design while partial toroidals may still require a torque converter, and hence lose efficiency.

